

DACIA

DACIA SANDERO



23rd July 2024

1

EXPLORE YOUR SANDERO

DISCOVER



2

YOUR SANDERO FOR DAILY USE

DISCOVER



3

EQUIPMENT AND TECHNICAL CHARACTERISTICS

DISCOVER



4

THE DACIA SPIRIT: GOOD THINKING

DISCOVER



JUST
ESSENTIAL



A UNIQUE ALLY FOR THE DAY-TO-DAY

Dacia Sandero fits better than ever with your lifestyle and desires. Its lines combine robustness and dynamism in a sleek and distinctive design. Stylish, practical, modern, it offers the essential equipment and comfort to make every journey a moment of pleasure.



THE POWER OF WHAT IS ESSENTIAL

Admire the style of Dacia Sandero, a combination of robustness and dynamic lines: simply stunning. Its front and rear Y-shaped signature brand light puts the finishing touches on a strong and modern identity. Its LED dipped headlights will light up the road at night like never before.



The black radiator grille with touches of white adds to its personality. The Sandero spirit that you enjoy so much is also found in the details, such as the glossy black door mirrors, the shark fin antenna and the 16" alloy wheels.

*16" Randia alloy wheels are standard on the Journey version.



LED dipped headlights



Rear Y-shaped brand light



ALL YOU NEED IS EASILY WITHIN REACH

From the moment you step in thanks to the automatic remote opening, you feel comfortable in a welcoming and modern setting. Its panoramic dashboard combines elegance and efficiency. The driver-focused dashboard provides easy access to all the functions: intuitive heating and air-conditioning system controls, built-in 8-inch screen with navigation and smartphone replication via WIFI and USB, front and rear parking sensors, as well as height- and depth-adjustable steering wheel. The electric parking brake proves highly practical for daily use.



Keyless entry and start card



Instrument panel with digital display

[BUILD YOURS](#)

[BACK TO CONTENTS](#)

SPACIOUSNESS AND VERSATILITY

Thanks to one of the best interior spaces in its category, generous storage compartments and a spacious trunk, the Dacia Sandero adapts to your daily life. And always benefit from the latest features that allow you to drive with peace of mind.



TAKE CONTROL OF THE SPACE

Dacia Sandero perfectly adapts to your life. It has the resources with its large boot and rear folding bench seat to adapt the space to your requirements. It also comes with a lot of storage space: cup holders, door bin, closed glovebox and storage console that perfectly meet your organisational requirements.



The generous width at the shoulders for the driver and leg room for passengers in the rear provide optimum comfort. Sandero offers a decidedly warm welcome.



Boot volume: 410 litres

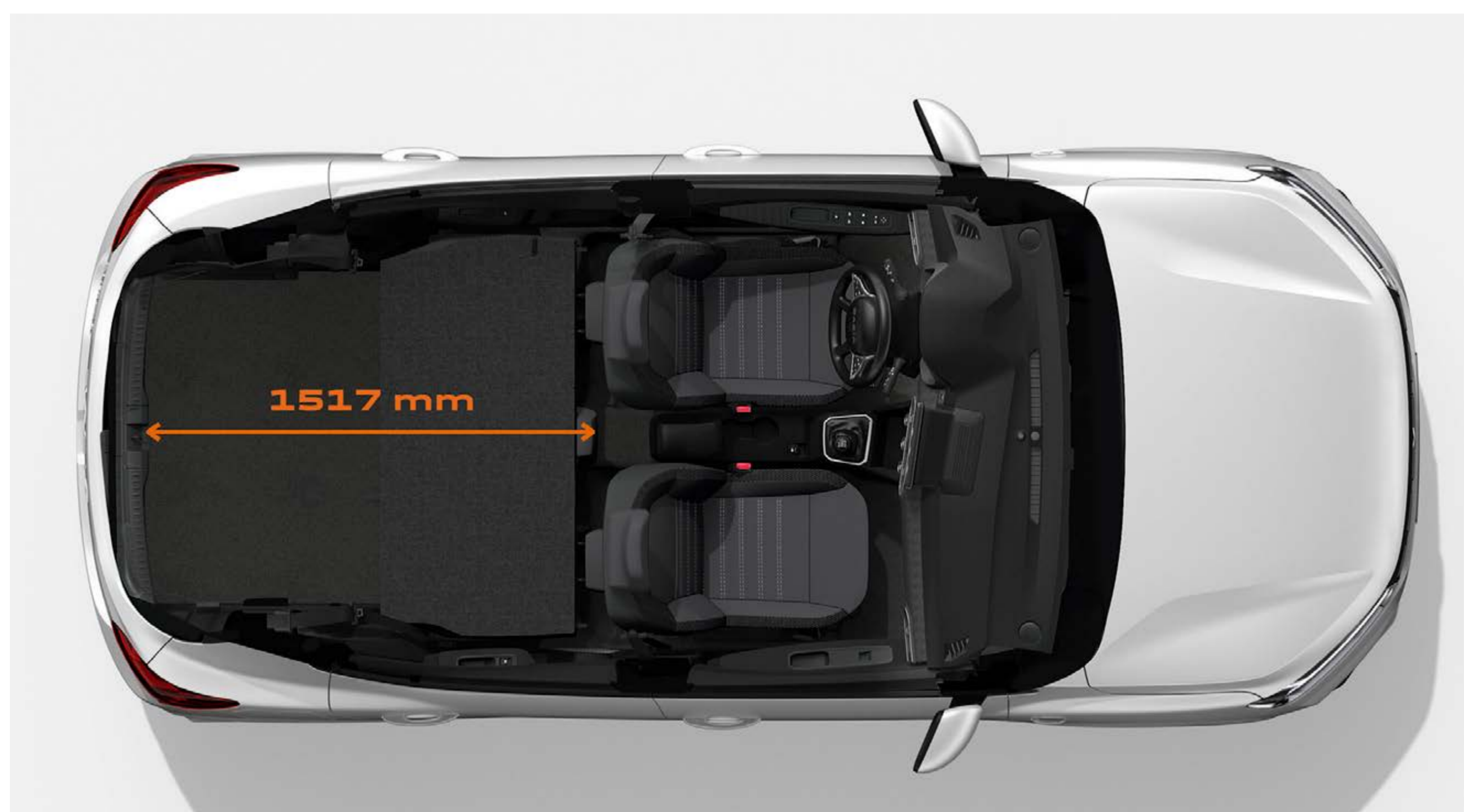

Rear bench seat folded down: boot volume of 1,108 litres



Central armrest storage: 1.2 litre**

**On Journey versions only.



CHOOSE YOUR MULTIMEDIA PREFERENCES

Dacia Sandero has three comprehensive multimedia offers, so it's up to you to choose what you want: the clever new Media Control, controlled from your smartphone and integrated into the design of the dashboard, allows you to control the radio, music, Bluetooth® connection, USB and phone.

Media Display adds voice recognition to its 8" touchscreen. Media Nav supplements its features with built-in navigation. Media Display and Media Nav are compatible with Android Auto™ and Apple CarPlay™ smartphone mirroring. The latter is available wired on Media Display and with Wi-Fi on Media Nav. You can also enjoy enhanced sound with six speakers located throughout the cabin, available on Media Nav.

Android Auto™ is a Google Inc. brand.
Apple CarPlay™ is an Apple Inc. brand.



New Media Control



Media Display

SAFETY ALL THE TIME

At Dacia, safety has always been at the heart of our concerns. Built on the latest platform designed for our vehicles, Dacia Sandero has a reinforced body structure and new-generation assistance systems. Thanks to the My Safety button, you can deactivate some of these aids at each start-up as well as when the vehicle is running. With Dacia, drive with peace of mind.

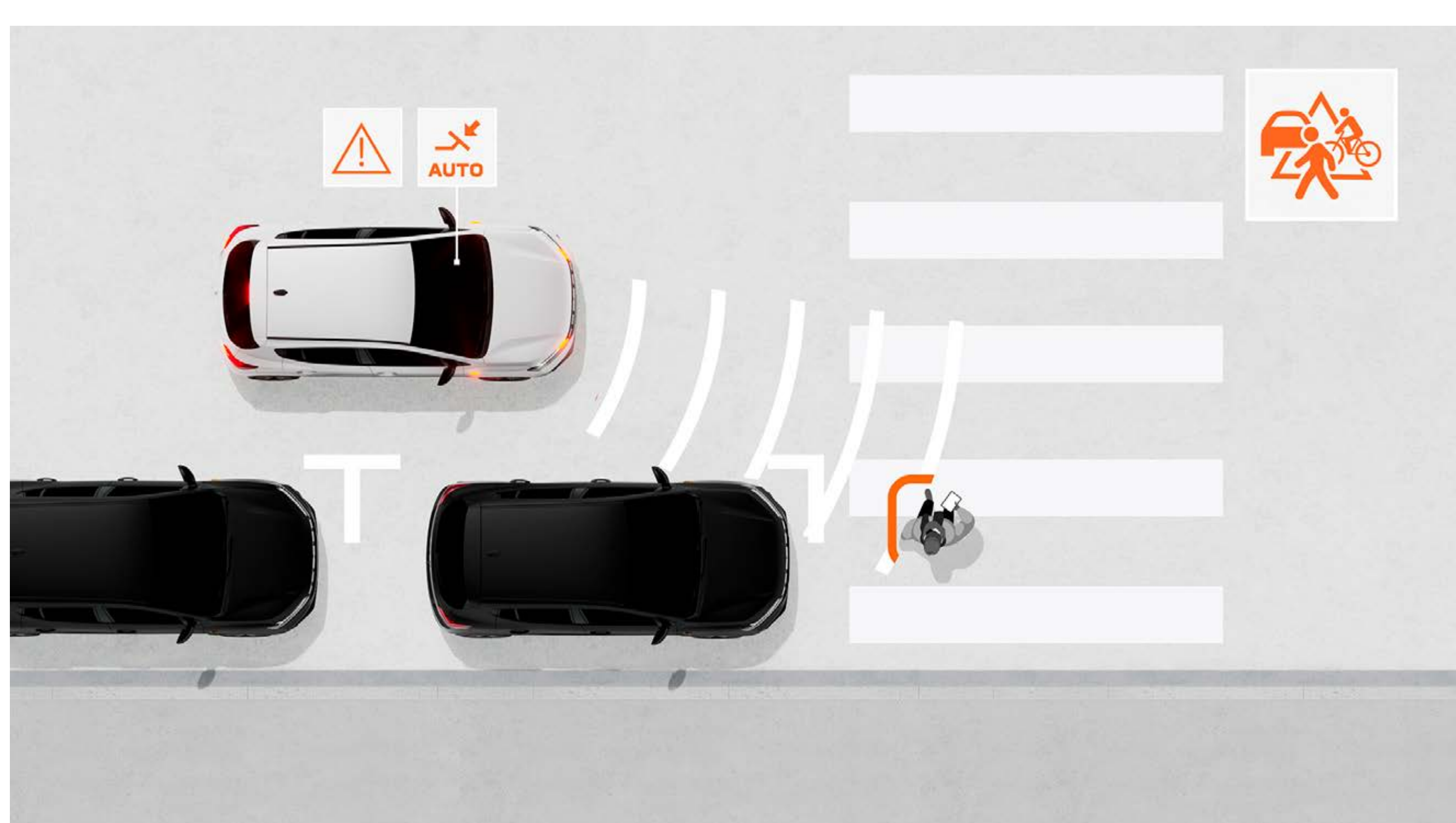

AUTOMATIC EMERGENCY BRAKING WITH PEDESTRIAN/CYCLIST DETECTION

This system prevents the risk of frontal collisions involving other vehicles, pedestrians or cyclists straight ahead and at junctions. It alerts the driver and can automatically brake the vehicle if necessary.

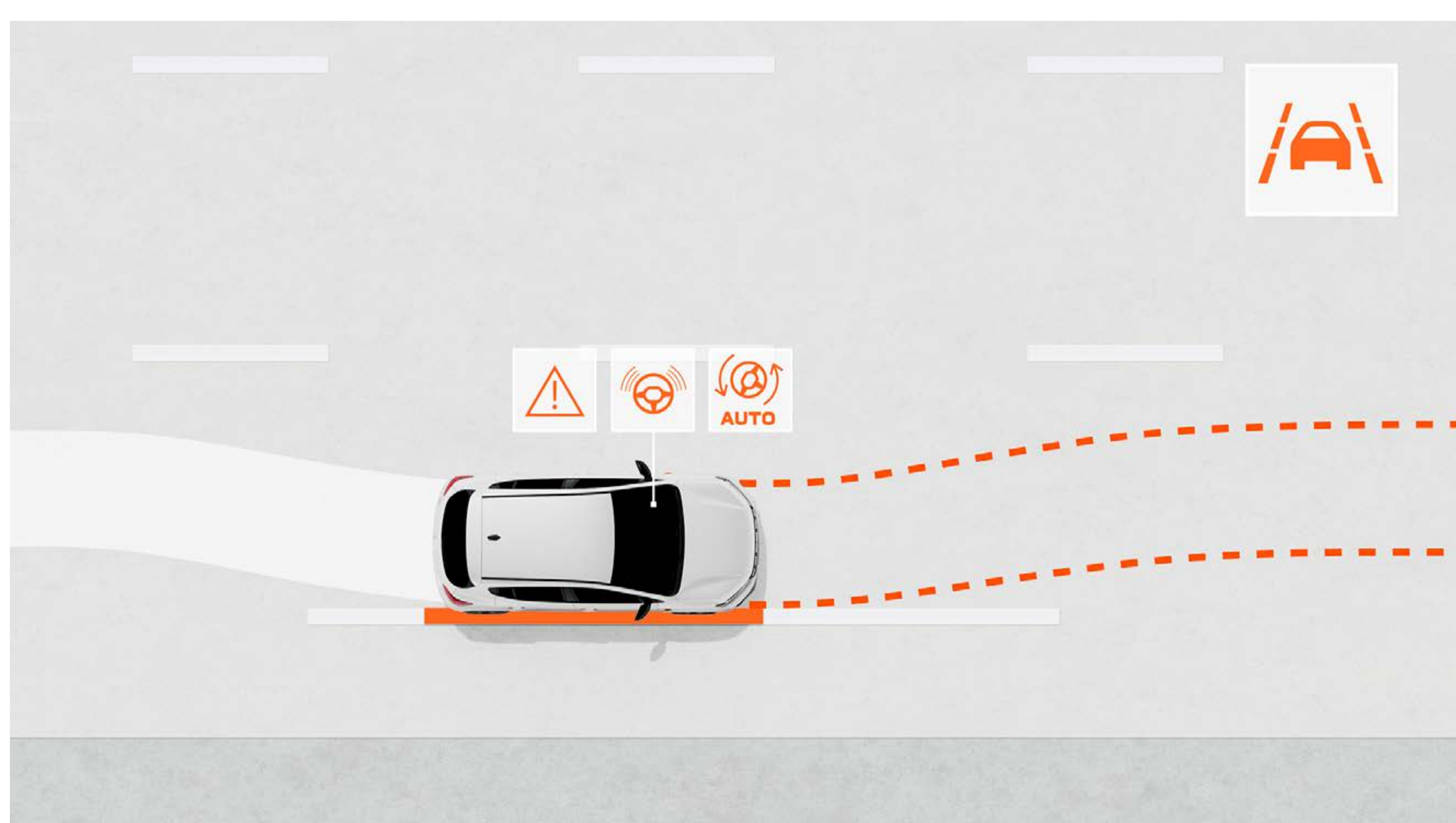

LANE KEEPING ASSIST

This assistance system monitors the vehicle's path in its lane and corrects it if necessary by automatically steering it.



DRIVER FATIGUE DETECTION SYSTEM

This helps warn the driver if fatigue is detected by analysing several parameters – including movements of the steering wheel – to encourage them to take a break.

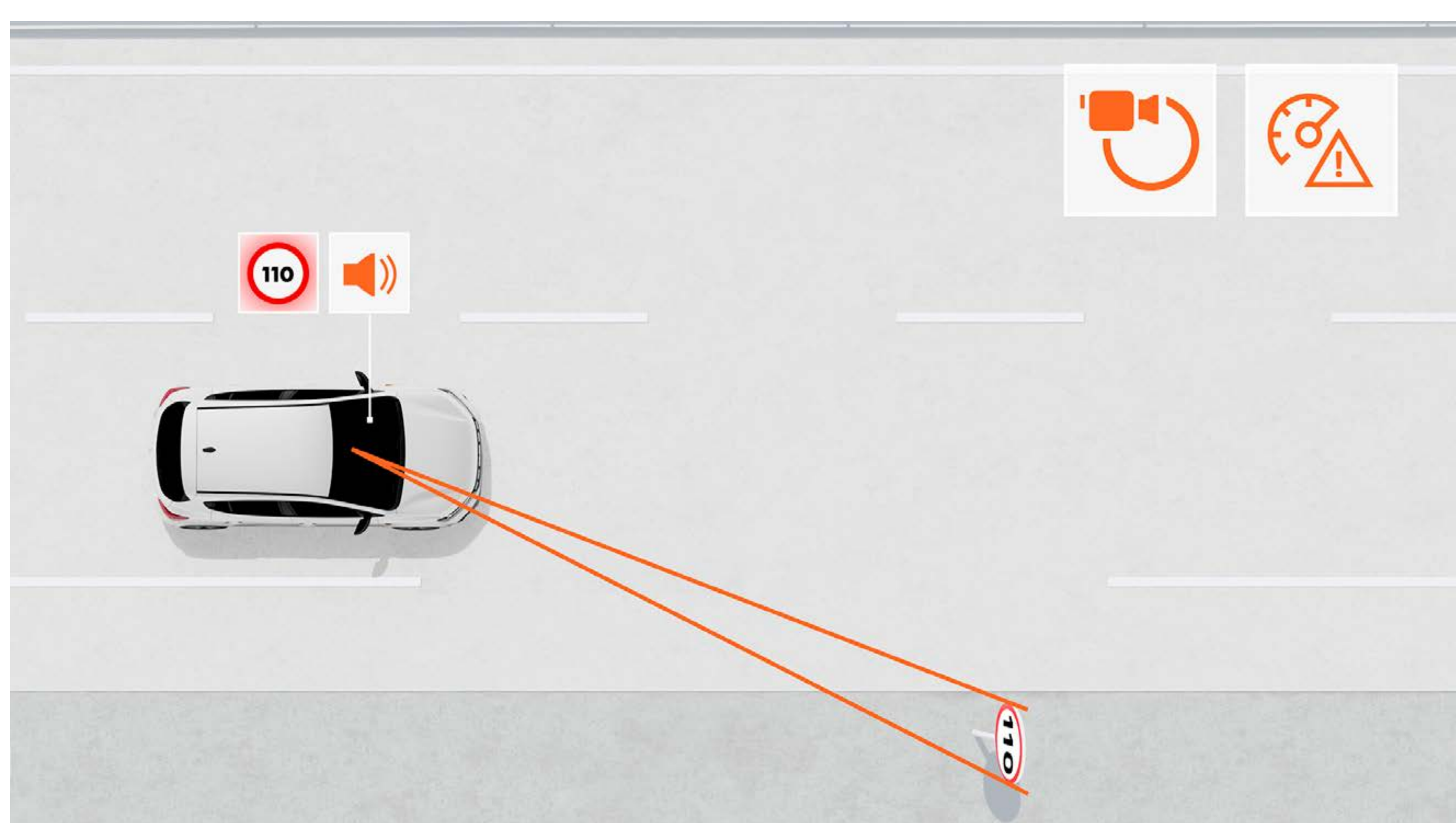

TRAFFIC SIGN RECOGNITION WITH SPEED ALERT / INTELLIGENT SPEED ASSIST

This system provides a reliable real-time indication of the maximum speed on the road and warns the driver if they exceed the speed limit with visual and audible alerts (which can be disabled).

[BUILD YOURS](#)

[BACK TO CONTENTS](#)

DISCOVER THE EQUIPMENT

COLOUR PALETTE



HUBCAPS & RIMS



INTERIOR TRIMS



ACCESSORIES



ENGINES



EQUIPMENT & OPTIONS



PRICING



SERVICING



DIMENSIONS



COLOUR PALETTE



GLACIER WHITE BLACK PEARL SHADOW GREY IRON BLUE



URBAN GREY CEDAR GREEN



GLACIER WHITE⁽¹⁾



PEARL BLACK⁽²⁾



SHADOW GREY⁽²⁾



IRON BLUE⁽²⁾



URBAN GREY⁽¹⁾



CEDAR GREEN⁽²⁾

(1) Opaque paint.
(2) Metallic paint.
Non-binding photos.

COLOUR AVAILABILITY

SOLID PAINT

	Essential	Expression	Journey
369 Glacier White	○	○	○

METALLIC PAINT

676 Pearl Black	○	○	○
KQG Shadow Grey	-	○	○
DQK Cedar Green	-	○	○
RQH Iron Blue	-	○	○

SPECIAL PAINT (PRICED AS METALLIC)

KPW Urban Grey	○	○	○
----------------	---	---	---

○ = Optional. - = Not available.

HUBCAPS AND WHEELS



15" STEEL WHEELS WITH ELMA HUBCAPS



16" ATARA FLEXWHEELS



16" RANDIA ALLOY WHEELS

INTERIOR TRIMS

ESSENTIAL

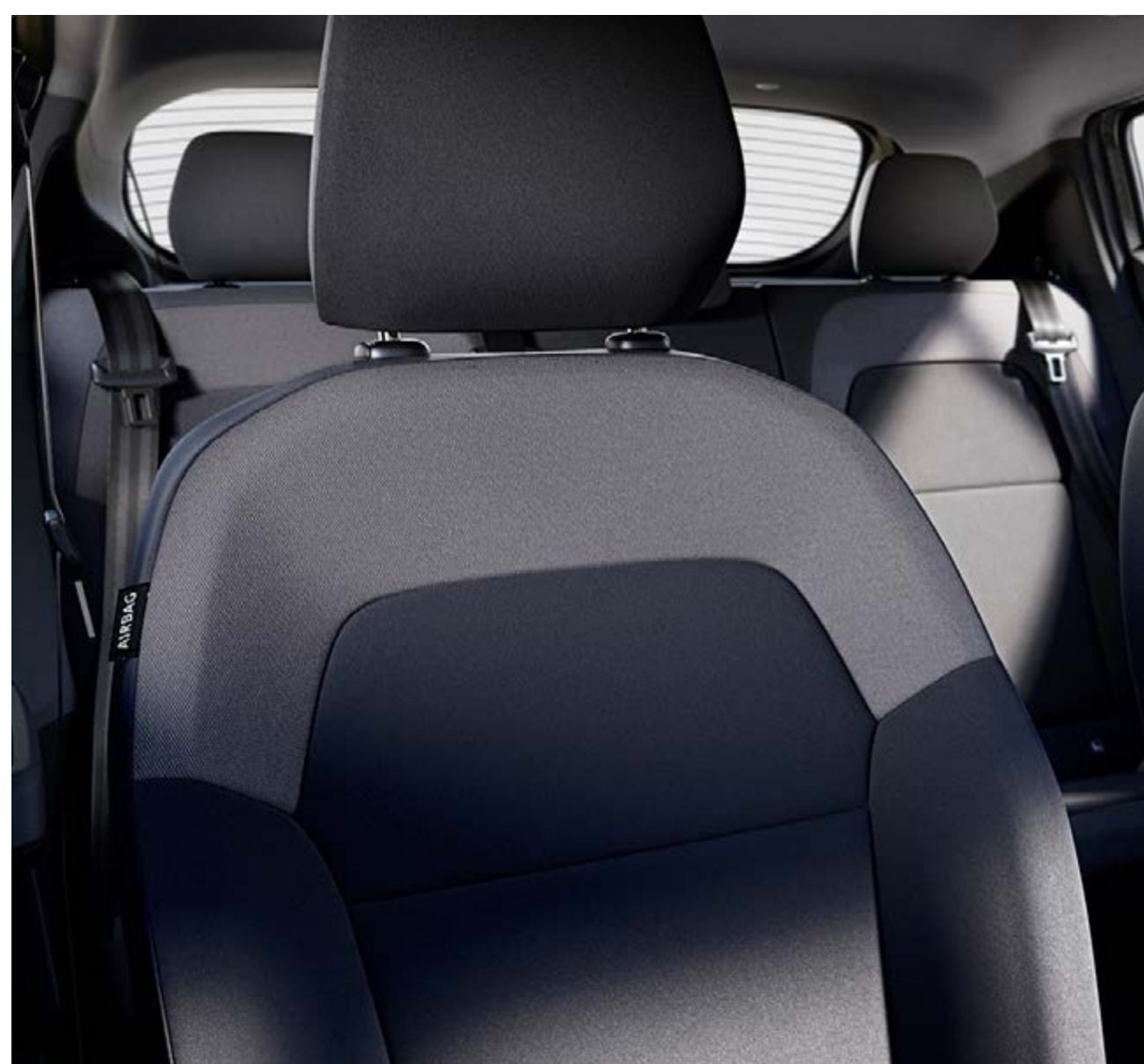

MAIN EQUIPMENT

EXTERNAL APPEARANCE

- Black grille with Dacia logo and white decorative inserts
- LED signature lighting
- Automatic daytime LED running lights
- Body-coloured front/rear bumpers
- Black exterior door handles
- Black door mirrors
- 15" Steel wheels with Elma hubcaps

INTERIOR APPEARANCE

- Fog Grey airvent surrounds and white sliders
- Titanium Black door panels
- Black interior door handles
- Split-fold rear bench 1/3 & 2/3
- Special Essential upholstery

ACTIVE AND PASSIVE SAFETY

- My Safety button to manage driver assistance systems
- Anti-locking braking system (ABS) + Emergency Brake Assist (EBA)
- Automatic emergency suburban braking with pedestrian/cyclist detection
- Electronic Stability Control (ESC) with Hill Start Assist (HSA)
- Emergency call (E-call)
- Event (accident) data logger
- Alcohol immobiliser predisposition
- traffic sign recognition with speed alert/Intelligent Speed Assist (ISA)
- Lane Departure Warning
- Lane keeping assist
- Driver fatigue detection system
- Front / rear "Rescue Code®" QR Code
- Driver's front airbag / passenger's side airbag, can be deactivated
- Shoulder and curtain side airbags
- Rear parking sensors
- Tyre pressure detection

- Tyre inflation kit
- Isofix mounts for child seats in both side rear seats

DRIVING AND CONTROLS

- Rain and light sensors
- Power assisted steering
- Stop & Start
- On-board computer: distance travelled, average speed, range, average consumption (including LPG)
- Speed limiter / cruise control

VISIBILITY

- Door mirrors with interior manual adjustment

COMFORT

- Electric door locking with radio frequency remote control
- Automatic locking of doors when in motion
- Front electric driver and passenger windows
- Height-adjustable steering wheel
- Front ceiling light
- 1 front 12 V socket
- Manual air conditioning

MULTIMEDIA & AUDIO

- New Media Control: DAB radio with steering wheel controls, jack socket and 2 speakers, Bluetooth® telephone system with satellite controls on the steering wheel, fixed smartphone holder on the dashboard, new application for Dacia Media Control smartphone

OPTIONS

- Spare wheel + jack (excluding Bi-Fuel versions)
- Metallic paint

EXPRESSION



MAIN EQUIPMENT EXPRESSION = ESSENTIAL+

EXTERNAL APPEARANCE

- Body-coloured door mirrors
- Body-coloured exterior door handles
- 16" Atara flexwheels

INTERIOR APPEARANCE

- Steel grey interior door handles
- Fabric upholstery on the dashboard and front door armrests
- Special Expression upholstery
- Height- and depth-adjustable soft feel steering wheel

ACTIVE AND PASSIVE SAFETY

- Rear parking sensors with reversing camera

VISIBILITY

- Front fog lights
- Electrically adjustable door mirrors
- Automatic wipers

COMFORT

- 4 electric windows with driver's side one-touch function
- Front ceiling light
- Keyless entry

MULTIMEDIA & AUDIO

- Media Display: multimedia system with 8" touchscreen, DAB digital radio, smartphone mirroring via USB cable, Bluetooth® connection, satellite controls on steering wheel, 4 speakers and 1 USB-A socket

OPTIONS

- Metallic paint
- Spare wheels excluding Bi-Fuel versions

JOURNEY



MAIN EQUIPMENT JOURNEY = EXPRESSION+

EXTERNAL APPEARANCE

- 16" Randia alloy wheels
- Black door mirrors
- Shark fin antenna

INTERIOR APPEARANCE

- Door sill protection
- Floor mats

DRIVING AND CONTROLS

- Front and rear parking sensors with reversing camera
- Blind spot warning
- Electronic parking brake

COMFORT

- Automatic heating and air conditioning system
- Modular boot with twin-level floor
- High central armrest with console storage

MULTIMEDIA & AUDIO

- Removable telephone holder
- 8" MediaNav with DAB Radio + Smartphone replication + Bluetooth + 6 Speakers with Apple CarPlay and Android Auto +USB-C Plug (Rear)

OPTIONS

- Metallic paint
- Spare wheels excluding Bi-Fuel versions

[BUILD YOURS](#)

[BACK TO CONTENTS](#)

ACCESSORY PACKS

STYLE PACK (ESSENTIAL & EXPRESSION)

£375 inc. fitting



Roof spoiler



Shark fin aerial



Illuminated door sills

PROTECTION PACK

£285 inc. fitting



Front & rear lower door protectors



Front & rear mud guards



Boot mat

STORAGE PACK

£122



Magnetic phone holder

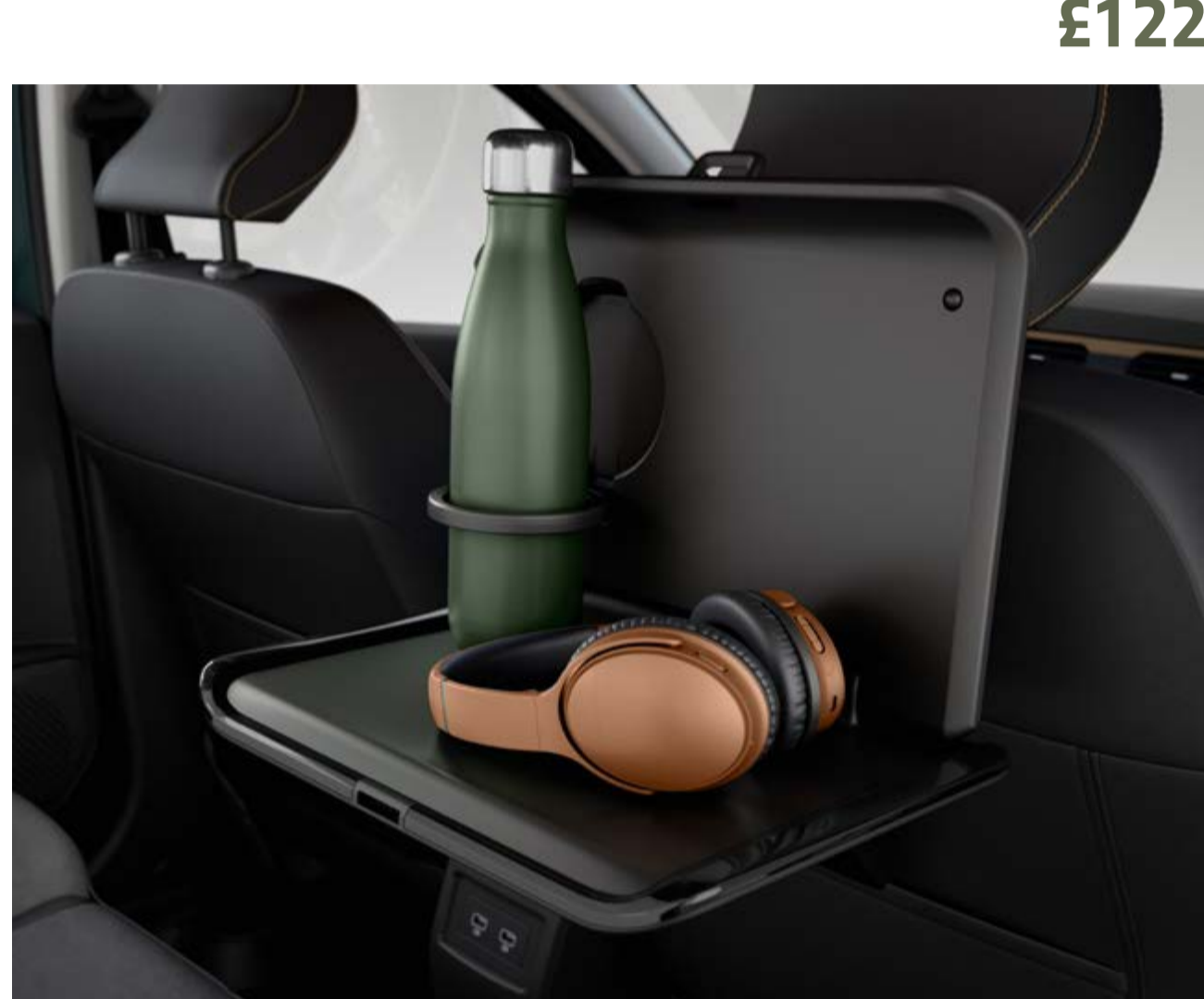

Rear tray table & fixings

Storage pack + available with 2 x rear tray tables & fixings £224

TOURING PACK

£459



Roof bars



Roof box 400L

DASH CAM PACK

£329 inc. fitting



Front and rear dashcam

CYCLE PACK

£430



Roof bars



2 x bike carriers for roof

TOW BARS



Swan neck towbar 13 pin

Removable towbar 13 pin

£579 inc. fitting

£687 inc. fitting

PREMIUM DELIVERY PACKS

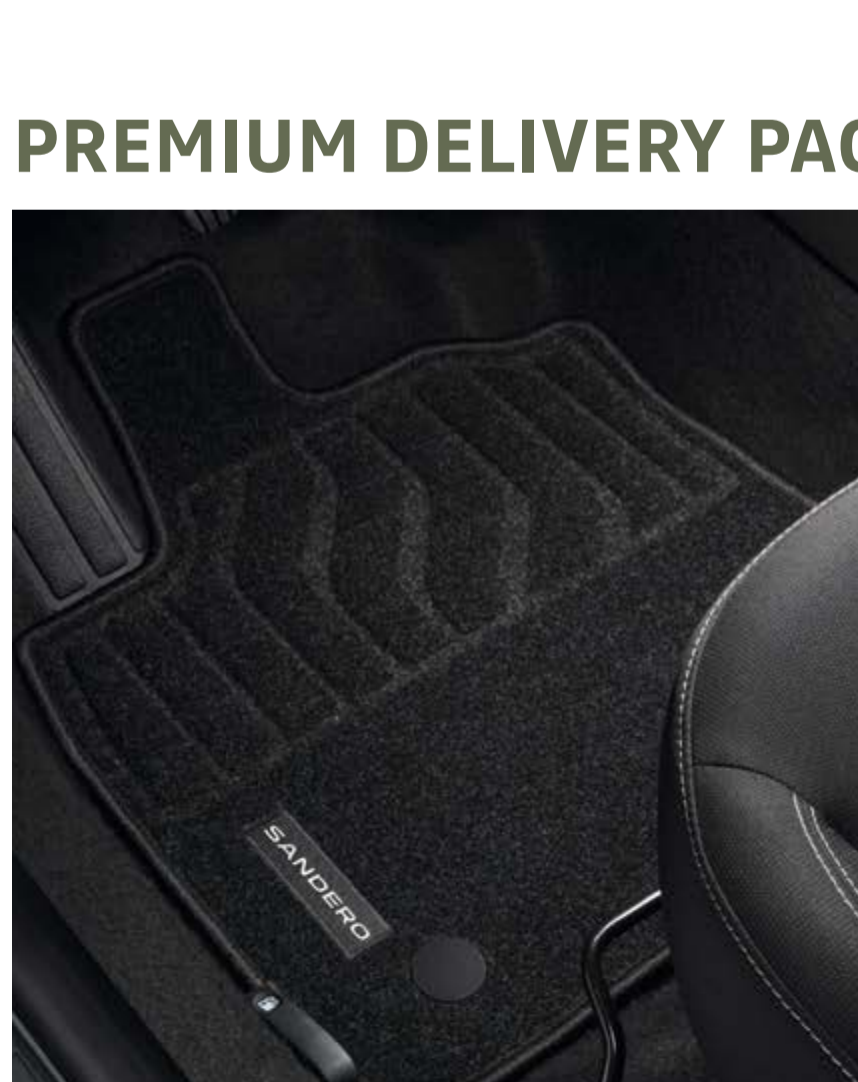

Premium mats



Safety kit

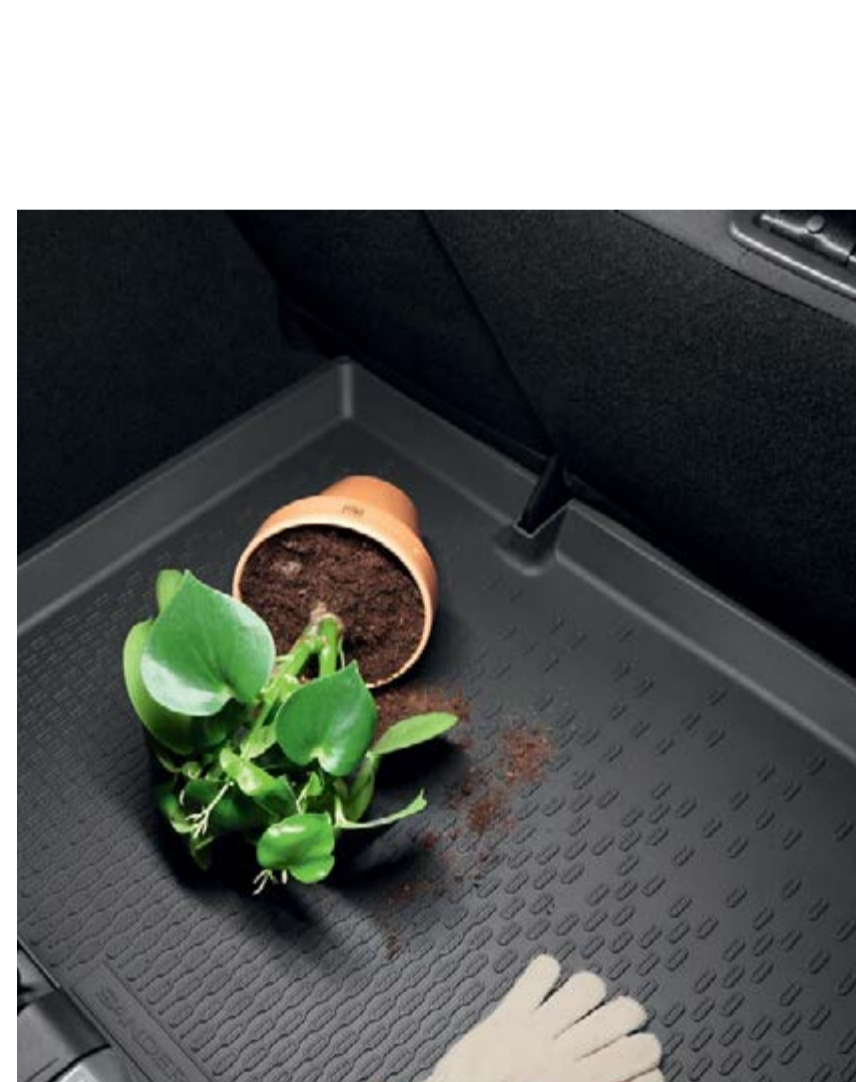

Rubber boot mat

PREMIUM DELIVERY PACK

£95

Premium mats

Safety kit

PREMIUM DELIVERY PACK+

£160

Premium mats

Safety kit

Rubber boot mat

SPARE WHEEL KIT

£290

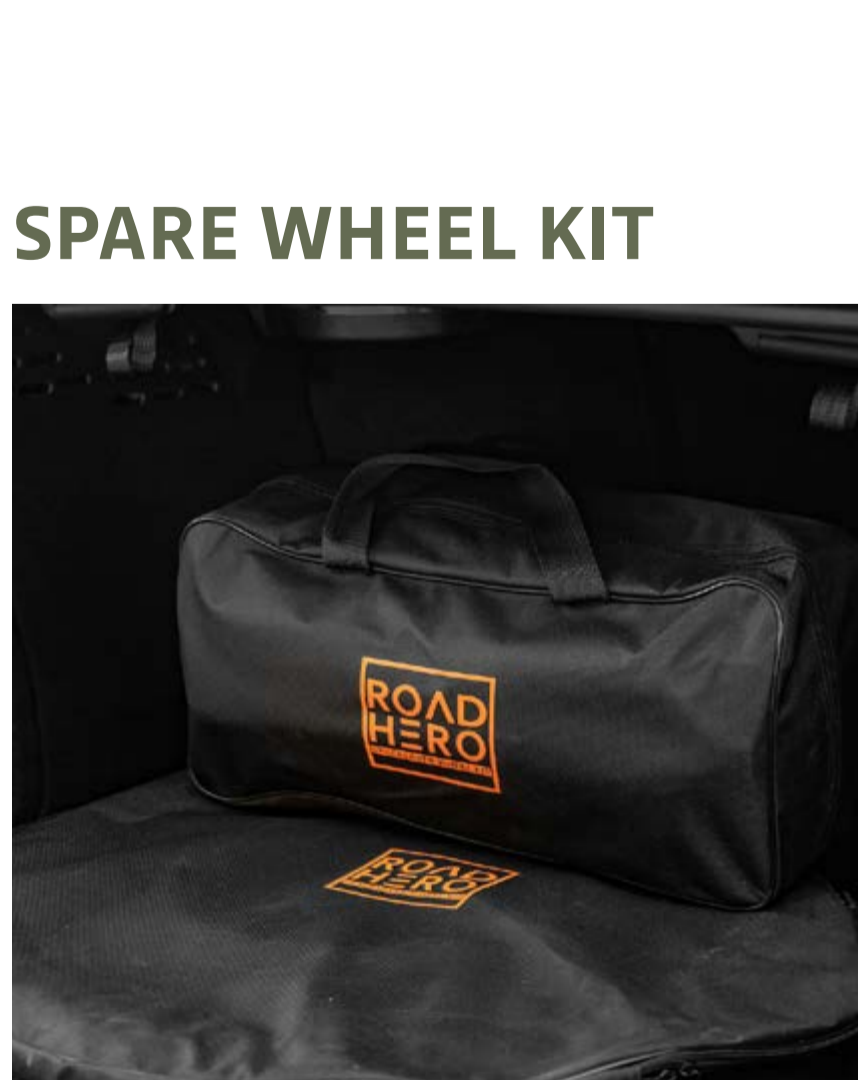

All accessories purchased prior to vehicle registration come with a 3 year manufacturers warranty
Accessories are fitted post production and may have an impact on WLTP fuel (actual) consumption and CO₂ figures

[DOWNLOAD THE ACCESSORIES BROCHURE](#)

ENGINES

	TCe 90	TCe 90 CVT	TCe 100 Bi-Fuel
SANDERO ENGINES			
Fiscal rating (CV) (France)	5	5	5
Fuel	Unleaded fuel (E10)	Unleaded fuel (E10)	Unleaded fuel (E10)/LPG
Max. power kW EEC (hp) at engine speed of (rpm)	67 at 4,600-5,000	67 at 4,500-5,000	LPG mode: 74 at 4,600-5,000 Petrol Mode: 67 at 4,800-5,000
Max. torque Nm CEE (m.kg) at an engine speed of (rpm)	160 at 2,100-3,750	142 at 1,750-3,750	LPG mode: 170 at 2,000-3,500 Petrol Mode: 160 at 2,100-3,750
Gearbox type	Manual 5-speed	Auto-CVT	Manual 5-speed
Injection type	Turbo Indirect injection	Turbo Indirect injection	Turbo Indirect injection
Capacity (cm ³)		999	
Number of cylinders/valves		3/12	
Emission control standard		Euro 6 DFull	

CHASSIS AND STEERING

Tyre dimensions	185/65 R15 88H - 195/55 R16 87H		
Steering - Turning circle, kerb to kerb (m)	10.53		
Front suspension	Pseudo McPherson with lower wishbone, spiral spring suspension with telescopic hydraulic shock absorbers and anti-roll bar		
Rear suspension	Semi-rigid axle with anti-roll bar spring suspension and telescopic hydraulic shock absorbers		

PERFORMANCE

			LPG	Petrol
Maximum speed (mph)	108	105	108	108
0-62 mph (s)	12.2	13.4	12.2	
Mid-range acceleration: 50 mph-75 mph (s)	in 4 th 5 th	11.6 20.1	12 19.1	12 20.2

FUEL CONSUMPTION AND EMISSIONS⁽¹⁾

Approval protocol	WLTP ⁽²⁾			
Fuel tank capacity fuel (l)	50	50	Petrol: 50 LPG: 40	
			LPG	Petrol
CO ₂ (g/km) Emissions Best Case - Worst Case	119/120	129	105/106	122/122
Fuel consumption during combined cycle (mpg) Best Case - Worst Case	53.3	49.6	43.5	52.3

VOLUMES AND WEIGHTS

	Essential	Expression/ Journey	Journey	Essential	Expression/ Journey
Minimum kerb weight	1,048	1,072	1098	1,103	1,128
Maximum kerb weight	1,096	1,120	1,136	1,134	1,160
Gross train weight (GTW)	2,635	2,665	1,590	2,680	2,705
Maximum permissible laden weight (MPLW)	1,535	1,565	2,690	1,580	1,605
Max. braked towing weight	1,100	1,100	1,100	1,100	1,100

(1) Official consumption and emissions according to applicable regulations. (2) WLTP (Worldwide Harmonised Light Vehicle Test Procedures): this new protocol provides results much closer to those found in daily use compared to the NEDC protocol. Fuel consumption and CO₂ emissions are certified using a standard, regulatory method. This method is identical for all manufacturers and enables vehicles to be compared.

[BUILD YOURS](#)

[BACK TO CONTENTS](#)

EQUIPMENT AND OPTIONS

	ESSENTIAL	EXPRESSION	JOURNEY
EXTERNAL APPEARANCE			
LED brand light	•	•	•
Automatic activation of daytime LED running lights	•	•	•
Grille	Black with white inserts	Black with white inserts	Black with white inserts
Dacia rear lettering	White	White	White
Front/rear bumpers	Body-coloured	Body-coloured	Body-coloured
Exterior door handles	Black	Body-coloured	Body-coloured
Door mirrors	Black	Body-coloured	Painted black
15" sheet metal Elma wheels	•	-	-
16" Atara flexwheels	-	•	-
16" Randia alloy wheels	-	-	•
Shark fin antenna	-	-	•
INTERIOR APPEARANCE			
Centre of air vents	Black and white sliders	White and white sliders	White and white sliders
Air vent surrounds	Fog Grey	Fog Grey	Fog Grey
Interior door handles	Black	Steel Grey	Steel Grey
Upholstery on the dashboard and front door armrests/trim on the front door panels	-/-	Fabric/-	Fabric/-
Split-fold rear bench 1/3 & 2/3	•	•	•
Soft feel steering wheel	-	•	•
Front door sill protection	-	-	•
Floor mats	-	-	•
Special Essential upholstery	•	-	-
Special Expression & Journey upholstery	-	•	•
ACTIVE AND PASSIVE SAFETY			
My Safety button to manage driver assistance systems	•	•	•
Anti-locking braking system (ABS) + Emergency Brake Assist (EBA)	•	•	•
Automatic emergency suburban braking with pedestrian/cyclist detection	•	•	•
Electronic Stability Control (ESC) with Hill Start Assist (HSA)	•	•	•
Emergency call (E-call)	•	•	•
Event (accident) data logger	•	•	•
Vehicle pre-configuration for alcolock immobiliser	•	•	•
Traffic sign recognition with speed alert	•	•	•
Lane change warning	•	•	•
Lane keeping assist	•	•	•
Driver attention alert	•	•	•
Front / rear "Rescue Code®" QR Code	•	•	•
Driver's front airbag / passenger's side airbag, can be deactivated	•/•	•/•	•/•
Shoulder and curtain side airbags	•	•	•
Rear parking sensors	•	•	•
Rear parking sensors with rear view camera	-	•	•
Front and rear parking sensors with camera	-	-	•
Blind spot warning	-	-	•
Electric parking brake with armrest with storage, 1 12V socket and 1 USB-C socket in the rear	-	-	•
Tyre pressure detection	•	•	•
Spare wheel + jack (excluding TCe 100 Bi-Fuel versions)	o	o	o
Tyre inflation kit	•	•	•
Isofix child seat mounting system on rear side seats	•	•	•
180 km/h / 112 mph sped limiter	•	•	•

- : not available. • : available as standard. o : available as an option.

EQUIPMENT AND OPTIONS (CONTINUED)

DRIVING AND CONTROL INSTRUMENTS

Rain and light sensors	•	•	•
Keyless entry	-	•	•
Power assisted steering	•	•	•
Stop & Start	•	•	•
On-board computer: distance travelled, average speed, range, average fuel consumption (including LPG)	•	•	•
Speed limiter / cruise control	•	•	•

VISIBILITY

Front fog lights	-	•	•
Door mirrors with interior manual adjustment	•	-	-
Electrically adjustable door mirrors	-	•	•

COMFORT

Manual heating and air conditioning system	•	•	-
Automatic heating and air conditioning system	-	-	•
Electric door locking with radio frequency remote control	•	•	•
Automatic locking of doors when in motion	•	•	•
Driver and passenger electric front windows	•	•	•
One-touch driver-seat window control (with anti-trapping function), non one-touch passenger side	-	•	•
Electric rear windows	-	•	•
Height- and reach-adjustable steering wheel	•/-	•/•	•/•
Front ceiling light	•	•	•
1 front 12 V socket	•	•	•
Modular boot with twin-level floor	-	-	•

MULTIMEDIA & AUDIO

New Media Control: DAB radio with steering wheel controls, jack socket and 2 speakers, Bluetooth® telephone system with satellite controls on the steering wheel, fixed smartphone holder on the dashboard, new Dacia Media Control smartphone app	•	-	-
Media Display: multimedia system with 8" touchscreen, DAB digital radio, smartphone mirroring via USB cable, Bluetooth® connection, satellite controls on steering wheel, 4 speakers and 1 USB-A socket	-	•	-
Media Nav: multimedia system with 8" touchscreen, navigation with MAP CARE + 6 free updates for 3 years), DAB digital radio, smartphone mirroring via USB cable or wireless via Wi-Fi, Bluetooth® connection, satellite controls on steering wheel, 6 speakers (4 loudspeakers +2 tweeters) and 1 USB-A socket	-	-	•
Removable telephone holder	-	-	•

- : not available. • : available as standard; o : available as an option.

[BUILD YOURS](#)

[BACK TO CONTENTS](#)

PRICING

	CO ₂ G/KM WLTP	FUEL TYPE	COMBINED FUEL CONSUMPTION (MPG) - WLTP	BHP	BENEFIT IN KIND	VED YEAR 1	BASIC PRICE	VAT 20%	TOTAL RETAIL PRICE	ON THE ROAD PRICE*
ESSENTIAL										
TCe 90 MY24	119	Petrol	53.3 (5.3)	90	28%	£220	£10,770.83	£2,154.17	£12,925	£13,795
TCe 100 Bi-Fuel MY24	122 (Petrol)/106 (LPG)	Petrol/LPG	52.3 (5.4) & 43.5 (6.5)	100	29%	£210	£10,779.17	£2,155.83	£12,935	£13,795
EXPRESSION										
TCe 90 MY24	119	Petrol	53.3 (5.3)	90	28%	£220	£11,604.17	£2,320.83	£13,925	£14,795
TCe 100 Bi-Fuel MY24	122 (Petrol)/105 (LPG)	Petrol/LPG	52.3 (5.4) & 43.5 (6.5)	100	29%	£210	£11,612.50	£2,322.50	£13,935	£14,795
JOURNEY										
TCe 90 MY24	119	Petrol	53.3 (5.3)	90	28%	£220	£12,437.50	£2,487.50	£14,925	£15,795
TCe 90 Auto MY24	129	Petrol	49.6 (5.7)	90	30%	£220	£13,687.5	£2,737.5	£16,425	£17,295
TCe 100 Bi-Fuel MY24	122 (Petrol)/106 (LPG)	Petrol/LPG	52.3 (5.4) & 42.8 (6.6)	100	29%	£210	£12,445.83	£2,489.17	£14,935	£15,795

* "On the Road" price includes delivery to the dealer premises, number plates, 12 months government road fund license (depending on CO₂ emissions) and First Registration Fee at £55.

OPTIONS

	ESSENTIAL	EXPRESSION	BASIC PRICE	VAT 20%	TOTAL RETAIL PRICE
Metallic & opaque paint	○	○	£541.67	£108.33	£650
Spare Wheel (excluding Bi-Fuel)	○	○	£250.00	£50.00	£300

ENJOY THE RIDE WITH DACIA ZEN



DACIA ZEN ENABLES OWNERS TO ENJOY UP TO SEVEN YEARS OF WARRANTY

- Brand new Dacia Zen warranty offers Dacia owners up to seven years of cover
- It's applicable to all Dacia models under six years old which have covered less than 75,000 miles
- Warranty is complimentary with every service completed at an official Dacia retailer
- Dacia Zen is available to owners of qualifying vehicles even if their Dacia has been previously serviced outside of the official Dacia retail network

WHO BETTER TO LOOK AFTER YOUR DACIA, THAN DACIA?

Are you the proud owner of a new or used Dacia? If your vehicle is less than 6 years old and has covered less than 75,000 miles you can get up to 7 years warranty with Dacia*

It's simple. Get your Dacia serviced by one of our expert retailers after your standard 3-year warranty expires and enjoy a Dacia ZEN warranty for a year or 18,000 miles (whichever comes sooner).

Enjoy the ride with Dacia ZEN.



Your Dacia is less than 6-years old and has done less than 75,000 miles



Have your next manufacturer service carried out in our retailer network



Get an additional 1-year of warranty*

*Warranty activated following service at participating Dacia Dealers. Valid for 1 year or 18,000 miles (whichever comes first). Vehicles over 6 years old or 75,000 miles not eligible. Full T&Cs apply.

[BOOK A SERVICE](#)

WE'VE GOT YOU COVERED

You might think our shockingly affordable prices mean our cars aren't made to last. Actually, the Dacia range is one tough cookie. To prove it, you get a 3-year* warranty (or 60,000 miles, if you reach that first). This means we will replace any part which has been deemed by a Dacia approved dealer to be defective due to a manufacturing fault, free of charge. To keep the good times rolling, you can extend your warranty up to 7 years for a great price. We also give you a 2-year paintwork and 6-year anti-corrosion warranty, so you can kick back knowing that your Dacia will stay looking good-as-new for years to come.

ROADSIDE ASSISTANCE

Although our cars are built for plain sailing, you can rely on us if you have a breakdown – 24/7 365, wherever you are in the UK or Northern Ireland. This offer also stands for the first 3 years/60,000 miles^Δ after you buy your new Dacia.

DACIA CAR INSURANCE 1

Dacia Insurance has been specifically created to provide superb protection for you and your car. Unlike most other UK insurers, in the event of an accident, your Dacia will be repaired at a Dacia Approved Bodyshop using only Dacia approved parts and approved repair methods. This maintains your Dacia's safety rating, protects its resale value and helps to maintain its Dacia warranty^Λ. Dacia Insurance also offers a courtesy car for the duration of a repair at a Dacia Approved Bodyshop.

Dacia car insurance: 0330 102 7795 www.daciacarinsurance.co.uk
Lines are open Mon - Thurs 8.30am - 7pm, Fri 9am - 6pm, Sat 9am - 5pm

SERVICING

Dacia Service Plans are the ultimate hassle free way to take care of your vehicle. Depending on the Service plan you purchase (grid below) your servicing needs are covered and you benefit from;

- Inflation Proof Servicing – You know exactly what you'll pay and there are no hidden costs
- Peace of Mind – No matter where life takes you, we'll be there in over 5000 workshops across Europe
- Dacia Expertise & Quality – Our highly trained technicians know your Dacia inside out

The Dacia Service Plan contains Dacia services in-line with the manufacturer's service schedule, plus comes with a complimentary vehicle health check to ensure your Dacia is in the best condition possible.

SERVICE PLAN ^Λ	Monthly payments
3 years / 30,000 miles Service Plan	£13.99 per month
3 years / 45,000 miles Service Plan	£21.99 per month
4 years / 48,000 miles Service Plan + 1 MOT	£19.99 per month
4 years / 60,000 miles Service Plan +1 MOT	£23.99 per month

EXTENDED WARRANTY	Total Retail Price
4 years / 100,000 miles [†]	£490
5 years / 100,000 miles [†]	£565
6 years / 100,000 miles [†]	£715

Dacia Extended warranty ends when you reach the age or mileage limit (whichever comes first).

SERVICE INTERVALS[◇]

Annual servicing **OR** servicing at 18,000 miles (whichever comes first)

Service Schedule [◇]	Year 1	Year 2	Year 3	Year 4	Year 5	Year 6
	Change Cabin Filter	Change Oil + Oil Filter	Change Cabin filter + Brake Fluid	Change Oil + Oil filter + Air filter (36k miles) + Spark Plugs (36k miles)	Change Cabin filter + Coolant (90k miles)	Change Oil + Oil Filter + Brake Fluid + Accessory Belt (90k miles)

*Dacia warranty ends when you reach the age or mileage limit (whichever comes first), from date of registration. Subject to status, terms and conditions apply. For full Dacia Extended Warranty Terms and Conditions visit www.dacia.co.uk/warranty-and-assistance/warranty

^ΔRoadside assistance for the first 3 year / 60,000 miles, which ever is reached first, from date of registration. For full Terms and Conditions visit www.dacia.co.uk/warranty-and-assistance/assistance

[†] Dacia Extended warranties are available to purchase from first date of registration up to end of manufacturer warranty. For full Dacia Extended Warranty Terms and Conditions visit www.dacia.co.uk/warranty-and-assistance/warranty

^ΛThe Service plan offer is available for eligible retail vehicles only and valid at participating dealers only. Vehicles must be ordered between 2 July to 30 September and registered by 31 December 2024. The Dacia Service plan covers the manufacturer's minimum maintenance programme requirements for the term of the Service plan purchased (refer to the Warranty and Service sheet in the Handover Document wallet for details). The plan ends when you reach the age or mileage limit (whichever comes first). Services must be carried out in line with the manufacturer's minimum maintenance programme requirements and servicing intervals within +/- 1 month or 1,000 miles of the service interval and can only be carried out at a Dacia Approved outlet. Service plans do not cover wear and tear items such as (but not limited to) tyres, wiper blades or brakes. For Service plan full Terms & Conditions visit www.dacia.co.uk/services-and-finance/service-plan. Cannot be part exchanged, refunded or transferred.

[◇] The service schedule and intervals are specific to the version and derivative of vehicle. Check with your Dacia retailer to confirm the service schedule / intervals as the above is an indicative guideline.

¹ Dacia Insurance is arranged and administered by Verex Insurance Services Ltd, which is registered in England and Wales No. 05686831 at Batchworth House, Church Street, Rickmansworth, Herts, WD3 1JE and authorised and regulated by the Financial Conduct Authority, No. 487185. Verex Insurance Services Ltd arranges policies from a panel of insurers, details are available on request.

^ΛIf your insurer uses non-approved parts which subsequently fail, they may not be covered under your manufacturer's warranty.

DIMENSIONS

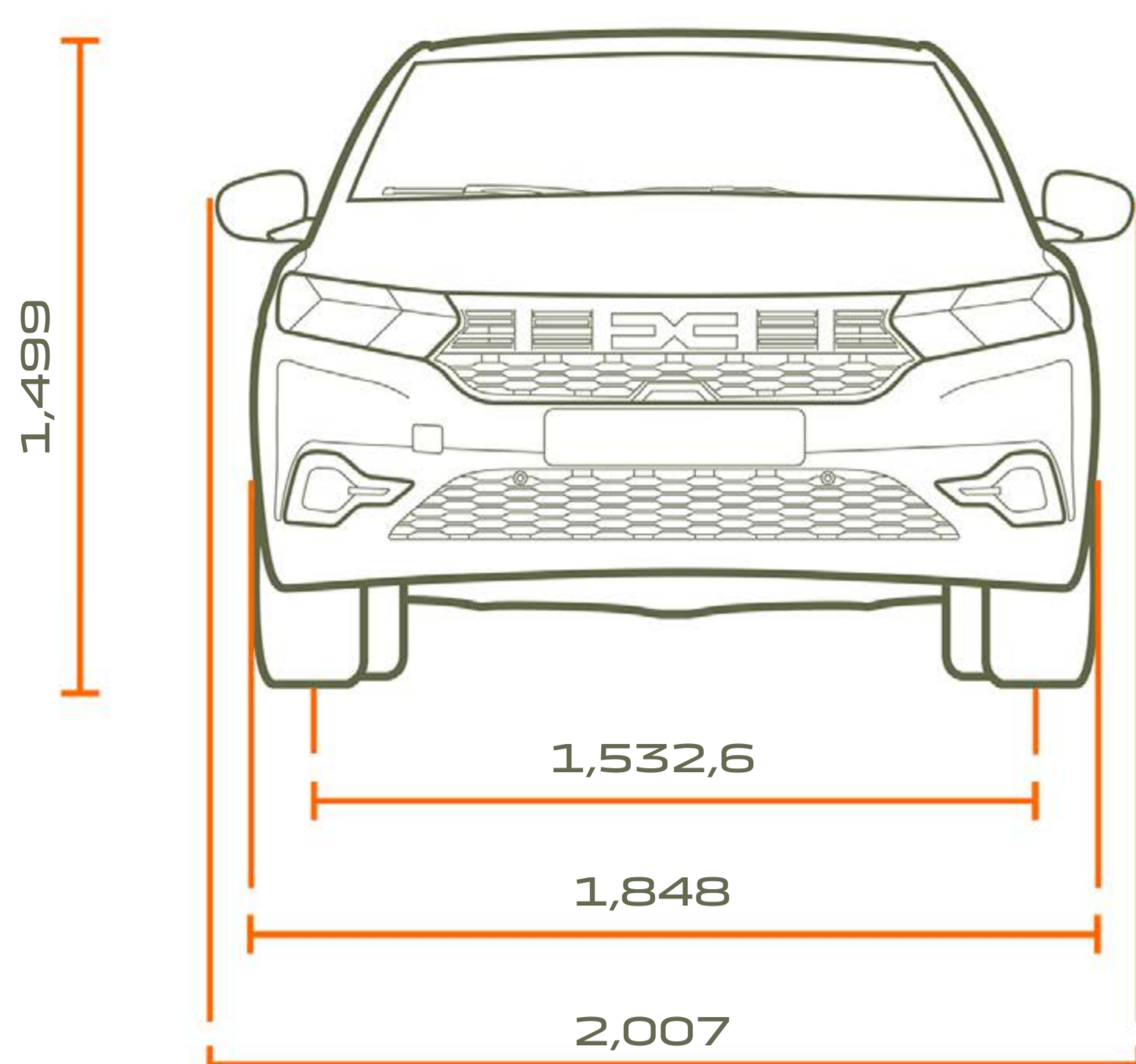

FRONT VIEW

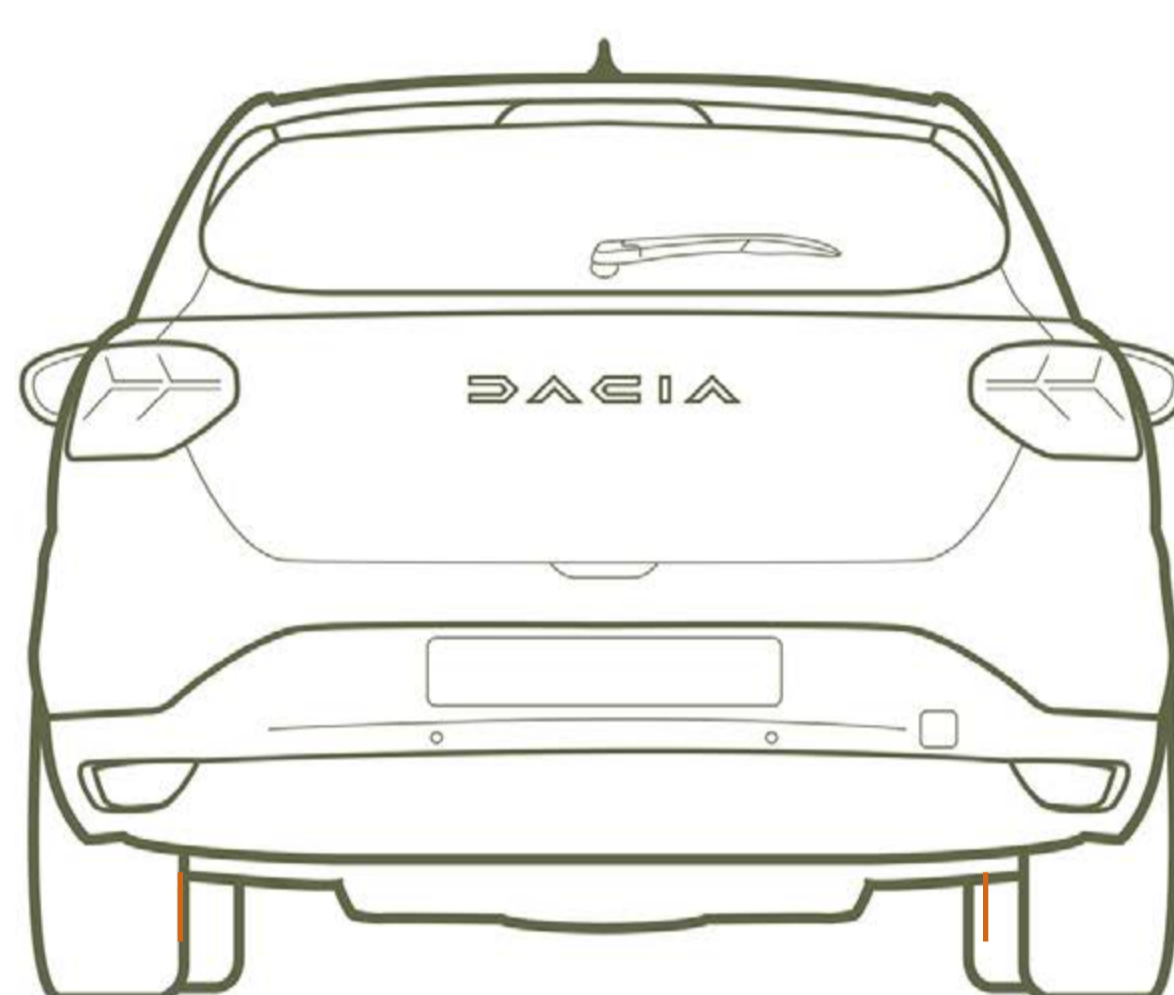

REAR VIEW

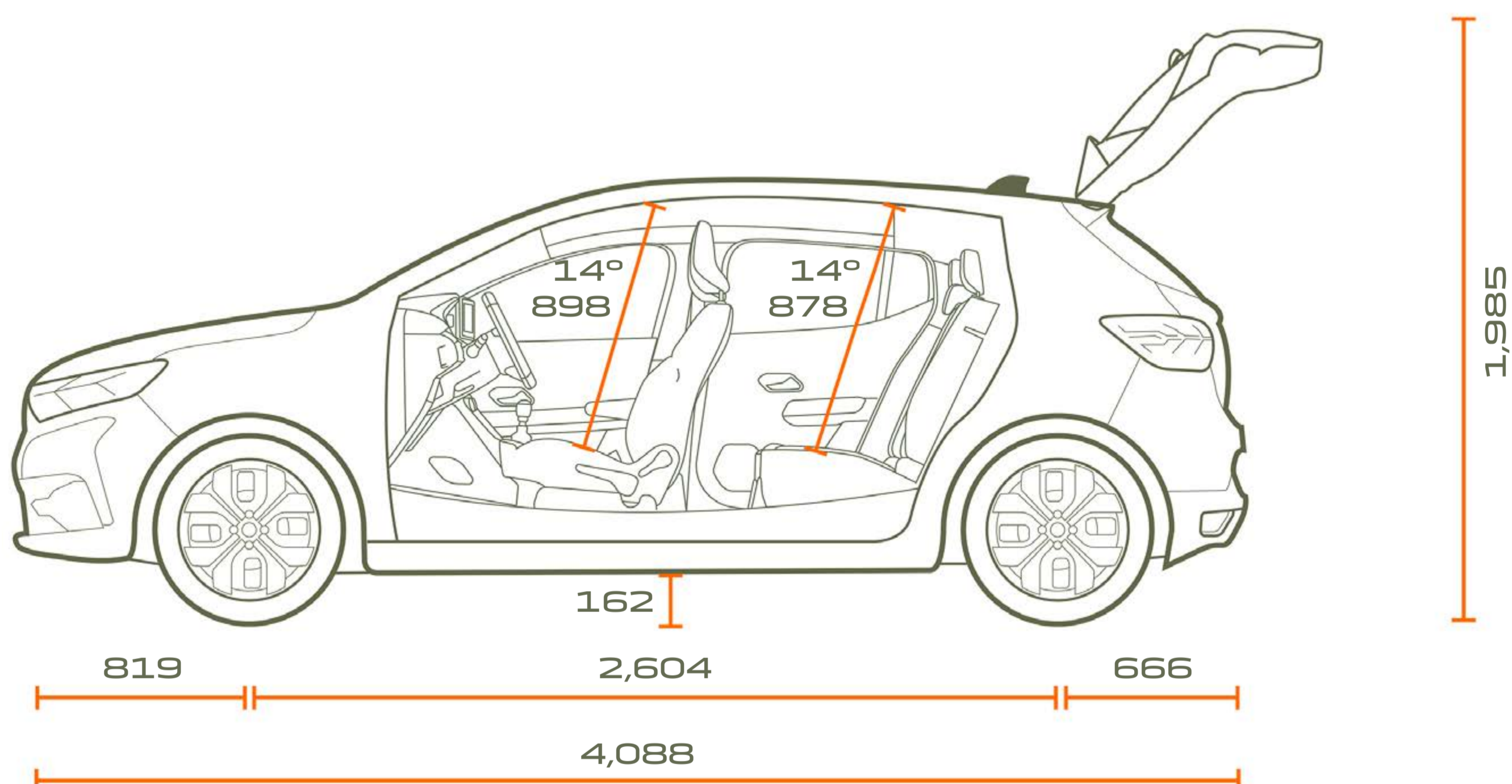

SIDE-FACE VIEW

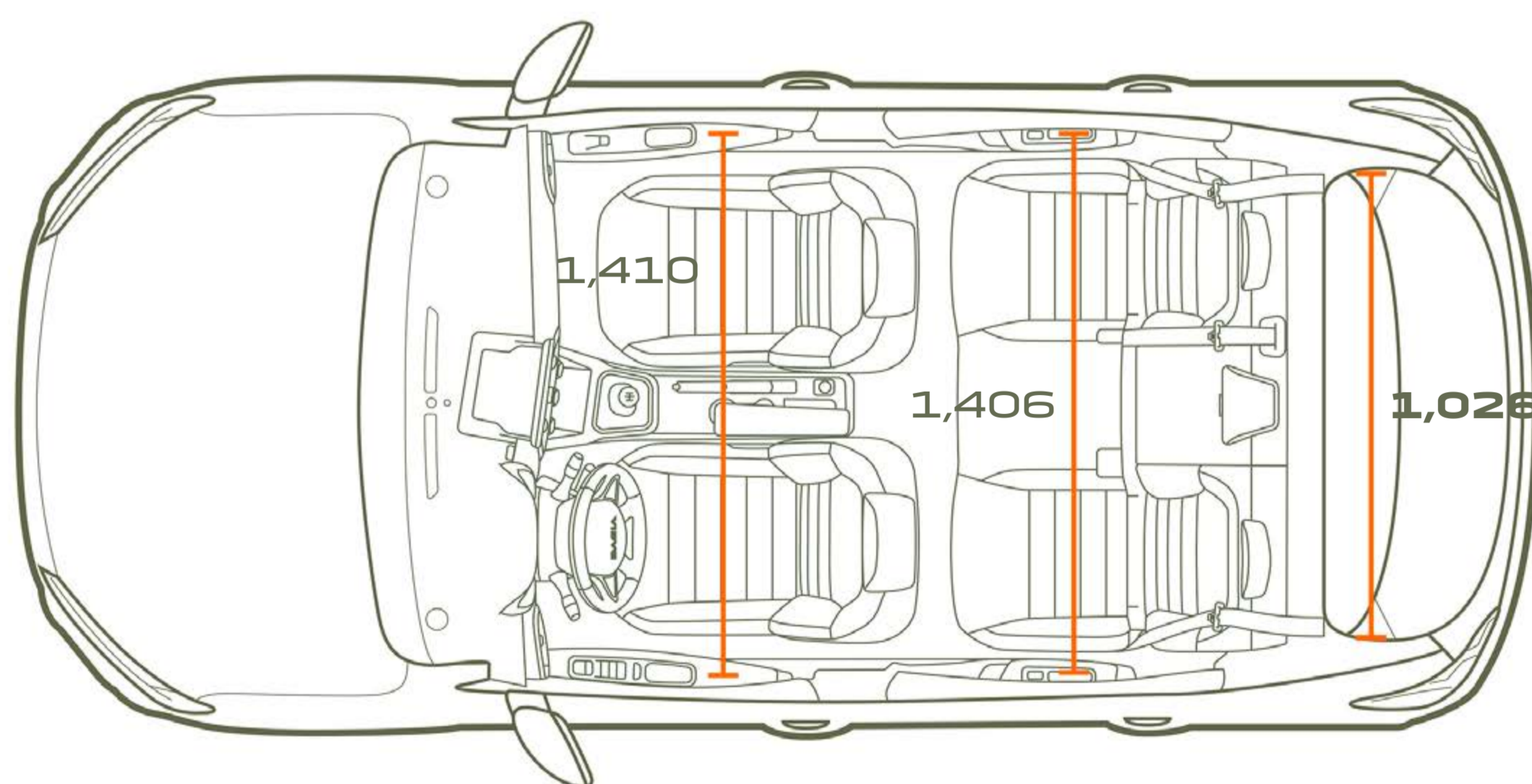

TOP VIEW

BOOT
(IN DM³ - VDA STANDARD / LITERS)

Minimum boot volume (ISO 3832)	328/410
Maximum boot volume (ISO 3832)	1,108/1,455
Volume under false floor (ISO 3832)	78

AN INCREDIBLE SUCCESS STORY

At Dacia, we offer practical and robust vehicles at the best price. Our models have a distinctive style without unnecessary frills, equipped with the most reliable and approved technologies, all at an unbeatable price. In just fifteen years, we have changed the game and disrupted the automotive market.



TO GO FURTHER

[CLICK AND CONFIGURE](#)[BOOK A TEST DRIVE](#)[FIND YOUR DEALERSHIP](#)

Access DACIA social networks:



The contents of this brochure were accurate and up-to-date at the time of publication. This document was produced based on pre-series or prototype vehicles. As part of its policy of continuous product improvement, Dacia reserves the right, at any time, to make changes to the specifications and vehicles and accessories described and illustrated. These modifications are notified to Dacia dealers as soon as possible. Depending on the country of sale, versions may differ, and some equipment may not be available (as standard, optional, or accessory). Please consult your Dacia representative for the most up-to-date information. Due to the limitations of printing, the colors shown in this document may slightly differ from the actual paint colors or interior trim materials. All rights reserved. Reproduction, in whole or in part, of this brochure in any form or by any means is prohibited without the prior written authorization of Dacia.

Dacia recommends  Castrol

PUBLICIS - PHOTO CREDITS: BAM; A. Bernier; Getty Images; Shutterstock; © RENAULT MARKETING 3D-COMMERCE – JULY 2024