

# Welcome aboard your vehicle

---

**This driver's handbook** contains the information necessary:

- for you to familiarise yourself with your vehicle, to use it to its best advantage and to benefit fully from all the functions and the technical developments it incorporates.
- to ensure that it always gives the best performance by following the simple, but comprehensive advice concerning regular maintenance.
- to enable you to deal quickly with minor faults not requiring specialist attention.

It is well worth taking a few minutes to read this handbook to familiarise yourself with the information and guidelines it contains about the vehicle and its functions and new features. If certain points are still unclear, our Network technicians will be only too pleased to provide you with any additional information.

To help you, you will find the following symbols:

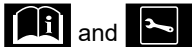

Visible on the vehicle, they show that you should consult the manual to find detailed information and/or limits on operations in respect of equipment on your vehicle.



anywhere in the manual indicates a hazard, danger or a safety recommendation.

The descriptions of the models given in this handbook are based on the technical specifications at the time of writing. **This handbook covers all items of equipment** (both standard and optional) **available for these models but whether or not these are fitted to the vehicle depends on the version, options selected and the country where the vehicle is sold.** **This manual may also contain information about items of equipment to be introduced later in the model year.** **The diagrams in the user manual are provided as examples only.**

Enjoy driving your new vehicle.

Translated from French. Copying or translation, in part or in full, is forbidden unless prior written permission has been obtained from the car manufacturer.



# C O N T E N T S

## Sections

**Getting to know your vehicle** .....

**1**

**Driving** .....

**2**

**Your comfort** .....

**3**

**Maintenance** .....

**4**

**Practical advice** .....

**5**

**Technical specifications** .....

**6**

**Alphabetical index** .....

**7**



# Section 1: Getting to know your vehicle

Key, radio frequency remote control: general information, use . . . . .	1.2
Card: general information, use . . . . .	1.5
Locking and unlocking the doors and tailgate . . . . .	1.12
Automatic locking when driving . . . . .	1.15
Opening and closing the doors . . . . .	1.16
Headrests - Seats . . . . .	1.18
Seat belts. . . . .	1.22
Methods of restraint in addition to the front seat belts. . . . .	1.28
Side protection devices . . . . .	1.33
Additional methods of restraint . . . . .	1.34
Child safety: general information. . . . .	1.35
Choosing a child seat mounting. . . . .	1.38
Fitting a child seat, general information . . . . .	1.41
Child seats: attachment by seat belt or by ISOFIX system . . . . .	1.43
Deactivating, activating the front passenger airbag . . . . .	1.51
Driving position . . . . .	1.54
Instrument panel: warning lights . . . . .	1.70
Displays and indicators . . . . .	1.76
Trip computer . . . . .	1.78
Steering wheel, Power-assisted steering . . . . .	1.91
Rear view mirrors . . . . .	1.93
Clock and outdoor temperature. . . . .	1.95
Audible and visual signals. . . . .	1.97
Exterior lighting and signals. . . . .	1.98
Adjusting the headlight beam height. . . . .	1.102
Screen washer, wiper . . . . .	1.104
Fuel tank (filling with fuel) . . . . .	1.108
Reagent tank . . . . .	1.114

# KEY, RADIO FREQUENCY REMOTE CONTROL: general information (1/2)

40617

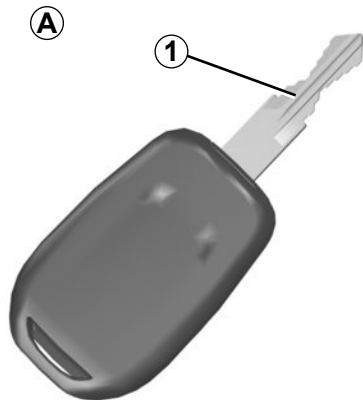

## Key A

- 1 Coded key for ignition switch, doors and fuel filler cap.

## Radio frequency remote control B or C or D

- 2 Locks all the opening elements.
- 3 Unlocks all the opening elements.
- 4 Coded key for ignition switch, driver's door and fuel filler cap.
- 5 Remote engine start-up.

40616

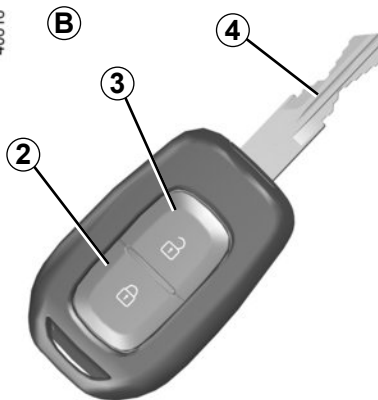

- 6 Ignition and front door key.
- 8 Locking/unlocking of the boot only.

## Remote control with switchblade key:

- 7 Locking/unlocking using the switchblade key. To release the insert from its housing, press button 7, it comes out automatically. Press button 7 and guide the insert back into its housing.

39814

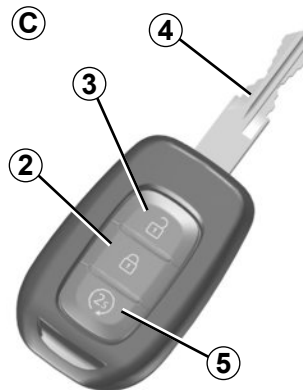

53756

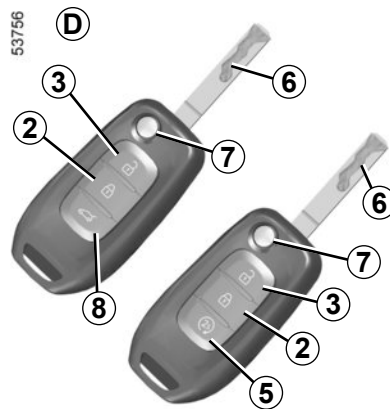

# KEY, RADIO FREQUENCY REMOTE CONTROL: general information (2/2)

## The remote control unit operating range

This varies according to the environment. It is therefore important when handling the remote control to ensure that you do not lock or unlock the vehicle by inadvertently pressing the buttons.

**Note:** if a door or the tailgate is open or not closed properly, there is a quick method for locking then unlocking them quickly.

## Interference

Interference by factors in the immediate vicinity (external installations or the use of equipment operating on the same frequency as the card) may disrupt its operation.

The key must not be used for any function other than those described in the handbook (removing the cap from a bottle, etc.).



## Driver's responsibility when parking or stopping the vehicle

Never leave an animal, child or adult who is not self-sufficient alone on your vehicle, even for a short time.

They may pose a risk to themselves or to others by starting the engine, activating equipment such as the electric windows or by locking the doors.

Also, in hot and/or sunny weather, please remember that the temperature inside the passenger compartment increases very quickly.

## RISK OF DEATH OR SERIOUS INJURY.

## Advice

Avoid leaving the remote control in hot, cold or humid areas.

## Replacement and additional keys or remote controls

If you lose your remote control key or require another, you can obtain one from an approved dealer.

If a remote control or key is replaced, it will be necessary to take the vehicle **and all of its remote control keys** to an authorised dealer to reset them.

You may use up to four remote control keys per vehicle.

## Remote control key failure

Make sure that the correct battery type is being used, and that the battery is in good condition and inserted correctly. These batteries have a service life of approximately two years.

Refer to the information on "Radio frequency remote control: Batteries" in Section 5.

# RADIO FREQUENCY REMOTE CONTROL: use

40616

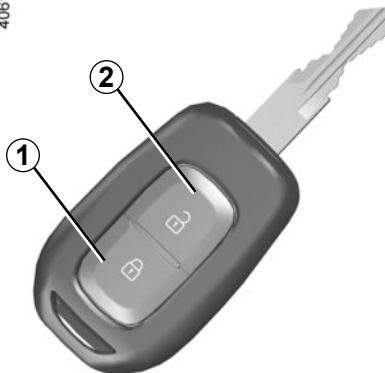

## Unlocking the doors

Press unlocking button **2**.

The hazard warning lights and side indicator lights **flash once** to indicate that the doors have unlocked.

If the vehicle has been unlocked but neither the doors or tailgate are open, it locks again automatically after two minutes.

## Locking the doors

Press locking button **1**.

The hazard warning lights and side indicator lights **flash twice** to indicate that the doors have locked.

If a door or the tailgate is open or not properly shut, the doors and tailgate lock then quickly unlock and the hazard warning lights and side indicator lights do not flash.

The key must not be used for any function other than those described in the handbook (removing the cap from a bottle, etc.).



### Driver's responsibility when parking or stopping the vehicle

Never leave an animal, child or adult who is not self-sufficient alone on your vehicle, even for a short time.

They may pose a risk to themselves or to others by starting the engine, activating equipment such as the electric windows or by locking the doors.

Also, in hot and/or sunny weather, please remember that the temperature inside the passenger compartment increases very quickly.

**RISK OF DEATH OR SERIOUS INJURY.**



## CARD: general information (1/3)

43418

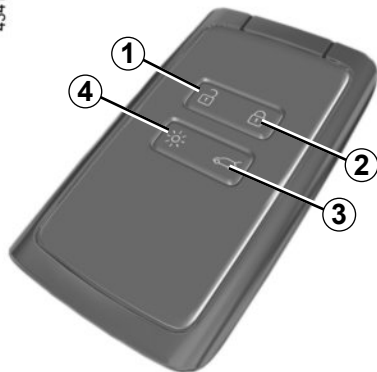

- 1 Unlocking the doors and tailgate.
- 2 Locking all doors and tailgate.
- 3 Unlocking/locking the boot.
- 4 Switching on the lighting remotely or, depending on the vehicle, starting the engine remotely.

### The card is used for:

- locking/unlocking the opening elements (doors, boot);
- switching on the vehicle lighting remotely (refer to the following pages);
- starting the engine (refer to the information on “Starting the engine” in Section 2).

### Battery life

Make sure that the correct battery type is being used, and that the battery is in good condition and inserted correctly. Its service life is approximately two years: replace it when the message “Keycard Battery Low” appears on the instrument panel (refer to section “Card: battery” in Section 5).

### Remote engine start-up

(depending on vehicle)

Press button **4** to activate the remote engine start-up. Please refer to the information on “Remote engine start-up” in Section 2.

### card operating range

This varies according to the environment: take care not to accidentally lock or unlock the vehicle by inadvertently pressing the buttons on the card.

**Note:** if a door or the tailgate is open or not closed properly, the doors and tailgate lock then unlock quickly.

### Interference

Interference by factors in the immediate vicinity (external installations or the use of equipment operating on the same frequency as the card) may disrupt its operation.

When the battery is flat, you can still lock/unlock and start your vehicle. Refer to the information on “Locking/unlocking the doors” in Section 1 and “Starting the engine” in Section 2.

## CARD: general information (2/3)

43418



### Distance lighting function

Pressing button **4** switches on the interior lighting, the side lights and the dipped beam headlights for approximately 20 seconds. This can be used, for example, to identify your vehicle from a distance when parked in a car park.

**Note:** Pressing button **4** again switches off the lighting.

### Advice

Avoid leaving the card in hot, cold or humid areas.

Do not keep the card in a place where it could be bent or damaged accidentally, such as in a back pocket of a garment.

### Replacement: need for an additional card

If you lose your card or require another, you can obtain one from an authorised dealer.

If a card is replaced, it will be necessary to take the vehicle **and all its cards** to an approved Dealer to re-set the system.

You may use up to four cards per vehicle.



### Driver's responsibility

Never leave an animal, child or adult who is not self-sufficient alone in your vehicle, even for a short time.

They may pose a risk to themselves or to others by starting the engine, activating equipment such as the electric windows or locking the doors, for example.

Also, in hot and/or sunny weather, please remember that the temperature inside the passenger compartment increases very quickly.

**RISK OF DEATH OR SERIOUS INJURY.**

## CARD: general information (3/3)

40303



### Fitting a hand strap 7

Slide the rear casing **5** downwards while pressing on zone **A**.

Never insert screwdriver-type tools into the opening **6**.

57037

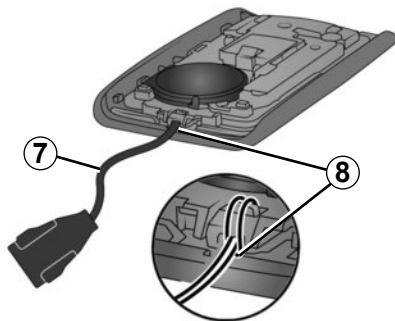

Insert the hand strap into the component **8** and pass the end of the strap through the buckle.

Position the strap at the **6** opening and close the cartridge.

**Note:** Check that the diameter of the hand strap cord **7** will fit the opening **6**.

## “HANDS-FREE” CARD: use (1/4)

There are two ways to unlock/lock the vehicle:

- the card in “hands-free” mode;
- the card in remote control mode.



Never leave your vehicle with the card inside.

Do not store the card anywhere it may come into contact with other electronic equipment (computer, phone etc.) as this could hinder its operation.



### Driver's responsibility

Never leave an animal, child or adult who is not self-sufficient alone in your vehicle, even for a short time.

They may pose a risk to themselves or to others by starting the engine, activating equipment such as the electric windows or locking the doors, for example.

Also, in hot and/or sunny weather, please remember that the temperature inside the passenger compartment increases very quickly.

**RISK OF DEATH OR SERIOUS INJURY.**



43344

### Using the card in “hands-free” mode

In “hands-free” mode, it is possible to lock/unlock the vehicle without using any of the card buttons, as long as the card is within the access zone **1**.

**Note:** if the vehicle has not been used for more than 8 days, the hands-free system switches to standby. To reactivate it, press the unlocking button on the card.

## “HANDS-FREE” CARD: use (2/4)



43344

### “Hands-free” unlocking

Card in zone **1**, the vehicle will unlock.

To indicate unlocking by **one flash** of the hazard warning lights, indicators and by the illumination of the front and rear side lights.

### Remote “Hands-free” locking

With the card on you, and doors and tailgate closed, move away from the vehicle: it will lock automatically once you have left the access zone.

**Note:** The distance at which the vehicle locks depends on the surroundings.

To indicate unlocking by **two flashes** of the hazard warning lights, indicators and by the illumination of the front and rear side lights.

The locking is confirmed by a beep.



43345

### Special features of the locking system

If a door is open or not properly closed, when you go away, the vehicle is not locked.

If the card has been within range for approximately 15 minutes, remote locking is disabled.

The vehicle will not lock if a card is in area **2**. If you unlock the vehicle by pressing the button on the card but do not open the doors or the boot, “hands-free” remote locking is disabled.

## “HANDS-FREE” CARD: use (3/4)

43418

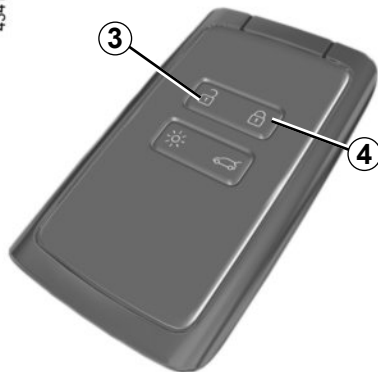

### Using the card as a remote control

#### Unlocking with the card

Press button **3**.

Unlocking is indicated by **one flash** of the hazard warning lights and the indicator lights.

If there is then an attempt trying to open a door by pressing the handle at the same time as the doors are unlocked remotely, the door concerned will remain locked. To rectify this, release the handle and unlock the vehicle again by pressing the **3** button on the card.

#### Locking using the card

With the doors and boot closed, press button **4**. The vehicle will lock. The hazard warning lights and rear indicator lights **flash twice** to indicate that the vehicle is locked.

**Note:** The maximum distance at which the vehicle locks depends on the surroundings.

#### Special features

If an opening element (a door or the luggage compartment) is open or not properly closed, the vehicle cannot be locked. The vehicle will lock/unlock in quick succession, but the hazard warning lights and the side indicator lights will not flash.

If you press button **4** for more than 5 seconds, “hands-free” mode is disabled until the next time you unlock the vehicle by pressing button **3**.

Activation or deactivation of “hands-free” mode is indicated by a beep.

The card buttons are deactivated when the engine is running.

## “HANDS-FREE” CARD: use (4/4)



43345

If, while the engine is running, a door is opened and closed, and the card is no longer in the zone **2**, the message “Keycard Not Detected” indicates that the card is not inside the vehicle. This will, for example, prevent you from driving away after dropping off a passenger who has kept the card on them.

The warning disappears when the card is detected again.

43418

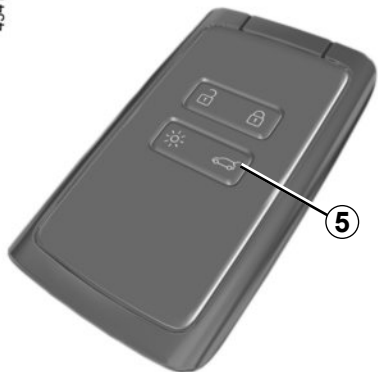

### Locking/unlocking only the boot

Press the button **5** to lock/unlock the boot only.



### Driver's responsibility when parking or stopping the vehicle

Never leave an animal, child or adult who is not self-sufficient alone in your vehicle, even for a short time.

They may pose a risk to themselves or to others by starting the engine, activating equipment such as the electric windows or locking the doors, for example.

Also, in hot and/or sunny weather, please remember that the temperature inside the passenger compartment increases very quickly.

**RISK OF DEATH OR SERIOUS INJURY.**

## LOCKING, UNLOCKING THE DOORS AND TAILGATE (1/3)

**If the remote control or, depending on the vehicle, the card does not work**

**In some cases**, the radio frequency remote control or the card may not work:

- card/radio frequency remote control battery worn or run flat, vehicle battery flat etc.
- use of appliances operating on the same frequency as the card (mobile phone, etc.);
- vehicle located in a high electromagnetic radiation zone.

It is then possible:

- depending on the vehicle, use the radio frequency remote control or the emergency key integrated in the card to unlock the front left-hand door;
- to lock each of the doors manually;
- to use the interior door locking/unlocking control (refer to the following pages).

40303



### The card's built-in key

The integrated **2** key is used to lock or unlock the front left-hand door if the card does not work.

### Access with key 2

Slide the rear casing **1** downwards while pressing on zone **A**.

39102





## LOCKING, UNLOCKING THE DOORS AND TAILGATE (2/3)

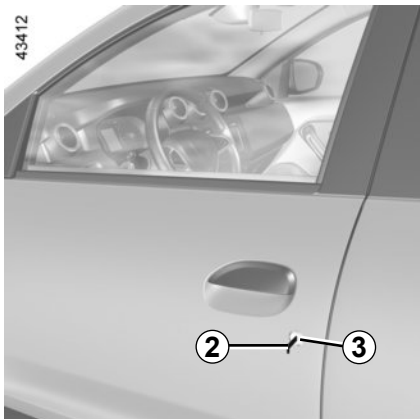

### Using the key integrated in the card

Insert the key **2** into the lock **3** and lock or unlock the front left-hand door.

Once you are inside the vehicle, put the key back in its casing in the card.

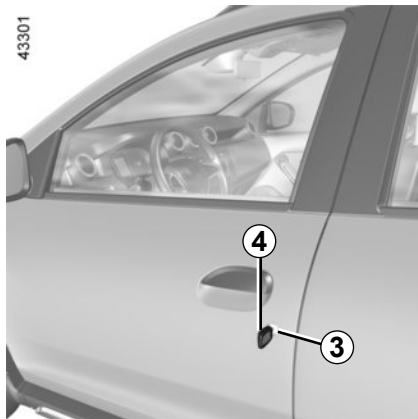

### Vehicles with key/remote control

#### Using the key

Insert the key **4** into the lock **3** and lock or unlock the front left-hand door.

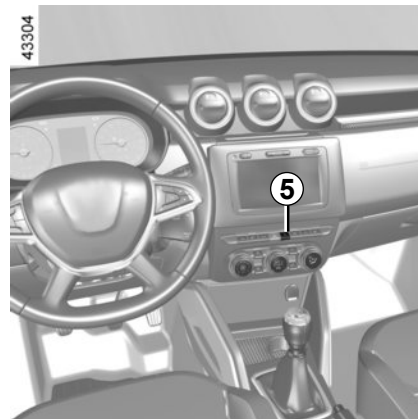

### Interior locking/unlocking door control

Depending on the vehicle, it can be used to simultaneously lock or unlock the four doors and the boot. Lock or unlock the doors by pressing switch **5**.

The front door mechanism cannot be locked if the door is open.

## LOCKING, UNLOCKING THE DOORS AND TAILGATE (3/3)

### Door and tailgate status indicator

(depending on vehicle)

**When the ignition is on**, the indicator above switch **5** comes on and informs you of the status of the doors and tailgate:

- indicator light on, the doors and tailgate are locked;
- indicator light off, the doors and tailgate are unlocked.

When you lock the doors, the indicator light remains lit and then goes out.

### Locking the opening elements without the card or the key

For example, in the event of a discharged battery or the card or key temporarily not working etc.

**With the engine switched off and a door or tailgate open**, press and hold the **5** switch for more than five seconds.

When the door is closed, all the doors and the tailgate will be locked.

Unlocking the vehicle from the outside is only possible with the card in the vehicle access zone or by using the key.



#### Driver's responsibility

If you decide to keep the doors locked when you are driving, remember that it may be more difficult for those assisting you to gain access to the passenger compartment in the event of an emergency.



Never leave your vehicle with the key or card inside.

# AUTOMATIC LOCKING WHEN DRIVING

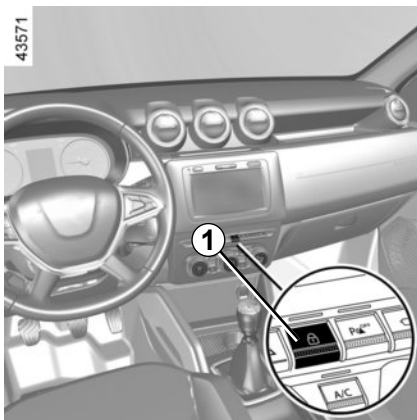

## Operating principle

After the vehicle is started, the system automatically locks the doors once your speed reaches approximately 5 mph (7 km/h).

**Note:** if a door is opened or closed, it will automatically lock again when the vehicle reaches a speed of 4 mph (7 km/h).

## Activating/deactivating the function

**To activate:** with the vehicle at a standstill and the engine running, press the switch **1** until a beep sounds.

**To deactivate:** with the vehicle at a standstill and the engine running, press the switch **1** until a beep sounds.

## Operating faults

If you notice an operating fault (automatic locking impossible), first check that all doors are correctly locked. If they are correctly locked and the fault is still present, contact an approved Dealer.

Also make sure that locking has not been inadvertently deactivated.

If this is the case, reactivate it.



### Driver's responsibility

If you decide to keep the doors locked when you are driving, remember that it may be more difficult for those assisting you to gain access to the passenger compartment in the event of an emergency.

## OPENING AND CLOSING THE DOORS (1/2)

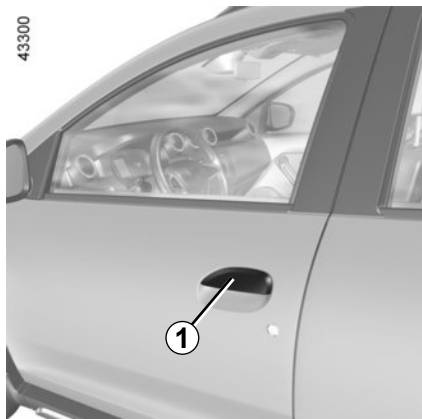

### Opening from the outside

With the doors unlocked (refer to the information on “Locking/unlocking the doors” in Section 1), place your hand below the handle **1** and pull towards you.

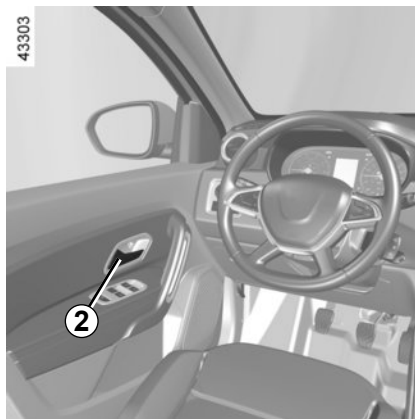

### Opening from the inside

Pull handle **2**.

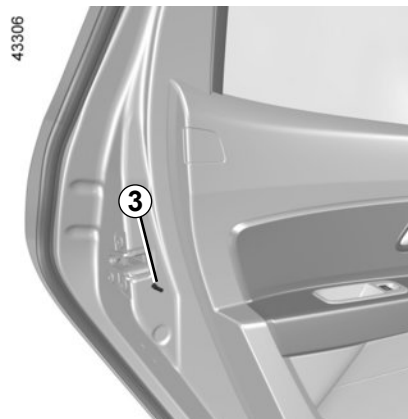

### Child safety

To make it impossible for the rear doors to be opened from the inside, move lever **3** on each door and check from the inside that the doors are securely locked.



As a safety precaution, the doors should only be opened or closed when the vehicle is stationary.

## OPENING AND CLOSING THE DOORS (2/2)

### Lights-on reminder buzzer

If you have left the lights on after switching off the ignition, a warning buzzer will sound when a front door is opened (to prevent the battery from discharging, etc.).

### Door/tailgate open buzzer

Depending on the vehicle, this alarm is fitted to the driver's side door or on all opening elements.

With the vehicle at a standstill, a warning light  will come on if a door or the boot is open or not properly closed.

While driving, as soon as the vehicle reaches 12 mph (20 km/h), a warning light  comes on with an audio beep.

### Special note

Depending on the vehicle, accessories (e.g. radio) stop working either when the engine is switched off or when the driver's door is opened or when the doors are locked.



### Driver's responsibility when parking or stopping the vehicle

Never leave an animal, child or adult who is not self-sufficient alone on your vehicle, even for a short time.

They may pose a risk to themselves or to others by starting the engine, activating equipment such as the electric windows or by locking the doors.

Also, in hot and/or sunny weather, please remember that the temperature inside the passenger compartment increases very quickly.

**RISK OF DEATH OR SERIOUS INJURY.**

# FRONT HEADRESTS

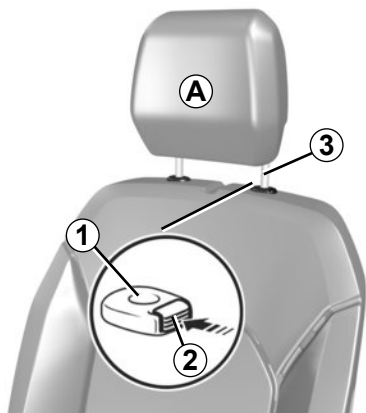

## To raise the headrest

Pull the headrest upwards to the desired height. Check that it is correctly locked.

## To lower the headrest

Press button **2** and guide the headrest down to the desired height. Check that the bonnet is correctly locked.

## To remove the headrest

Raise it to its highest position (tilt the seatback backwards if necessary). Press button **2** and lift the headrest to release it.

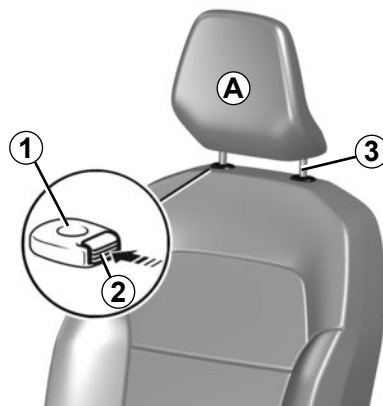

## To refit the headrest

Check that the headrest rods are clean **3**.

Insert the headrest rods into the holes **1** (tilt the seatback backwards if necessary). Lower the headrest until it locks and press button **2** to adjust to the desired height. Check that each rod **3** on the seatback is securely locked.

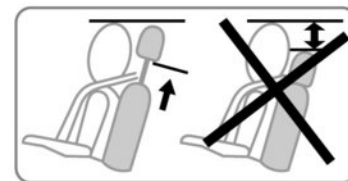

The headrest is important for safety. Ensure that it is in place and in the correct position: the top of the headrest should be as close as possible to the top of the head and there must be a minimal distance between the head and the headrest **A**.

## FRONT SEATS (1/3)

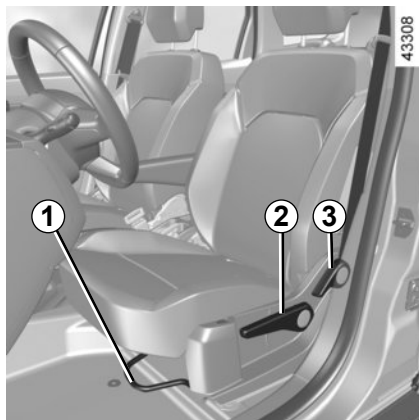

### Settings

#### To move the seat forwards or back

Lift and hold the lever **1** to unlock the seat. When the seat is in the required position, release the lever and ensure that the seat is locked in place.

#### To raise or lower the seat base

Raise or lower the handle **2** as many times as necessary until the desired position is reached.

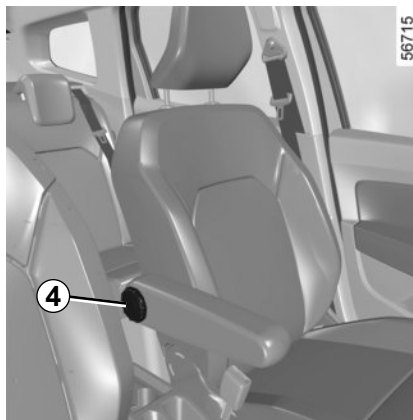

#### To tilt the seatback

Lift handle **3** and tilt the seatback to the desired position. Release the handle at the desired position and make sure that it is locked.

#### Lumbar adjustment

Turn the knob **4** or the handle **5** (depending on the vehicle) to increase or reduce the support.



After making adjustments, make sure that the seatbacks are correctly locked in place.

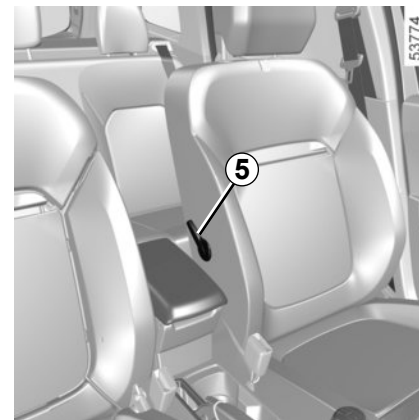

For safety reasons, carry out any adjustments when the vehicle is not being driven.

We would advise you not to recline the seatbacks too far to ensure that the effectiveness of the seat belts is not reduced.

Make sure that the seatbacks are correctly locked in place.

Nothing should be placed on the floor (area in front of driver) as such objects may slide under the pedal during braking manoeuvres, thus obstructing its use.

## FRONT SEATS (2/3)

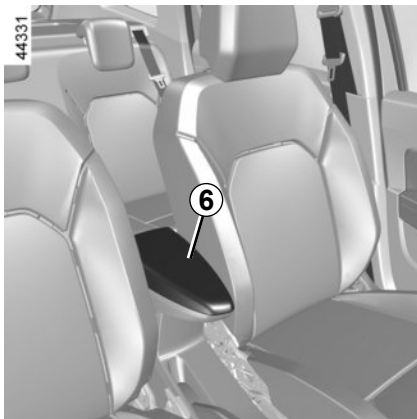

**Front armrest 6 or 7**  
(depending on vehicle)

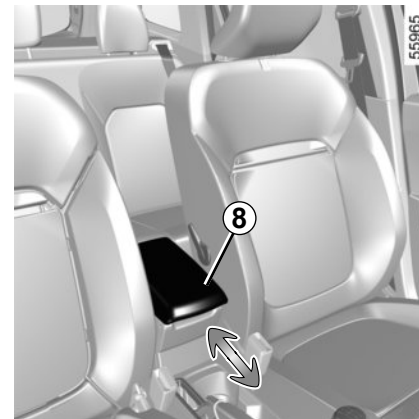
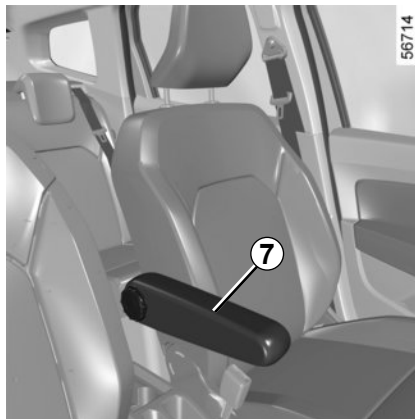

**Central armrest 8**  
(depending on the vehicle)

To adjust the position of the armrest,  
slide it forwards or backwards until it  
reaches the stop.



## FRONT SEATS (3/3)

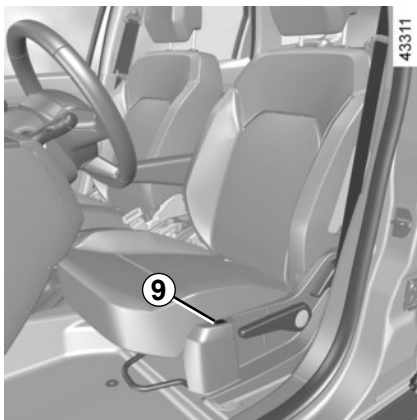

### Heated seats

Depending on the vehicle, with the ignition on, press switch **9**.

To exit this function, press switch **9** again.

The system, which has a thermostat, decides whether or not the heating is needed.

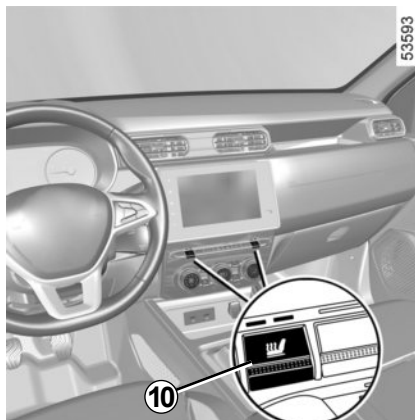

Depending on the vehicle, with the ignition on:

- pressing the switch **10** on the required seat for the first time activates the heating system at maximum power. Both integrated switch warning lights come on;
- a second press decreases the heating to minimum power. One integrated warning light comes on;
- pressing for the third time turns the heating off.

The system automatically regulates the seat temperature. When activated, it will determine if the seat heating is necessary or not.

## SEAT BELTS (1/6)

Always wear your seat belt when travelling in your vehicle. You must also comply with the legislation of the particular country you are in.

**Before starting, adjust your driving position and then have each occupant adjust their seat belt to ensure optimum protection.**

### Adjusting your driving position

(depending on the vehicle)

- **Sit well back in your seat** (having removed your coat or jacket, etc.). This is essential to ensure your back is positioned correctly;
- **adjust the distance between the seat and the pedals.** Your seat should be as far back as possible while still allowing you to fully depress the pedals. The seatback should be adjusted so that your arms are slightly bent when you hold the steering wheel;
- **adjust the position of your headrest.** For maximum safety, your head must be as close as possible to the headrest;
- **adjust the height of the seat.** This adjustment allows you to select the seat position which offers you the best possible view;
- **adjust the position of the steering wheel.**

Make sure that the rear bench seat is locked in position correctly so that the rear seat belts will operate correctly. Refer to “Rear bench seat: functions” in Section 3.



Incorrectly adjusted or twisted seat belts may cause injuries in the event of an accident.

Use one seat belt per person, whether child or adult.

Even pregnant women should wear a seat belt. In this case, ensure that the lap belt is not exerting too much pressure on the abdomen, but do not allow any slack.

## SEAT BELTS (2/6)

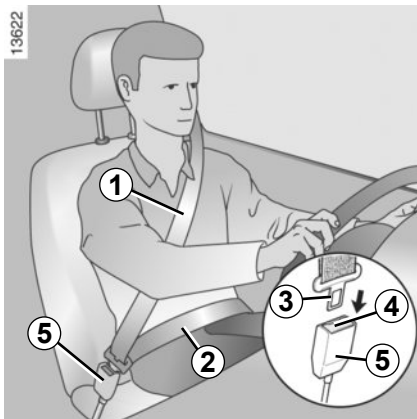

### Adjusting the seat belts

For correct adjustment and positioning of the seat belts at all seats:

- adjust the seats (seat position and seatback angle if available);
- sit with your back firmly against the seatback;
- move the shoulder strap **1** as close as possible to the base of the neck without it actually resting against it (if necessary, adjust the height of the seat belt if possible) and make sure that the shoulder strap **1** is in contact with the shoulder;

- position the lap strap **2** so that it lies flat on the thighs and against the pelvis.

The seat belt must be worn as close to the body as possible. e.g. avoid wearing heavy clothing or keeping bulky objects under the belts, etc.

### To fasten

Unwind the belt **slowly and smoothly** and ensure that buckle **3** locks into catch **5** (check that it is locked by pulling on buckle **3**).

If the belt jams, allow it to return slightly before attempting to unwind it again.

If your seat belt is completely jammed, pull slowly, but firmly, so that just over 3 cm unwinds. Allow it to return slightly before attempting to unwind it again.

If there is still a problem, contact an approved dealer.

### Unlocking

Press button **4** and the seat belt will be rewound by the inertia reel. Guide the belt.

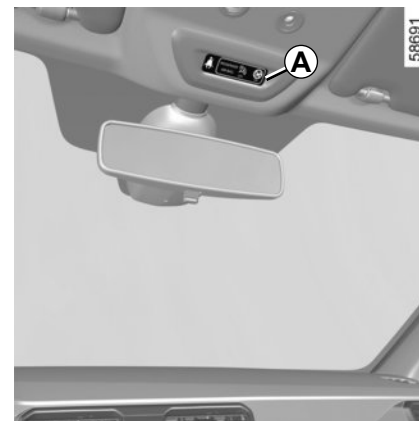

### Driver's seat belt reminder and, depending on the vehicle, front passenger seat belt reminder

This appears on the central display **A** when the ignition is switched on and if the driver's and/or front passenger's seat belt(s) (if the passenger seat is occupied) is not fastened.

Depending on the vehicle, if the seat is occupied and one of these seat belts is not fastened or becomes unfastened while the vehicle is moving at a speed over approximately 12 mph (20 km/h), the

 warning light flashes and a beep sounds for approximately 120 seconds.

**Note:** An object placed on the passenger seat may activate the warning light in some cases, depending on the vehicle.

## SEAT BELTS (3/6)

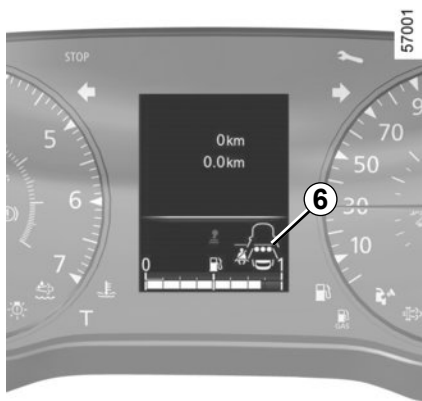

### Rear seat belt reminder

(depending on the vehicle)

The **6** graphic is displayed on the instrument panel when the ignition is switched on.

This informs the driver of the fastening status of each of the rear seat belts every time:

- the ignition is switched on;
- a door is opened;
- a rear seat belt is fastened or unfastened.

Understanding the graphic **6**:

- white symbol: seatbelt fastened;
- black symbol: seatbelt unfastened.

When the vehicle speed is below approximately 12 mph (20 km/h), the **6** symbol appears for approximately 60 seconds every time one of the rear seat belts is fastened or unfastened.

When the vehicle speed reaches or exceeds 12 mph (20 km/h), if one of the rear seat belts is unfastened during the journey:

- the  warning light flashes on the central display;

and

- a beep sounds for around 30 seconds;

and

- the **6** symbol is displayed for at least 60 seconds and the symbol for the seat concerned changes to black.

Always make sure that the rear passengers are properly fastened in and that the number of seat belts indicated corresponds to the number of rear seats occupied.

Make sure that the rear bench seat is locked in position correctly so that the rear seat belts will operate correctly. Refer to “Rear bench seat: functions” in Section 3.

## SEAT BELTS (4/6)

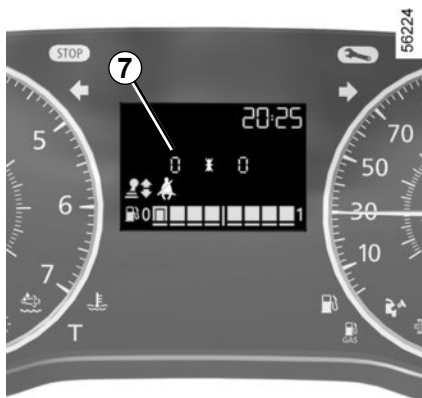

### Rear seat belt reminder

(continued)

The 7 symbol and the “Rear belts” message are displayed on the instrument panel when the ignition is switched on. This informs the driver of the fastening status of each of the rear seat belts every time:

- the ignition is switched on;
- a door is opened;
- a rear seat belt is fasted or unfastened.

Understanding the graphic 7:

- “star” symbol: seat belt fastened;
- “0” symbol: seat belt unfastened.

When the vehicle speed is below approximately 12 mph (20 km/h), the 7 symbol and the “Rear belts” message appear on the display for approximately 60 seconds every time one of the rear seat belts is fastened or unfastened.

When the vehicle speed reaches or exceeds 12 mph (20 km/h), if one of the rear seat belts is unfastened during the journey:

- the  warning light flashes on the central display;
- and
- a beep sounds for around 30 seconds;
- and
- the 7 symbol is displayed for at least 60 seconds and the symbol for the seat concerned changes to “0”.

Always make sure that the rear passengers are properly fastened in and that the number of seat belts indicated corresponds to the number of rear seats occupied.

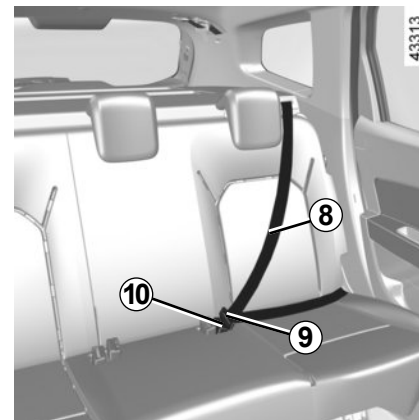

### Five-seater version

#### Rear side seat belts

Slowly unwind belt 8 and click buckle 9 into red catch 10.

## SEAT BELTS (5/6)

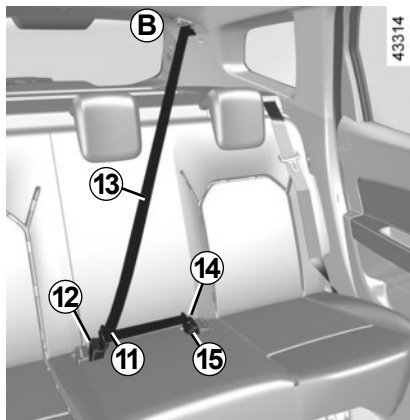

### Rear centre seat belt **B**

(depending on vehicle)

Remove the buckle **15** from its housing **16**.

Slowly unwind belt **13** and click buckle **15** into the black catch **14**.

Fasten sliding buckle **11** into red catch **12**.

Insert buckle **15** into housing **16** whenever the seat belt is not in use.

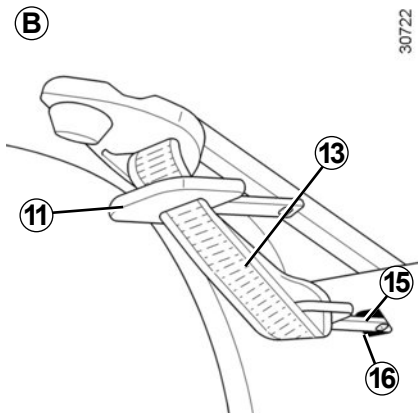

Make sure that the rear bench seat is locked in position correctly so that the rear seat belts will operate correctly. Refer to “Rear bench seat: functions” in Section 3.



Check that the rear seat belts are positioned and operating correctly each time the rear seats are moved.



### Four-seater version

This version differs in that it has rear seatbelts and headrests on the rear side seats only.

**The C label informs you that it is prohibited to seat passengers in areas other than the seats provided.**

## SEAT BELTS (6/6)

The following information applies to the vehicle's front and rear seat belts.



- No modification may be made to the component parts of the restraint system – belts and seats and their mountings – fitted originally. For special operations (e.g.: fitting child seats) contact an approved Dealer.
- Do not use devices which allow any slack in the belts (e.g. clothes pegs, clips, etc.) as a seat belt which is worn too loosely may cause injury in the event of an accident.
- Never wear the shoulder strap under your arm or behind your back.
- Never use the same belt for more than one person and never hold a baby or child on your lap with your seat belt around them.
- The belt should never be twisted.
- Following an accident, have the seat belts checked and replaced if necessary. Always replace your seat belts as soon as they show any signs of wear.
- Make sure that the buckle is inserted into the appropriate catch.
- When the rear bench seat is being put back, make sure that the seat belts and buckles are correctly positioned so that they can be used properly.
- Ensure that no objects are placed in the area around the seat belt catch as they could prevent it from being properly secured.
- Make sure the seat belt catch is properly positioned (it should not be hidden away, crushed or flattened by people or objects).

# METHODS OF RESTRAINT IN ADDITION TO THE FRONT SEAT BELTS (1/5)

Depending on the vehicle, they are composed of:

- front seat belt inertia reel pretensioners;
- chest force limiters;
- airbags driver and passenger front.

These systems are designed to act independently or together when the vehicle is subjected to a frontal impact.

Depending on the severity of the impact, the system can trigger:

- seat belt locking;
- the seat belt pretensioner to hold the occupant in the seat, and the force limiter;
- the front airbag.

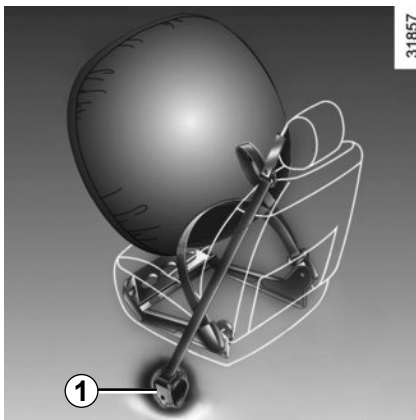

## Pretensioners

The pretensioners hold the seat belt against the body, holding the occupant more securely against the seat, thus increasing the seat belt's efficiency.

With the ignition on, following a significant frontal impact and depending on the severity of the impact, the system may trigger the seat belt inertia reel pretensioner **1**, which instantly retracts the seat belt.

## Load limiter

Above a certain level of impact force, this mechanism is used to limit the force of the belt against the body so that it is at an acceptable level.



– Have the entire restraint system checked following an accident.

– No operation whatsoever is permitted on any part of the system (pretensioners, airbags, computers, wiring) and the system components must not be reused on any other vehicle, even if identical.

– Only qualified personnel from our Network may work on the airbags; otherwise the system may trigger accidentally and cause injury.

– The electric trigger system may only be tested by a specially trained technician using special equipment.

– When the vehicle is scrapped, contact an approved dealer for disposal of the pretensioner and airbags gas generators.



# METHODS OF RESTRAINT IN ADDITION TO THE FRONT SEAT BELTS (2/5)

## driver and passenger front Airbags

These are provided for the driver and the front passenger seats (location **A**).

The presence of this equipment is indicated by the word “airbag” on the steering wheel, dashboard (in the area of the airbag **A**) and, depending on the vehicle, a label on the lower section of the windscreen.

Each airbag system consists of:

- an airbag and gas generator fitted on the steering wheel for the driver and in the dashboard for the passenger;
- an electronic unit for system monitoring which controls the gas generator electrical trigger system;
- a special warning light ;
- remote sensors.



The airbag system uses pyrotechnic principles. This explains why, when the airbag inflates, it will generate heat, produce smoke (this does not mean that a fire is about to start) and make a banging noise. In a situation where an airbag is required, it will inflate immediately and this may cause some minor, superficial grazing to the skin or other problems.

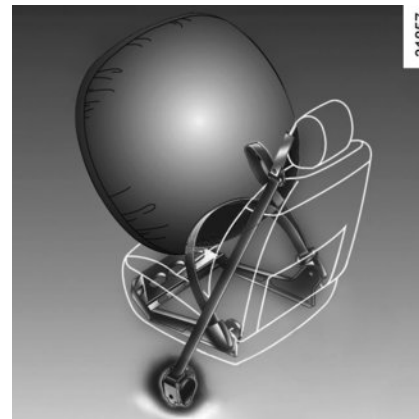

### Operation

This system is only operational when the ignition is switched on.

In a severe frontal impact, the airbags inflate rapidly, cushioning the impact of the driver's head and chest against the steering wheel and of the front passenger against the dashboard. They then deflate immediately so that the passengers are not in any way hindered when leaving the vehicle.

## METHODS OF RESTRAINT IN ADDITION TO THE FRONT SEAT BELTS (3/5)

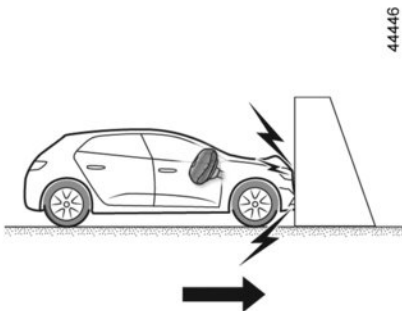

The following cases trigger the pre-tensioners or airbags:

**In a frontal impact** against a rigid (non-deformable) surface at an impact speed equal to or greater than **16 mph (25 km/h)**.

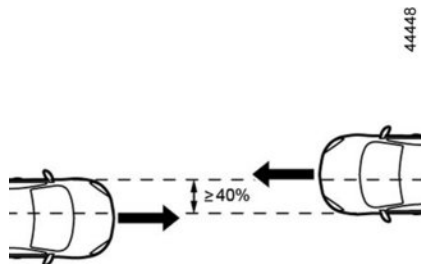

**In a frontal impact** with another vehicle of an equivalent or higher category, with an impact area equal to or greater than 40%, where the speed of both vehicles is equal to or greater than **25 mph (40 km/h)**.

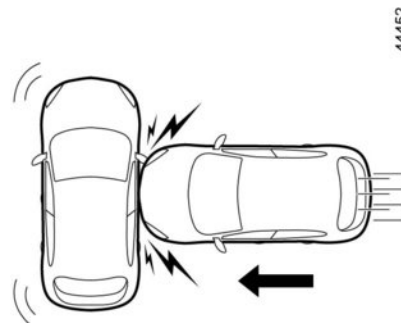

**In a side impact** with another vehicle of an equivalent or higher category, at an impact speed equal to or greater than **31 mph (50 km/h)**.

## METHODS OF RESTRAINT IN ADDITION TO THE FRONT SEAT BELTS (4/5)



**In the following examples, the pretensioners and airbags could operate:**

- impacts to the underside of the vehicle, from kerbs, for example;
- potholes;
- a fall or a hard landing;
- stones;
- ...

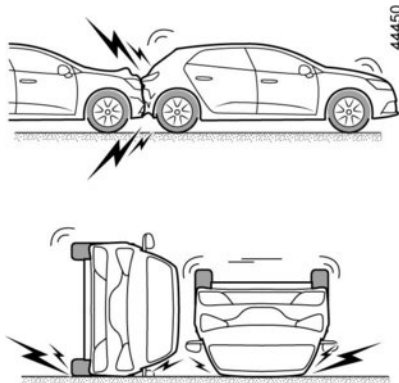

**In the following examples, the pretensioners and airbags might not operate:**

- rear impact, however severe;
- the vehicle overturning;

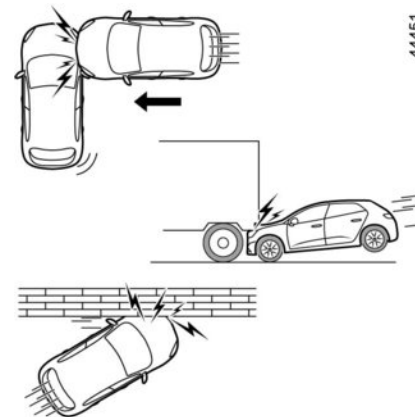

- side impact to the front or rear of the vehicle;
- frontal impact, under the tail of a lorry;
- frontal impact against an obstacle with a sharp angle;
- ...

## METHODS OF RESTRAINT IN ADDITION TO THE FRONT SEAT BELTS (5/5)

All of the warnings below are given so that the airbag is not obstructed in any way when it is inflated and also to prevent the risk of serious injuries caused by items which may be dislodged when it inflates.



### **Warnings concerning the driver's airbag**

- Do not modify the steering wheel or the steering wheel boss.
- Do not cover the steering wheel boss under any circumstances.
- Do not attach any objects (badge, logo, clock, telephone holder, etc.) to the steering wheel boss.
- You must not remove the steering wheel (such work must only be performed by trained personnel from our Network).
- Do not sit too close to the steering wheel when driving: sit with your arms slightly bent (see “Adjusting your driving position” in Section 1). This will allow sufficient space for the airbag to deploy correctly and be fully effective.

### **Warnings concerning the passenger airbag**

- Do not attach or glue any objects (badge, logo, clock, telephone holder, etc.) to the dashboard on or near the airbag.
- Do not place anything between the dashboard and the passenger (pet, umbrella, walking stick, parcels, etc.).
- The passenger must not put his or her feet on the dashboard or seat as there is a risk that serious injuries may occur. In general, all parts of the body should be kept away from the dashboard (knees, hands, head etc.).
- Reactivate the passenger airbag as soon as you remove the child seat to ensure the protection of the front passenger in the event of an impact.

**A REAR-FACING CHILD SEAT MUST NOT BE FITTED TO THE FRONT PASSENGER SEAT UNLESS THE RESTRAINT SYSTEMS IN ADDITION TO THE SEAT BELT, I.E. AIR BAG, ARE DEACTIVATED.**

(refer to the information on “Child safety: deactivating/activating the front passenger airbag” in Section 1)

# SIDE PROTECTION DEVICES

## Side Airbags

These airbags may be fitted to the front seats and are deployed at the sides of the seats (door side) to protect the occupants in the event of a severe side impact.

## Curtain Airbags

These are airbag fitted along the sides of the vehicle in the ceiling which trigger along the front and rear door side windows to protect the passengers in case of a severe side impact.

Depending on the vehicle, a marking on the windscreen informs you of the presence of additional means of restraint (airbags, pretensioners etc.) in the passenger compartment.



### Warning relating to the side airbag

- **Fitting seat covers:** seats equipped with an airbag require covers specifically designed for your vehicle. Contact an approved dealer to find out if such covers are available from our Network. The use of any covers other than those designed for your vehicle (including those designed for another vehicle) may affect the operation of the airbags and reduce your protection.
- In the front, do not place any accessories, objects or even pets between the seatback, the door and the internal fittings. Do not cover the seatback with objects such as clothes or accessories. This may prevent the airbag from operating correctly or cause injury when the airbag is deployed.
- No work or modification whatsoever may be carried out on the seat or internal fittings, except by qualified personnel from our Network.

## ADDITIONAL METHODS OF RESTRAINT

All of the warnings below are given so that the airbag is not obstructed in any way when it is inflated and also to prevent the risk of serious injuries caused by items which may be dislodged when it inflates.



The airbag is designed to complement the action of the seat belt. Both the airbag and the seat belt are integral parts of the same protection system. It is therefore essential to wear seat belts at all times. If seat belts are not worn, the occupants are exposed to the risk of serious injury in the event of an accident. It may also increase the risk of minor superficial injuries occurring when the airbag is deployed, although such minor injuries are always possible with airbags.

If the vehicle should overturn or suffer a rear impact, however severe, the pretensioners and airbags are not always triggered. Shocks to the underbody of the vehicle, from pavements, potholes, stones etc. can all trigger these systems.

- No work or modification **whatsoever** may be carried out on any part of the driver or passenger airbag system (airbag, computer, wiring harness etc.), except by qualified network personnel.
- To ensure that the system is in good working order and to avoid accidental triggering of the system which may cause injury, only qualified Network personnel may work on the airbag system.
- As a safety precaution, have the airbag system checked if your vehicle has been involved in an accident, or is stolen or broken into.
- When selling or lending the vehicle, inform the user of these points and hand over this driver's handbook with the vehicle.
- When scrapping your vehicle, contact your approved Dealer for disposal of the gas generator(s).

## Operating faults

This warning light  will light up on the instrument panel when the ignition is switched on and then go out after a few seconds.

If it does not light up when the ignition is switched on or if it comes on when the engine is running, accompanied by the warning light  and, depending on the vehicle, the message "WARNING: Check Airbag", there is a system fault. In this case, it is PROHIBITED to fit a child seat on the front passenger seat.

Contact an approved dealer as soon as possible. Your protection will be reduced until this fault is rectified.

## CHILD SAFETY: General information (1/2)

### Carrying children

Please ensure that you comply with the legislation of your country.

Children, and adults, must be correctly seated and strapped in for all journeys. The children being carried in your vehicle are your responsibility.

A child is not a miniature adult. Children are at risk of specific injuries as their muscles and bones have not yet finished growing. The seat belt alone would not provide suitable protection. Use an approved child seat and ensure you use it correctly.



To prevent the doors being opened, use the childproof locks (refer to the information on “Locking/unlocking the opening elements” in Section 1).



A collision at 30 mph (50 km/h) is the same as falling a distance of 10 metres.

Transporting a child without a restraint is the equivalent of allowing him or her to play on a fourth-floor balcony without railings.

Never travel with a child held in your arms. In the event of an accident, you will not be able to keep hold of the child, even if you yourself are wearing a seat belt.

If your vehicle has been involved in a road accident, replace the child seat and have the seat belts and ISOFIX anchorage points checked.



### **Driver's responsibility when parking or stopping the vehicle**

Never leave an animal, child or adult who is not self-sufficient alone on your vehicle, even for a short time.

They may pose a risk to themselves or to others by starting the engine, activating equipment such as the electric windows or by locking the doors.

Also, in hot and/or sunny weather, please remember that the temperature inside the passenger compartment increases very quickly.

**RISK OF DEATH OR SERIOUS INJURY.**

## CHILD SAFETY: General information (2/2)

### Using a child seat

The level of protection offered by the child seat depends on its ability to restrain your child and on its installation. Incorrect installation compromises the protection it offers the child in the event of harsh braking or an impact.

Before purchasing a child seat, check that it complies with the regulations for the country you are in and that it can be fitted in your vehicle. Consult an approved dealer to find out which seats are recommended for your vehicle.

The regulations on transporting children are specific to each country.

The use of a child seat during transport depends on the age and/or the size and/or weight of the child.

For children who do not need to be transported to a child seat, make sure that the seat belt is correctly adjusted and fastened.

In all cases, you must comply with the regulations of the particular country you are in.

Before fitting a child seat, read the manual and respect its instructions. If you experience any difficulties during installation, contact the manufacturer of the equipment. Keep the instructions with the seat.

Set a good example by always fastening your seat belt and teaching your child:

- to strap themselves in correctly;
- to always get in and out of the car at the kerb, away from busy traffic.

Do not use a second-hand child seat or one without an instruction manual.

Check that there are no objects in the vicinity of the child seat which could impede its operation.



Never leave a child unattended in the vehicle.

Check that your child is always strapped in and that the belt or safety harness used is correctly set and adjusted. Avoid using excessively thick clothes that create clearance with the seat belts (see the information on “Seat belts” in Section 1).

Never let your child put their head or arms out of the window.

Check that the child is in the correct position for the entire journey, especially if asleep.



## CHILD SAFETY: choosing a child seat



31235

### Rear-facing child seats

A baby's head is, proportionally, heavier than that of an adult and its neck is very fragile. Transport the child in this position for as long as possible (until the age of 2 at the very least). It supports the head and neck. Choose a bucket type seat for better side protection and replace it as soon as the child's head extends past the seat shell.



38824

### Forward-facing child seats

Up to 18 kg or 4 years, the child may travel on a forward-facing seat. Choose a seat according to the size of the child: the head and abdomen, etc.

The child's head and abdomen need to be protected as a priority. A forward-facing child seat which is firmly attached to the vehicle will reduce the risk of impact to the head. Ensure your child travels in a forward-facing seat with a harness for as long as their size permits. Choose a bucket type seat for optimum side protection.



31234

### Booster cushions

From 15 kg or 4 years, the child can travel using a booster seat, which will enable the seat belt to be adapted to suit his/her size and shape. The booster seat cushion must be fitted with guides to position the seat belt on the child's thighs rather than the stomach. It is recommended that you use a seat-back fitted with a belt strap guide which can be adjusted in terms of height to position the seat belt in the centre of the shoulder. It should never rest on the neck or over the arm. Choose a bucket type seat for better side protection.

## CHILD SAFETY: choosing a child seat mounting (1/3)

There are two ways of attaching child seats: via the seat belt or using the ISOFIX system.

### Attachment via the seat belt

The seat belt must be adjusted to ensure that it is effective in the event of harsh braking or an impact.

Ensure that the strap paths indicated by the child seat manufacturer are respected.

Always check that the seat belt is correctly fastened by pulling it up, then pulling it out fully whilst pressing on the child seat.

Check that the seat is correctly held by moving it from side to side and back to front: the seat should remain firmly fixed.

Check that the child seat has not been installed at an angle and that it is not resting against a window.



Do not use the child seat if it may unfasten the seat belt restraining it: the base of the seat must not rest on the buckle and/or catch of the seat belt.



The seat belt must never be twisted or the tension relieved. Never pass the shoulder strap under the arm or behind the back. Check that the seat belt has not been damaged by sharp edges. If the seat belt does not operate normally, it will not protect the child. Consult an approved dealer. Do not use this seat until the seat belt has been repaired.

## CHILD SAFETY: choosing a child seat mounting (2/3)

### Attachment using the ISOFIX system

Approved child seats ISOFIX are standardised in accordance with current regulations if any of the four cases below applies:

- ISOFIX universal 3-point forward-facing seat;
- ISOFIX semi-universal 2-point seat;
- Specific;
- i-Size Which has:
  - either a belt which attaches to the third ring of the seat concerned;
  - or a strut that rests on the vehicle floor, compatible with the approved seat i-Size, the role of which is to prevent the child seat from moving in the event of a collision.

In the latter three cases check that your child seat can be installed by consulting the list of compatible vehicles.

Attach the child seat with the ISOFIX locks, if these are provided. The ISOFIX system allows quick, easy, safe fitting.

The ISOFIX system consists of 2 rings and, in some cases, a third ring.



No modifications may be made to the component parts of the restraint system (ISOFIX seat belts, seats and their mountings) originally fitted.



Before using an ISOFIX child seat that you purchased for another vehicle, check that its installation is authorised. Consult the list of vehicles which can be fitted with the seat from the equipment manufacturer.

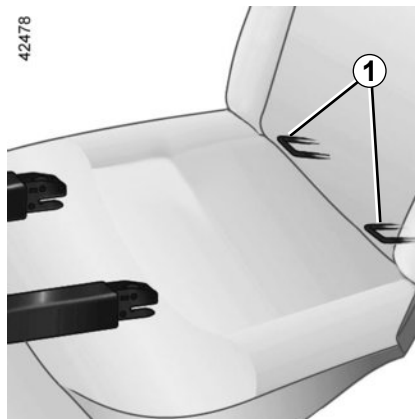

The two rings **1** are located between the seatback and the seat base of the seat and are identified by a marking.

## CHILD SAFETY: choosing a child seat mounting (3/3)

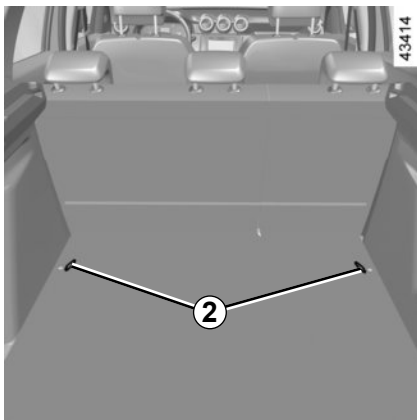

The third ring of each side seat is used to attach the upper strap on some child seats.

Pass the belt between the seatback and the rear parcel shelf (to remove the parcel shelf: refer to Section 3 "Parcel shelf").

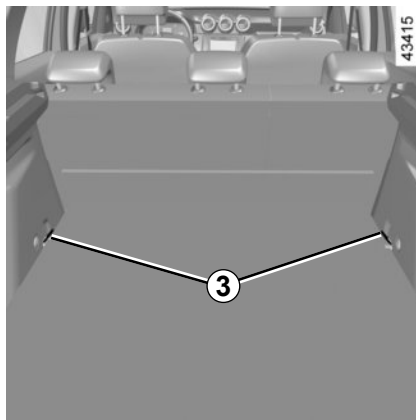

Attach the hook on the belt to one of the rings **2** (version 4x2) or **3** (version 4x4).

Pull the belt so that the back of the child seat comes into contact with the back of the vehicle seat.



The ISOFIX anchorage points have been exclusively designed for child seats with the ISOFIX system. Never fit a different type of child seat, seat belt or other objects to these anchorage points.

Check that nothing is obstructing the anchorage points.

If your vehicle has been involved in a road accident, have the ISOFIX anchorage points checked and replace your child seat.

**Note:** it is **essential** to use the rings marked with the symbol .



Check that the seatback of the forward-facing child seat is in contact with the seatback of the vehicle seat. In this case, the child seat may not always rest on the seat base of the vehicle seat.



The child seat strap **must** be attached to the corresponding ring.

## CHILD SAFETY: fitting a child seat, general information (1/2)

Some seats are not suitable for fitting child seats. The diagram on the following page shows you how to attach a child seat.



Fit the child seat in a rear seat wherever possible.

Make sure that the child seat or the child's feet do not prevent the front seat from locking correctly. Refer to the information on the "Front seat" in Section 1.

Check that when installing the child seat in the vehicle it is not at risk of coming loose from its base.

If you have to remove the headrest, check that it is correctly stored so that it does not come loose under harsh braking or impact.

Always attach the child seat to the vehicle even if it is not in use so that it does not come loose under harsh braking or impact.

The types of child seat indicated may not be available. Before using a different child seat, check with the manufacturer that it can be fitted.

### In the front seat

The laws concerning children travelling in the front passenger seat differ in every country. Consult the legislation in force and follow the indications on the diagram on the following page.

Before installing a child seat on this seat (if authorised and depending on the vehicle):

- lower the seat belt as far as possible;
- move the seat as far back as possible;
- gently tilt the seatback away from vertical (approximately 25°);
- raise the seat base fully.

In all situations, reinsert the headrest to its full extent so that it does not interfere with the child seat (see the information on "Front headrests" in Section 1);

After installing the child seat, push the front passenger seat at least one notch. In the case of a rear-facing child seat, do not let it touch the dashboard.

Do not change other settings after installing the child seat.



### **RISK OF DEATH OR SERIOUS INJURY:**

before fitting a rear-facing child seat to this seat, check that the airbag has been deactivated (refer to the information on "Child safety: deactivating/activating the front passenger airbag" in Section 1).

## CHILD SAFETY: fitting a child seat, general information (2/2)

### In the rear side seat

A carrycot can be installed across the vehicle and will take up at least two seats. Position the child with his or her feet nearest the door.

Before installing a child seat in the ISOFIX anchoring points on a rear side seat, check that the seat belt buckles are not placed between the two ISOFIX anchorage points in this seat. If necessary, move the buckle from the seat in question towards the centre of the vehicle.

Move the front seat as far forward as possible to install a rear-facing child seat, then move back the seat in front as far as it will go, although without allowing it to come into contact with the child seat.

For the safety of a child in the facing forwards, move the seat as far back as possible and move the seat in front of the child forward, remembering to move the seatback forwards to avoid contact between the seat and the child's legs.

Always remove the headrest from the rear seat used for the child seat (see "Rear headrests" in Section 3).

Check that the child seat is resting against the back of the vehicle seat.



Ensure that the child seat or the child's feet do not prevent the front seat from locking correctly. Refer to the information on the "Front seat" in Section 1 or "Rear seat operation" in Section 3.



A child seat with floor supports must never be installed on the rear centre seat. **RISK OF DEATH OR SERIOUS INJURY.**



### Installing a booster seat (group 2 or 3)

Check that the seat belt is operating (winding) correctly: refer to the information on "Seat belts" in Section 1.

Adjust the seat belt by positioning:

- the shoulder strap on the child's shoulder without it touching the neck;
- the lap belt so that it lies flat on the thighs and against the pelvis.

If necessary, adjust the position of the vehicle seat.

## CHILD SEATS: attachment by seat belt (1/4)

### Visual installation of the five-seater version



59728



Using a child safety system which is not approved for this vehicle will not correctly protect the baby or child. They risk serious or even fatal injury.



Seat not suitable for fitting child seats.

#### Child seat attached using the belt



Seat which allows a child seat with "Universal" approval to be attached by a seat belt.

**B2:** Seat enabling a child seat with "B2" approval to be attached by seat belt.



Check that your child is always strapped in and that the harness or seat belt is correctly adjusted: see the information on "Seat belts" in Section 1.

If necessary, adjust the seat position accordingly.

## CHILD SEATS: attachment by seat belt (2/4)

### Visual installation of four-seater version



59729



Using a child safety system which is not approved for this vehicle will not correctly protect the baby or child. They risk serious or even fatal injury.



Seat not suitable for fitting child seats.

#### Child seat attached using the belt



Seat which allows a child seat with "Universal" approval to be attached by a seat belt.



Carrying a passenger is **STRICTLY PROHIBITED**.

**B2:** Seat enabling a child seat with "B2" approval to be attached by seat belt.



Check that your child is always strapped in and that the harness or seat belt is correctly adjusted: see the information on "Seat belts" in Section 1.

If necessary, adjust the seat position accordingly.



## CHILD SEATS: attachment by seat belt (3/4)

The table below summarises the information already shown on the diagram on the previous pages, to ensure the regulations in force are respected.

Type of child seat	Weight of the child	Front passenger seat without airbag or with airbag deactivated	Front passenger seat with airbag without deactivation	Rear side seats	Rear centre seat, five-seater version ONLY
<b>Carrycot fitted across the vehicle</b> Group 0	< 10 kg	X	X	U (1)	X
<b>Rear-facing shell seat</b> Groups 0 or 0 +	< 10 kg and < 13 kg	X	X	U (2)	U (2)
<b>Shell seat/rear-facing seat</b> Groups 0+ and 1	< 13 kg and 9 to 18 kg	X	X	U (2)	U (2)
<b>Forward-facing seat</b> Group 1	9 to 18 kg	X	X	U (3)	U (3)
<b>Booster seat</b> Groups 2 and 3	15 to 25 kg and 22 to 36 kg	X	X	U - B2 (3)	U (3)

## **CHILD SEATS: attachment by seat belt (4/4)**

X = Seat not suitable for fitting child seats of this type.

U = Seat allowing a child seat with “Universal” approval to be attached by the seat belt; check that it can be fitted.

B2 = Booster seats in groups 2 and 3 (15 to 25 kg and 22 to 36 kg).

- (1)** A carrycot can be installed across the vehicle and will take up at least two seats. Position the child with his or her feet nearest the door.
- (2)** If necessary, position the vehicle seat as far back as possible. Move the front seat as far forward as possible to install a rear-facing child seat, then move back the seat in front as far as it will go, although without allowing it to come into contact with the child seat.
- (3)** In all situations, remove the rear headrest of the seat on which the child seat is positioned. This must be done before fitting the child seat. Please refer to the information on the “Rear headrests” in Section 3. Move the seat in front of the child forwards, move the seatback forward to avoid contact between the seat and the child’s legs.

## CHILD SEATS: fitted using the ISOFIX SYSTEM (1/4)

To ensure you comply with the applicable regulations, the table below summarises the information shown in the diagram on the following pages.

Type of child seat	Weight of the child	Seat size ISOFIX [Gabarit]	Front passenger seat	Rear side seats	Rear centre seat Five-seater version ONLY
<b>Carrycot fitted across the vehicle</b> Group 0	< 10 kg	L1 [F], L2 [G]	X	X	X
<b>Rear-facing shell seat</b> Groups 0 or 0 +	< 13 kg	R1 [E]	X	IL (1)	X
<b>Rear-facing seat</b> Groups 0+ and 1	< 13 kg and 9 to 18 kg	R3 [C], R2 [D]	X	IL (1)	X
<b>Forward-facing seat</b> Group 1	9 to 18 kg	F3 [A], F2 [B], F2X [B1]	X	IUF - IL (2)	X
<b>Booster seat</b> Groups 2 and 3	15 to 25 kg and 22 to 36 kg	B2	X	IUF - IL (2)	X

<b>Seat i-Size</b>			X	i-U	X
--------------------	--	--	---	-----	---

## CHILD SEATS: fitted using the ISOFIX SYSTEM (2/4)

**X** = Seat not suitable for fitting child seats ISOFIX.

**IUF/IL** = On equipped vehicles, seat which allows an approved “Universal/semi-universal” or “vehicle specific” child seat to be attached using the ISOFIX system; check that it can be fitted.

**i-U** = Suitable for the i-Size restraint devices in the “universal” forward-facing and backward-facing category.

- (1) If necessary, position the vehicle seat as far back as possible. Move the front seat as far forward as possible to install a rear-facing child seat, then move back the seat in front as far as it will go, although without allowing it to come into contact with the child seat.
- (2) In all situations, remove the rear headrest of the seat on which the child seat is positioned. This must be done before fitting the child seat. Please refer to the information on the “Rear headrests” in Section 3. Move the seat in front of the child forwards, move the seatback forward to avoid contact between the seat and the child’s legs.

The size of the ISOFIX child seat is indicated by a letter:

- F3 [A], F2 [B] and F2X [B1]: for forward-facing seats in group 1 (9 to 18 kg);
- R3 [C] and R2 [D]: rear-facing seats or shell seats in group 0+ (less than 13 kg) or group 1 (9 to 18 kg);
- R1 [E] rear-facing shell seats in group 0 (less than 10 kg) or 0+ (less than 13 kg);
- L1 [F] and L2 [G]: for carrycots in group 0 (less than 10 kg);
- B2: for booster seats in groups 2 and 3 (15 to 25 kg and 22 to 36 kg).

## CHILD SEATS: fitted using the ISOFIX SYSTEM (3/4)

### Visual installation of the five-seater version



59171



Using a child safety system which is not approved for this vehicle will not correctly protect the baby or child. They risk serious or even fatal injury.



Seat which does not allow a child seat to be fitted.

### Child seat fitted using the ISOFIX mounting



Seat which allows an ISOFIX child seat to be fitted.



The rear seats are fitted with an anchorage point which allows a forward-facing ISOFIX child seat with universal approval to be attached.



Check that your child is always strapped in and that the harness or seat belt is correctly adjusted: see the information on “Seat belts” in Section 1.

If necessary, adjust the seat position accordingly.

## CHILD SEATS: fitted using the ISOFIX SYSTEM (4/4)

### Visual installation of four-seater version



Using a child safety system which is not approved for this vehicle will not correctly protect the baby or child. They risk serious or even fatal injury.



Seat which does not allow a child seat to be fitted.



Carrying a passenger is STRICTLY PROHIBITED.

### Child seat fitted using the ISOFIX mounting



Seat which allows an ISOFIX child seat to be fitted.



The rear seats are fitted with an anchorage point which allows a forward-facing ISOFIX child seat with universal approval to be attached.



Check that your child is always strapped in and that the harness or seat belt is correctly adjusted: see the information on “Seat belts” in Section 1.

If necessary, adjust the seat position accordingly.

## CHILD SAFETY: deactivating, activating AIRBAG front passenger (1/3)

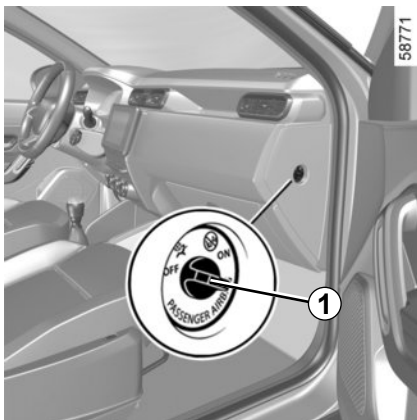

### Front passenger airbag deactivation

(depending on vehicle)

Before installing a child seat on the front passenger seat:

- check that the child seat can be installed on this seat;
- it is essential **to deactivate** the airbag for a rear-facing child seat.

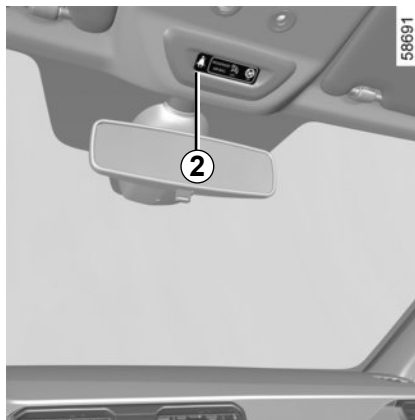

To deactivate the airbag: with the vehicle stationary and the ignition switched off, push and turn lock 1 to the **OFF** position.

When the ignition is switched on, it is **essential** to check that the warning

light  2 is illuminated on the display 2.

**This warning light remains continuously lit to let you know that you can fit a child seat.**



### DANGER

Since operation of the front passenger airbag is not compatible with the position of a rear-facing child seat, **NEVER** fit a rear-facing child restraint system in a seat protected by an **ACTIVATED** front **AIRBAG**. This can lead to the **DEATH** of the **CHILD** or **SERIOUS INJURY**.



the passenger airbag must be activated or deactivated only while the **vehicle is stationary** and the **ignition is off**.

If it is interfered with when the vehicle is being driven, indicator lights

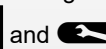

and  will come on.

Switch the ignition off then on again to reset the airbag in accordance with the lock position.

## CHILD SAFETY: deactivating, activating AIRBAG front passenger (2/3)

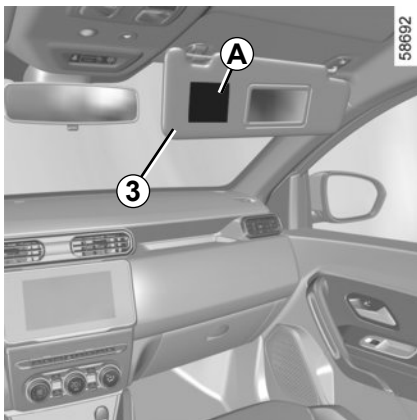

### DANGER

Since operation of the front passenger airbag is not compatible with the position of a rear-facing child seat, **NEVER** fit a rear-facing child restraint system in a seat protected by an **ACTIVATED** front **AIRBAG**. This can lead to the **DEATH** of the **CHILD** or **SERIOUS INJURY**.

58035

A



58034

B



The markings on the dashboard and the labels **A** or **B** (depending on the vehicle) on each side of the passenger sun visor **3** (see example of labels above) provide a reminder of these instructions.



## CHILD SAFETY: deactivating, activating AIRBAG front passenger (3/3)

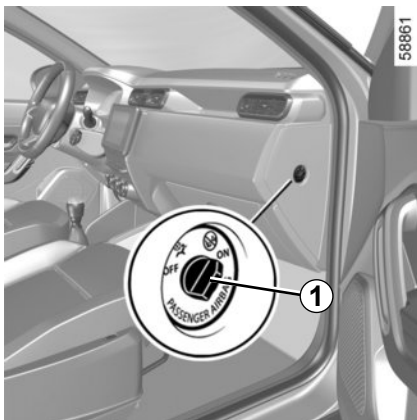

### Front passenger airbag activation

(depending on vehicle)

You should reactivate the airbag as soon as you remove the child seat from the front passenger seat to ensure the protection of the front passenger in the event of an impact.

**To reactivate the airbag: with the vehicle stationary and the ignition switched off, press and turn the lock 1 to the ON position.**

When the ignition is switched on, **you must check** that the warning light



is switched off on the display 2.

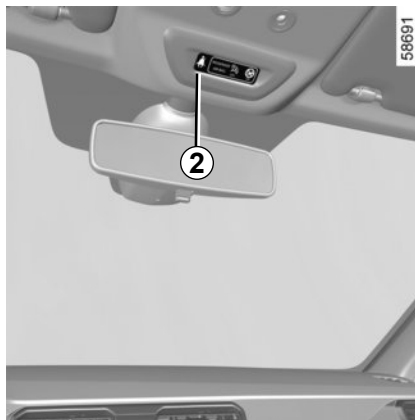

### Operating faults

It is forbidden to fit a rear-facing child seat to the front passenger seat if the airbag activation/deactivation system is faulty.

Allowing any other passenger to sit in that seat is not recommended.

Contact your approved dealer as soon as possible.



the passenger airbag must be activated or deactivated only while the **vehicle is stationary** and the **ignition is off**.

If it is interfered with when the vehicle is being driven, indicator lights



and  will come on.

Switch the ignition off then on again to reset the airbag in accordance with the lock position.

# DRIVER'S POSITION, LEFT-HAND DRIVE (1/12)

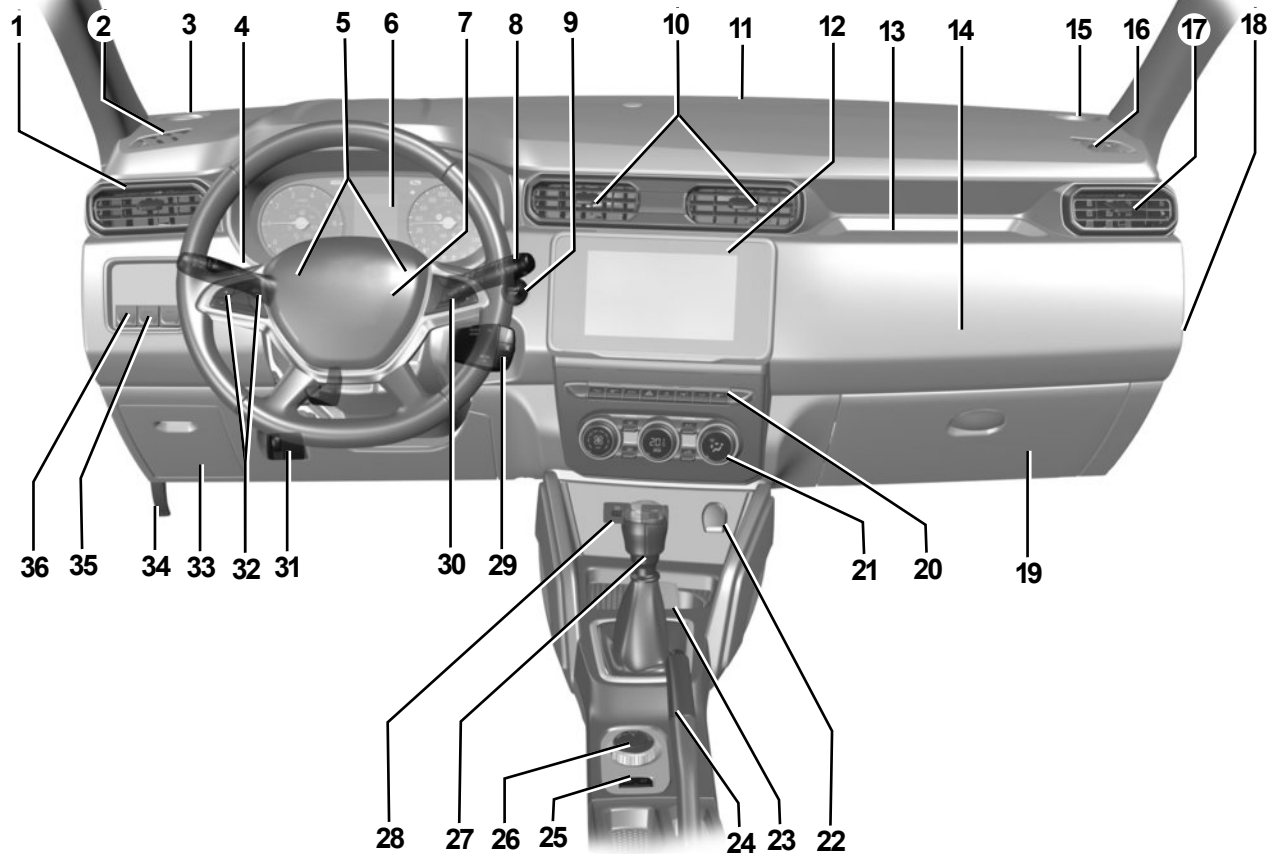

58774

## DRIVER'S POSITION, LEFT-HAND DRIVE (2/12)

The fittings described **DEPEND ON THE VEHICLE VERSION AND COUNTRY.**

**1** Side air vent.

**2** Side demister outlet.

**3** Tweeter.

**4** Stalk:

- direction indicator lights,
- exterior lights,
- front fog lights,
- rear fog light.

**5** Horn.

**6** Instrument panel.

**7** Driver airbag location.

**8** Steering column stalk for windscreen and rear screen wash/wiper.

**9** Start button.

**10** Centre air vents.

**11** Central demister outlet.

**12** Location for radio, navigation system or storage compartments.

**13** Dashboard upper storage compartment.

**14** Passenger airbag location.

**15** Tweeter.

**16** Side demister outlet.

**17** Side air vent.

**18** Passenger airbag activation/deactivation switch.

**19** Glove compartment.

**20** Main switch for:

- activation/deactivation of ESC version **4x4 (4WD)**,
- activating/deactivating the system camera in multiple view,
- activation/deactivation of the parking distance control,
- activation/deactivation of central door locking,
- activation/deactivation of the hazard warning lights,
- activation/deactivation of ECO, mode;
- activating/deactivating the **Stop and Start** function,
- activation/deactivation of the hill descent control function.

# DRIVER'S POSITION, LEFT-HAND DRIVE (3/12)

58774

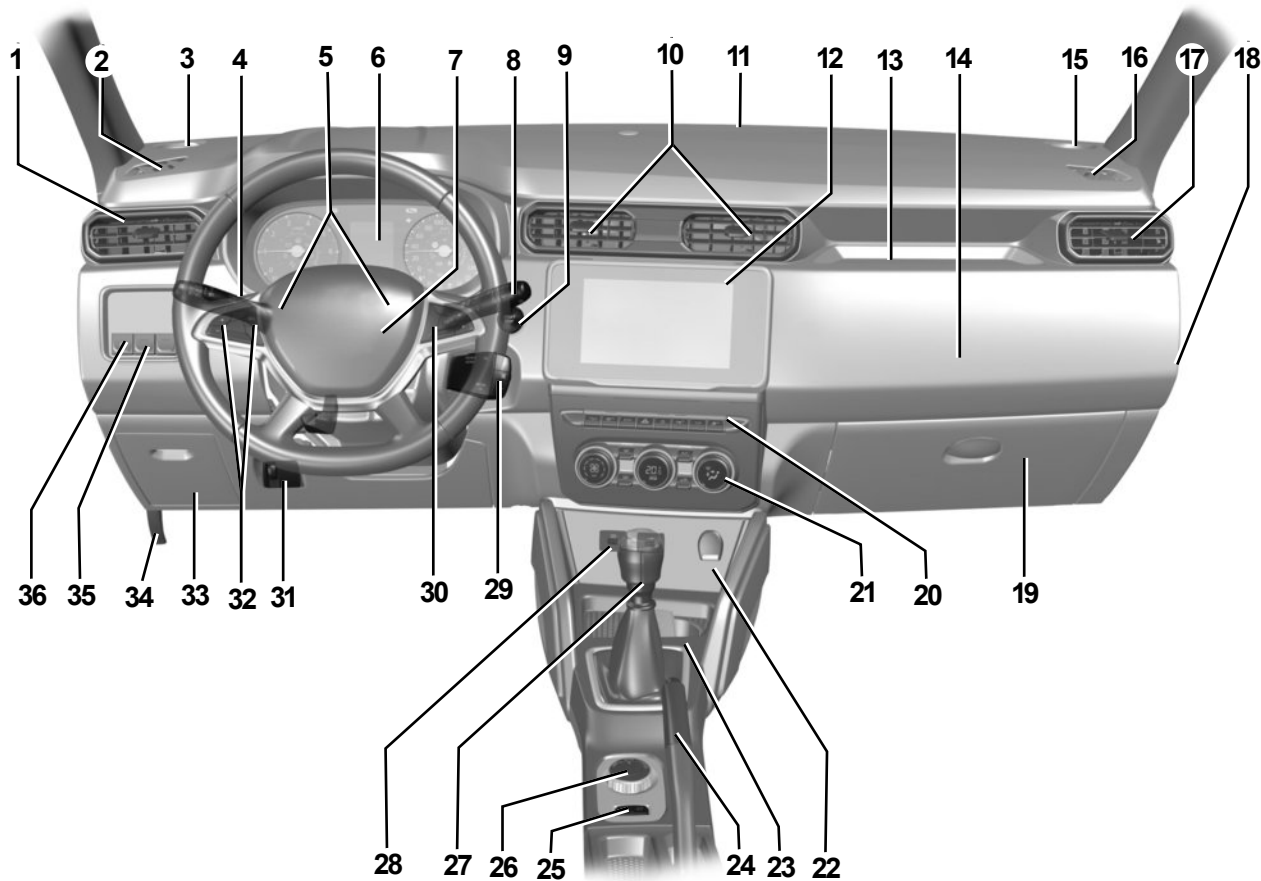

## DRIVER'S POSITION, LEFT-HAND DRIVE (4/12)

The fittings described **DEPEND ON THE VEHICLE VERSION AND COUNTRY.**

**21** Heating or air conditioning controls.

**22** Cigarette lighter or accessories socket.

**23** Bottle holders.

**24** Handbrake.

**25** Main switch for:

- speed limiter,
- cruise control.

**26** **4x2 (2WD)** and **4x4 (4WD)** mode selector.

**27** Gearstick.

**28** Multimedia sockets.

**29** Radio remote control.

**30** Control:

- trip computer and warning system information readout,
- multimedia system voice control.

**31** Beam height adjustment control.

**32** Function settings controls:

- speed limiter,
- cruise control.

**33** Fuse box.

**34** Bonnet release control.

**35** Activation/deactivation of the blind spot warning function.

**36** LPG control.

# DRIVER'S POSITION, LEFT-HAND DRIVE (5/12)

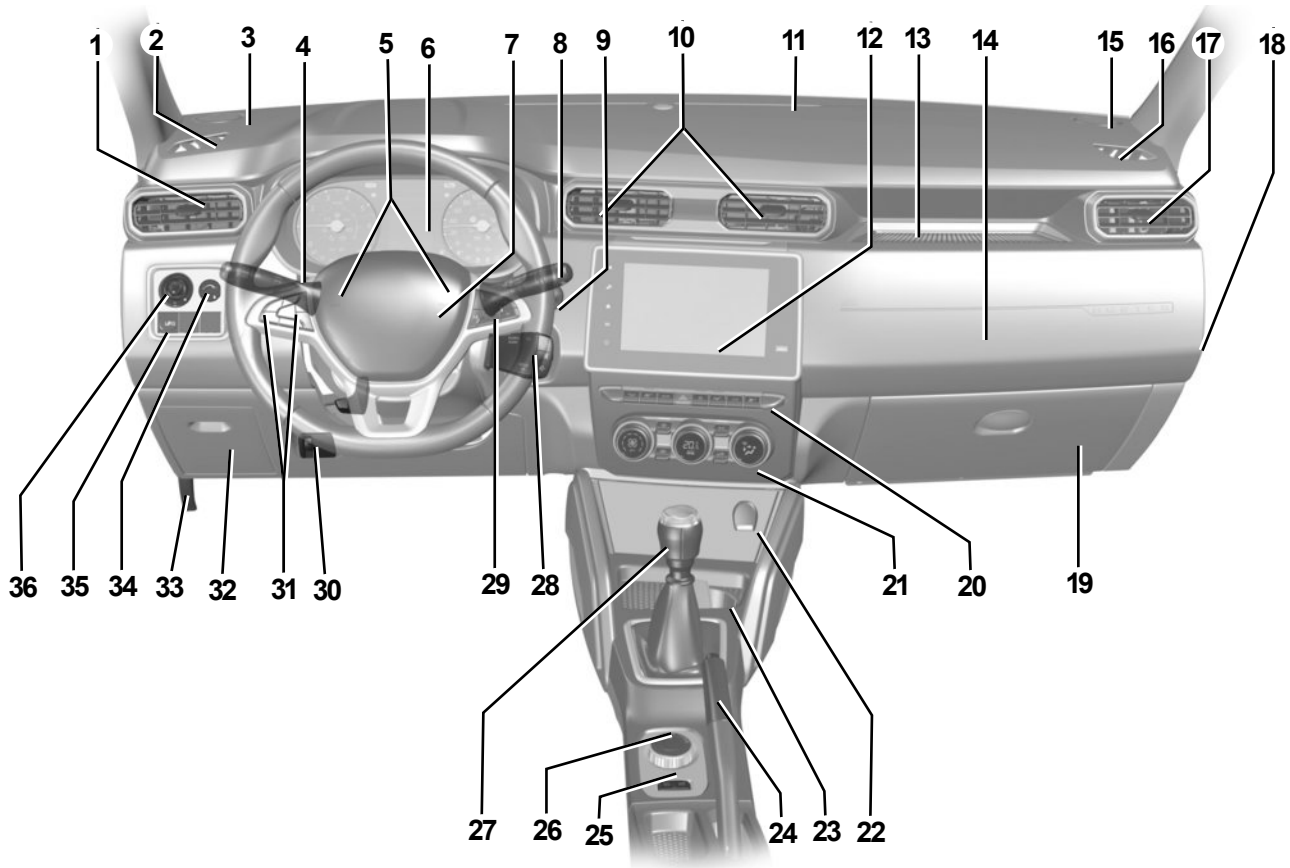

56474

## DRIVER'S POSITION, LEFT-HAND DRIVE (6/12)

The fittings described **DEPEND ON THE VEHICLE VERSION AND COUNTRY.**

**1** Side air vent.

**2** Side demister outlet.

**3** Tweeter.

**4** Stalk:

- direction indicator lights,
- exterior lights,
- front fog lights,
- rear fog light.

**5** Horn.

**6** Instrument panel.

**7** Driver airbag location.

**8** Steering column stalk for windscreen and rear screen wash/wiper.

**9** Start button.

**10** Centre air vents.

**11** Central demister outlet.

**12** Location for radio, navigation system or storage compartments.

**13** Dashboard upper storage compartment.

**14** Passenger airbag location.

**15** Tweeter.

**16** Side demister outlet.

**17** Side air vent.

**18** Passenger airbag activation/deactivation switch.

**19** Glove compartment.

**20** Main switch for:

- activation/deactivation of ESC version **4x4 (4WD)**,
- activating/deactivating the system camera in multiple view,
- activation/deactivation of the parking distance control,
- activation/deactivation of central door locking,
- activation/deactivation of the hazard warning lights,
- activation/deactivation of ECO, mode;
- activating/deactivating the **Stop and Start** function,
- activation/deactivation of the hill descent control function.

# DRIVER'S POSITION, LEFT-HAND DRIVE (7/12)

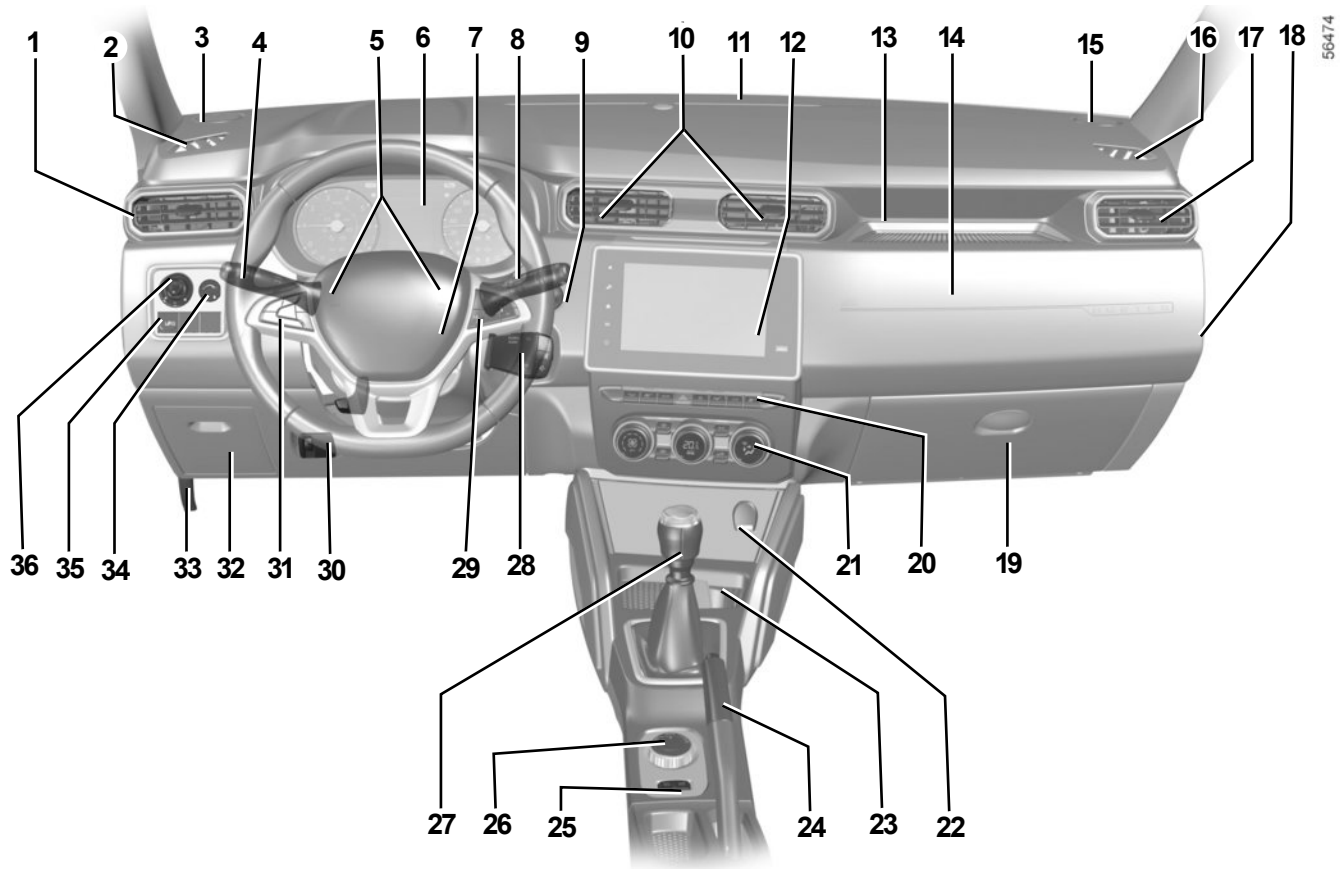

56474



## DRIVER'S POSITION, LEFT-HAND DRIVE (8/12)

The fittings described **DEPEND ON THE VEHICLE VERSION AND COUNTRY.**

**21** Heating or air conditioning controls.

**22** Cigarette lighter or accessories socket.

**23** Bottle holders.

**24** Handbrake.

**25** Main switch for:

- speed limiter,
- cruise control.

**26** 4x2 (2WD) and 4x4 (4WD) mode selector.

**27** Gearstick.

**28** Radio remote control.

**29** Control:

- trip computer and warning system information readout,
- multimedia system voice control.

**30** Beam height adjustment control.

**31** Function settings controls:

- speed limiter,
- cruise control.

**32** Fuse box.

**33** Bonnet release control.

**34** LPG control

**35** Activation/deactivation of the blind spot warning function.

**36** Exterior rear view mirror adjustment control.

# DRIVER'S POSITION, LEFT-HAND DRIVE (9/12)

53805

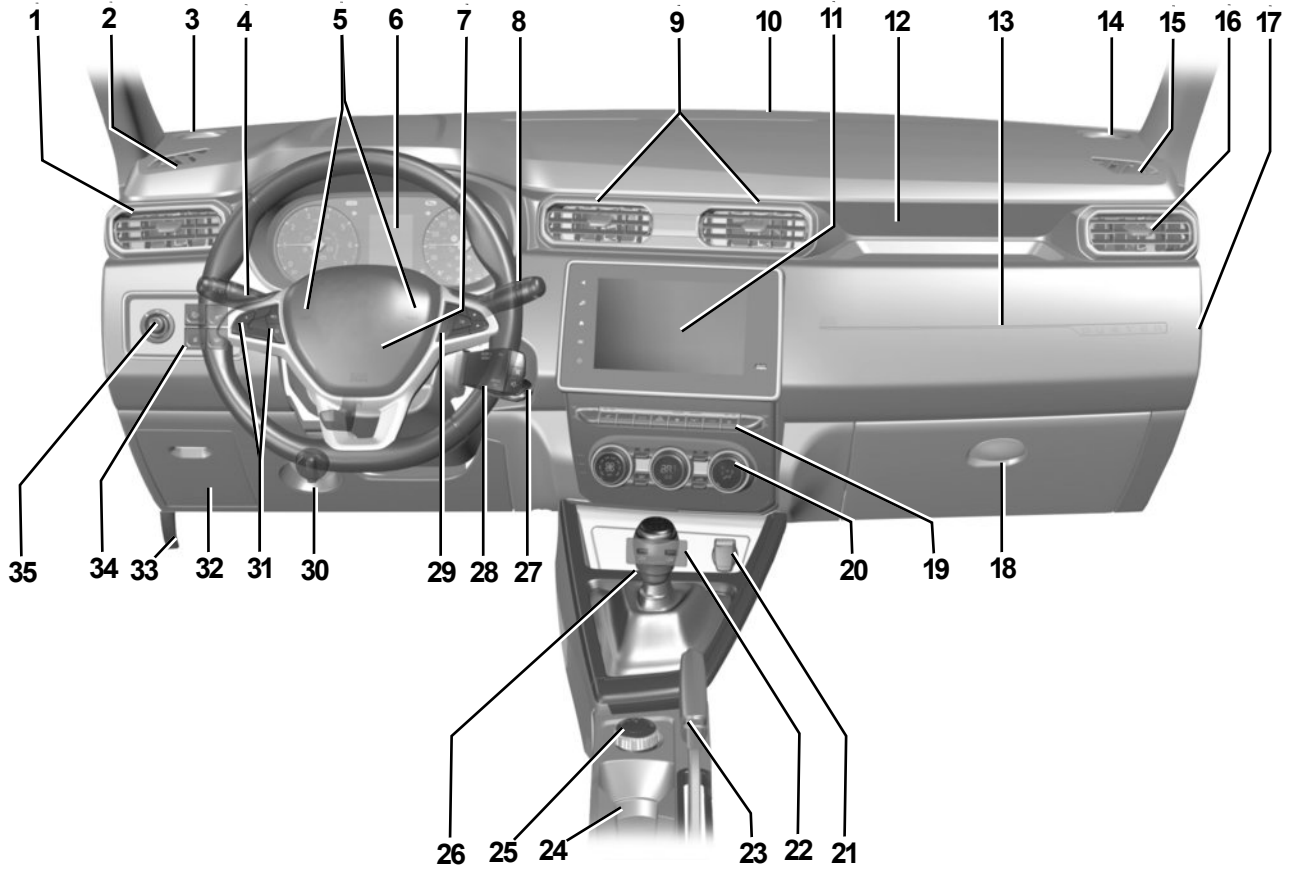

## DRIVER'S POSITION, LEFT-HAND DRIVE (10/12)

The fittings described **DEPEND ON THE VEHICLE VERSION AND COUNTRY.**

**1** Side air vent.

**2** Side demister outlet.

**3** Tweeter.

**4** Stalk:

- direction indicator lights,
- exterior lights,
- front fog lights,
- rear fog light.

**5** Horn.

**6** Instrument panel.

**7** Driver airbag location.

**8** Steering column stalk for windscreen and rear screen wash/wiper.

**9** Centre air vents.

**10** Central demister outlet.

**11** Location for radio, navigation system or storage compartments.

**12** Dashboard upper storage compartment.

**13** Passenger airbag location.

**14** Tweeter.

**15** Side demister outlet.

**16** Side air vent.

**17** Passenger airbag activation or deactivation switch.

**18** Glove compartment

**19** Main switch for:

- activation/deactivation of the heated front seats,
- activation/deactivation of ECO mode,
- activation/deactivation of the hazard warning lights,
- activation/deactivation of central door locking,
- activation/deactivation of the parking distance control,
- activating/deactivating the multi-view camera system.

# DRIVER'S POSITION, LEFT-HAND DRIVE (11/12)

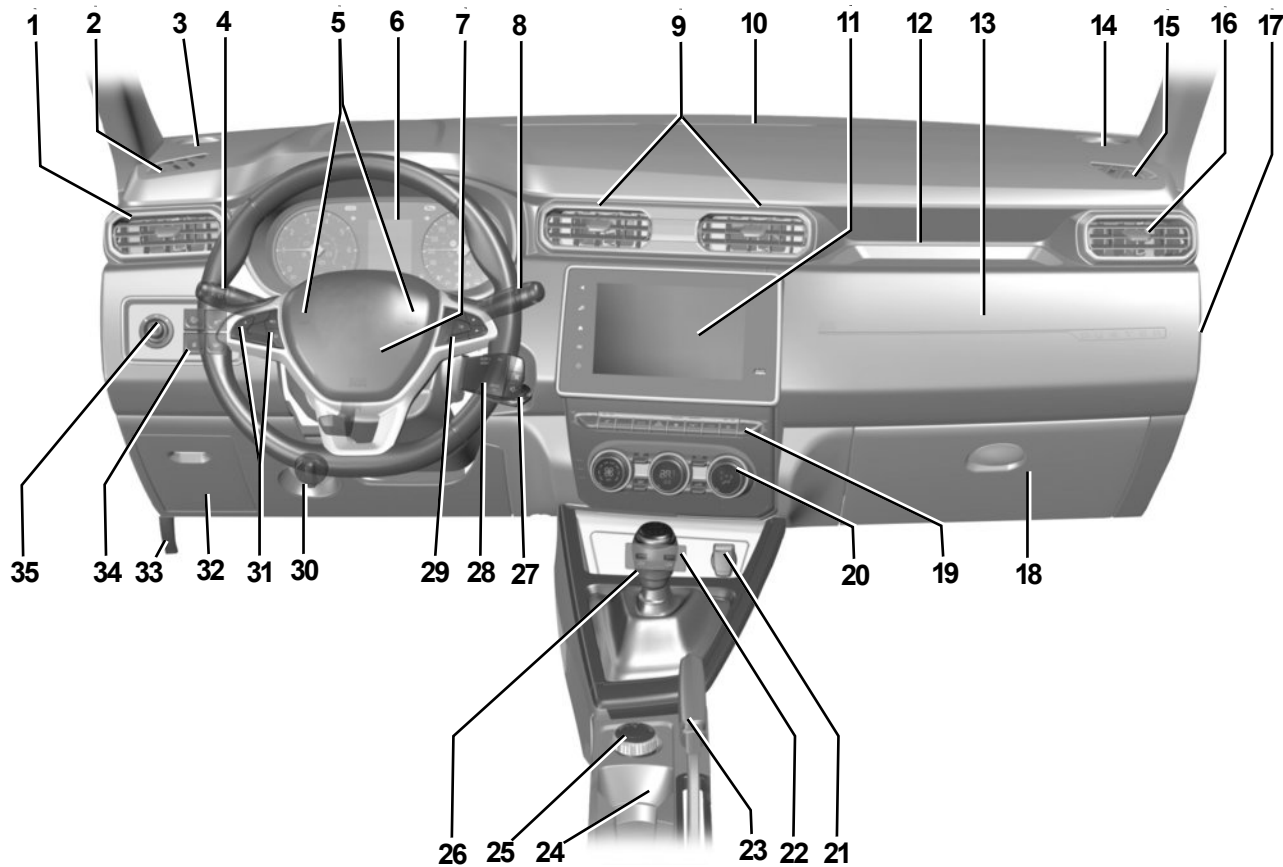

53805

## DRIVER'S POSITION, LEFT-HAND DRIVE (12/12)

The fittings described **DEPEND ON THE VEHICLE VERSION AND COUNTRY.**

**20** Heating or air conditioning controls.

**21** Cigarette lighter or accessories socket.

**22** Multimedia sockets.

**23** Handbrake.

**24** Bottle holders.

**25 4x2 (2WD)** and **4x4 (4WD)** mode selector.

**26** Gearstick.

**27** Ignition switch.

**28** Radio remote control.

**29** Control:

- trip computer and warning system information readout,
- multimedia system voice control.

**30** Beam height adjustment control.

**31** Cruise control/speed limiter controls and main switch.

**32** Fuse box.

**33** Bonnet release control.

**34** Switch:

- activation/deactivation of the Hill Descent Control function,
- activation/deactivation of ESC,
- activation/deactivation of the steering wheel heating,
- activation/deactivation of the electric heated windscreen function.

**35** Exterior rear view mirror adjustment control.

# DRIVING POSITION, RIGHT-HAND DRIVE (1/4)

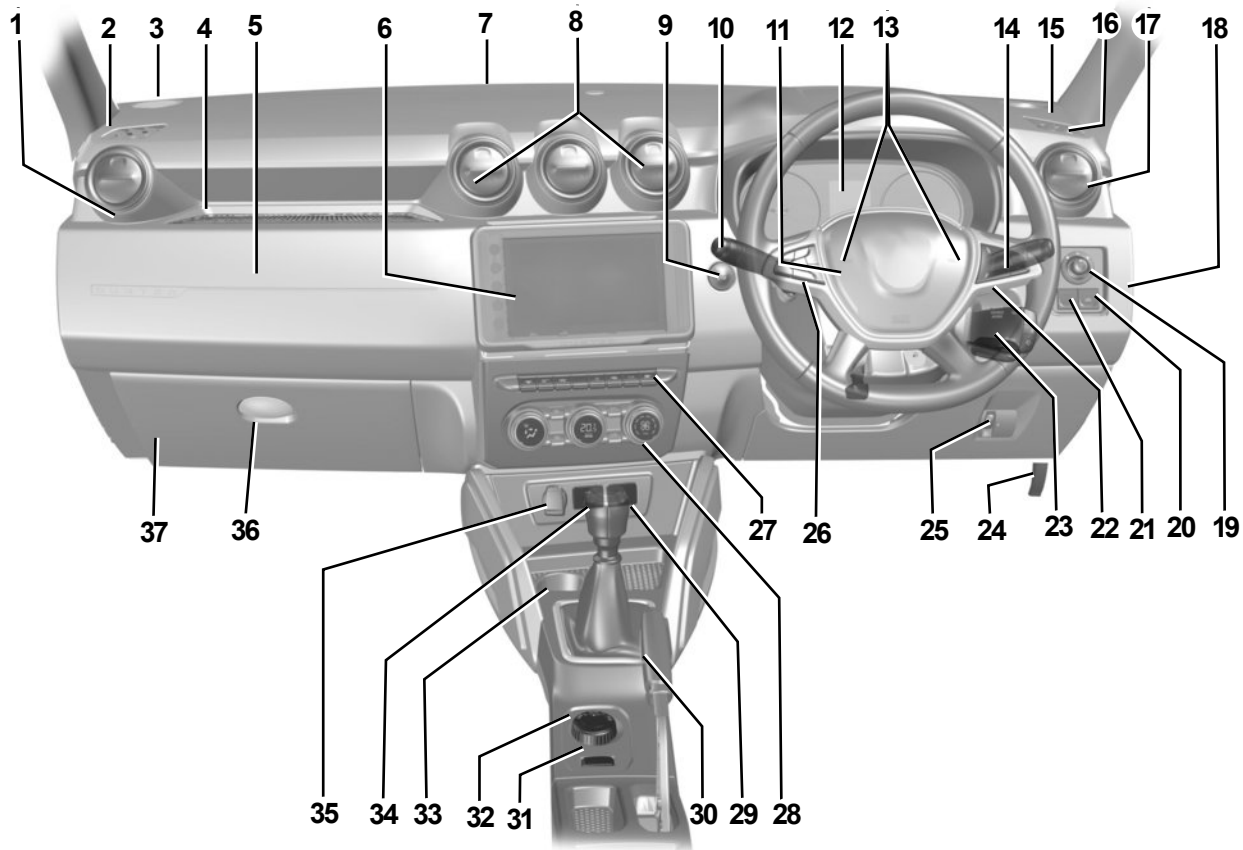

56226

## DRIVING POSITION, RIGHT-HAND DRIVE (2/4)

The presence of the equipment **DEPENDS ON THE VEHICLE VERSION AND COUNTRY.**

**1** Side air vent.

**2** Side demister outlet.

**3** Tweeter.

**4** Dashboard upper storage compartment.

**5** Passenger airbag location.

**6** Location for radio, navigation system or storage compartments.

**7** Central demister outlet.

**8** Centre air vents.

**9** Start button.

**10** Stalk:

- direction indicator lights,
- exterior lights,
- front fog lights,
- rear fog light.

**11** Driver airbag location.

**12** Instrument panel.

**13** Horn.

**14** Steering column stalk for windscreen and rear screen wash/wiper.

**15** Tweeter.

**16** Side demister outlet.

**17** Side air vent.

**18** Passenger airbag activation/deactivation switch.

**19** Exterior rear view mirror adjustment control.

**20** LPG control

**21** Activation/deactivation of the blind spot warning function.

**22** Control:

- trip computer and warning system information readout,
- multimedia system voice control.

**23** Radio remote control.

**24** Bonnet release control.

**25** Beam height adjustment control.

**26** Function settings controls:

- speed limiter,
- cruise control.

# DRIVING POSITION, RIGHT-HAND DRIVE (3/4)

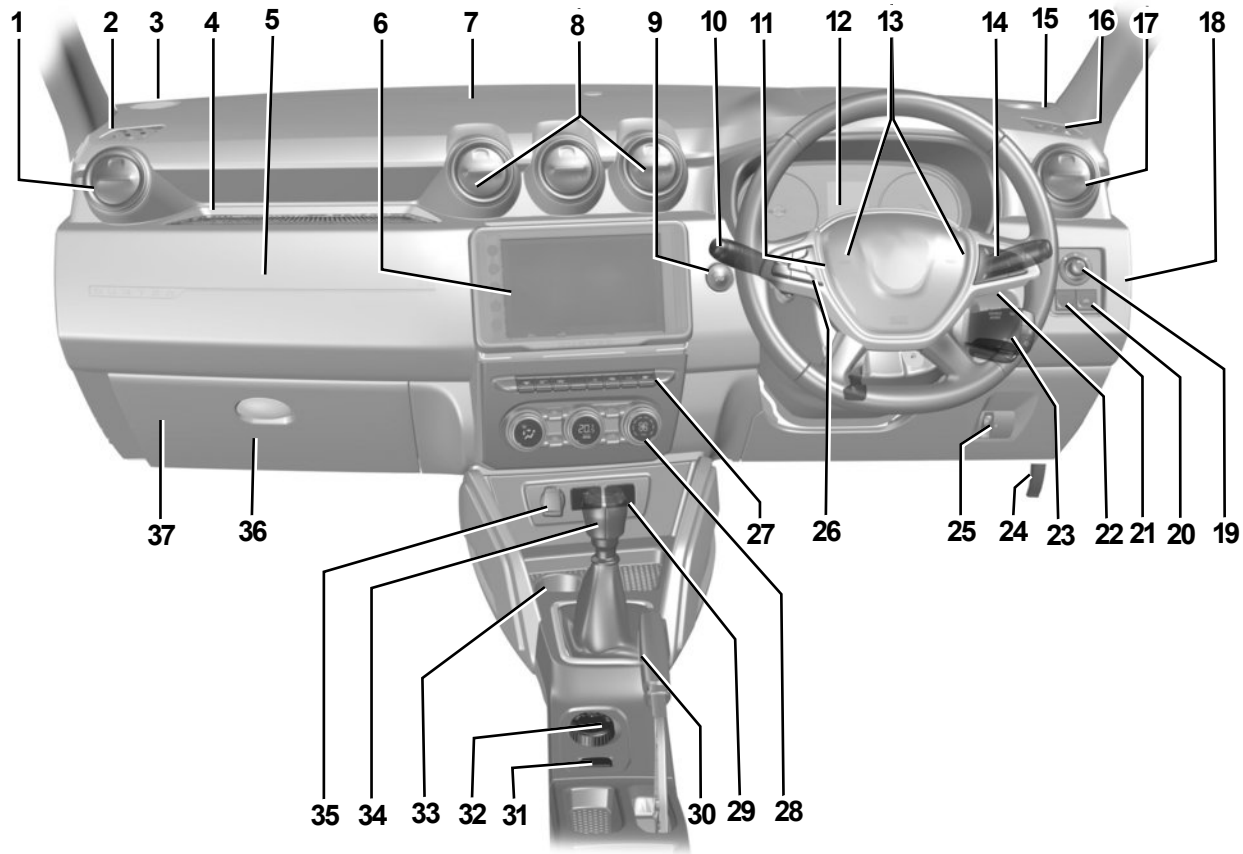

56226



## DRIVING POSITION, RIGHT-HAND DRIVE (4/4)

The presence of the equipment **DEPENDS ON THE VEHICLE VERSION AND COUNTRY.**

**27** Main switch for:

- activation/deactivation of ESC version **4x4 (4WD)**,
- activating/deactivating the system camera in multiple view,
- activation/deactivation of the parking distance control,
- activation/deactivation of central door locking,
- activation/deactivation of the hazard warning lights,
- activation/deactivation of ECO mode,
- activating/deactivating the **Stop and Start** function,
- activation/deactivation of the hill descent control function.

**28** Heating or air conditioning controls.

**29** Multimedia sockets.

**30** Handbrake.

**31** Main switch for:

- speed limiter,
- cruise control.

**32** **4x2 (2WD)** and **4x4 (4WD)** mode selector.

**33** Bottle holders.

**34** Gearstick.

**35** Cigarette lighter or accessories socket.

**36** Glovebox.

**37** Fuse box.

## WARNING LIGHTS (1/6)

The presence and operation of the warning lights **DEPEND ON THE EQUIPMENT AND COUNTRY.**



**Instrument panel A**



If no lights or sounds are apparent, this indicates a fault in the instrument panel. This indicates that it is essential to stop immediately (as soon as traffic conditions allow). Ensure that the vehicle is correctly immobilised and contact an approved Dealer.



Warning light **STOP** requires you to stop immediately, for your own safety, as soon as traffic conditions allow. Switch off the engine and do not restart it. Contact an approved Dealer.

The  warning light means you should **drive very carefully** to an approved dealer as soon as possible. If you fail to follow this recommendation, you risk damaging your vehicle.

## WARNING LIGHTS (2/6)

The presence and operation of the warning lights **DEPEND ON THE EQUIPMENT AND COUNTRY.**



### Brake circuit fault warning light

It lights up when the ignition or the engine is switched on and goes off after a few seconds.

If it comes on during braking and is accompanied by the **STOP** warning light and a beep, it indicates that the fluid level in the circuit is low or that there is a braking system fault. Stop as soon as traffic conditions allow and contact an authorised dealer.

### Urgent stop warning light (red)

This lights up when the ignition is switched on and goes out as soon as the engine is started. It lights up at the same time as other warning lights, and is accompanied by a beep.

It requires you to stop immediately, for your own safety, as soon as traffic conditions allow. Switch off the engine and do not restart it.

Contact an approved Dealer.

### Warning light (orange)

This lights up when the ignition is switched on and goes out as soon as the engine is started. It may come on in conjunction with other warning lights on the instrument panel.

It means you should **drive very carefully** to an authorised dealer as soon as possible. If you fail to follow this recommendation, you risk damaging your vehicle.

### Coolant temperature warning light

This lights up blue when you switch on the ignition or start the engine.

If it turns red, stop and let the engine idle for a minute or two.

The temperature should drop and the warning light should switch off or turn blue again. Otherwise, stop the engine. Let the engine cool down before checking the coolant.

Contact an approved Dealer.

### Brake pedal warning light

This lights up when the brake pedal should be depressed.

## WARNING LIGHTS (3/6)

The presence and operation of the warning lights **DEPEND ON THE EQUIPMENT AND COUNTRY.**



### Oil pressure warning light

This lights up when the ignition is switched on and goes out after a few seconds.

If it comes on on the road, accompanied by the **STOP** warning light and a beep, stop immediately and cut the ignition.

Check the oil level (refer to “Engine oil level: general information” in Section 4). If the level is normal, the light has come on for another reason: Consult an authorised dealer straight away.



### Preheating warning light (diesel version)

This should come on when the ignition is switched on. It indicates that the heater plugs are in operation. It goes out after preheating is sufficient and the engine can be started.



### Indicator light

This lights up when the ignition is switched on and goes out after a few seconds. If it does not light up when the ignition is switched on, if it lights up when the engine is running, or if it flashes, it indicates a fault in the system.

Contact an approved Dealer as soon as possible.



### Low fuel level warning light

It lights up orange when the ignition or the engine is switched on then, depending on the vehicle, goes off after a few seconds or is displayed in white. If it comes on orange while driving and is accompanied by a beep, fill up with fuel as soon as possible. There is only approximately 31 miles (50 km) worth of fuel left.



### Anti-lock braking warning light

This lights up when the ignition is switched on and goes out after a few seconds.

If it does not go out after the ignition is switched on, or lights up when driving, there is a fault with the ABS. Braking will then be as normal, without the ABS. Contact an approved Dealer as soon as possible.



### Warning light for reagent level and faults in the exhaust gas reduction system

Refer to the information on “Reagent tank” in Section 1.



### Gear change indicator

This lights up to advise you to change to a higher gear (up arrow) or lower gear (down arrow).

## WARNING LIGHTS (4/6)

The presence and operation of the warning lights **DEPEND ON THE EQUIPMENT AND COUNTRY.**



### **Battery charge warning light**

It lights up when the ignition or the engine is switched on and goes off after a few seconds.

If it comes on on the road, accompanied by the **STOP** warning light and a beep, this indicates an overload or discharge in the electrical circuit.

Stop as soon as traffic conditions allow and contact an approved Dealer.

### **Warning light for the electronic stability program (ESC) and traction control system**

This lights up when the ignition is switched on and goes out after a few seconds.

There are several reasons for the warning light to come on: refer to the paragraph “Electronic stability program ESC with understeer control and traction control” in Section 2.

### **Indicator light ESC OFF**

Refer to the information on “Driving correction devices and aids” in Section 2.

### **Door(s) open warning light**

Refer to “Opening/closing the doors” in Section 1.

### **Cruise control warning lights**

Refer to the information on “Cruise control” in Section 2.

### **Speed limiter warning light**

Refer to the information on the “Speed limiter” in Section 2.

### **Excess speed warning light**

A beep will sound and the warning light will come on if the vehicle exceeds 70 mph (120 km/h).

### **Hill Descent Control indicator light**

Refer to information on “Driver correction devices and aids” in Section 2.

### **Engine standby warning light**

Please see information in the paragraph on “Stop and Start Function” in Section 2.

### **Unavailability of engine standby warning light**

Please see information in the paragraph on “Stop and Start Function” in Section 2.

## WARNING LIGHTS (5/6)

The presence and operation of the warning lights **DEPEND ON THE EQUIPMENT AND COUNTRY.**



**Side light warning light**



**Main beam headlight tell-tale light**



**Dipped beam headlight tell-tale**



**Front fog light tell-tale light**



**Rear fog light tell-tale**



**Left-hand direction indicator tell-tale**



**Right-hand direction indicator tell-tale**



**Toxic Fume Filter System Warning Light**

On vehicles which are equipped with it, this light comes on when the engine is started and, depending on the vehicle, when the ignition is switched off if the vehicle is in the engine standby phase (refer to the information on the “Stop and Start function” in Section 2) then goes out.

- If it lights up continuously, consult your approved dealer as soon as possible;
- if it flashes, reduce the engine speed until the light stops flashing. Contact your approved Dealer as soon as possible.

Refer to the information on “Advice: antipollution, fuel economy and driving” in Section 2.



**Variable power-assisted steering warning light**

It lights up when the ignition or the engine is switched on and goes off after a few seconds.

It may also light up during battery troubleshooting: refer to the information on “Steering wheel, Power-assisted steering” in Section 1.

If it comes on while driving, alongside the warning light **STOP**, this means there is a system fault.

Contact an authorised dealer.



**Particle filter system warning light**

Please refer to the information on “Special features of petrol versions” and “Special features of diesel versions” in section 2.

## WARNING LIGHTS (6/6)

The presence and operation of the warning lights **DEPEND ON THE EQUIPMENT AND COUNTRY.**

### **ECO** Mode warning light ECO

This comes on when ECO mode is activated.

Please refer to the information on “Driving advice, Eco-driving” in Section 2.

### **4WD LOCK** 4-wheel drive mode indicator light

Refer to the information on “4WD Lock mode” in Section 2.

### **2WD** 2-wheel drive mode indicator light

Refer to the information on “2WD mode” in Section 2.

### **(P)** Problem applying handbrake

Please refer to “Handbrake” section in Section 2.

### **(!)** Tyre pressure loss warning

Please refer to the information on the “Tyre pressure loss warning” in Section 2.



#### **On display B**



#### **Passenger Airbag ON**

Refer to the information on “Child safety: deactivating/activating the front passenger airbag” in Section 1.



#### **Passenger Airbag OFF**

Refer to the information on “Child safety: deactivating/activating the front passenger airbag” in Section 1).



#### **Driver's seat belt reminder and, depending on the vehicle, front passenger seat belt reminder**

This lights up when the ignition is switched on, then, if the driver's or front passenger's (if this seat is occupied) seat belt is not fastened and the vehicle has reached approximately 12.4 mph (20 km/h), it flashes and a beep sounds for around 2 minutes.

**Note:** an object placed on the passenger seat base can activate the warning light.

## DISPLAYS AND INDICATORS (1/2)

43584

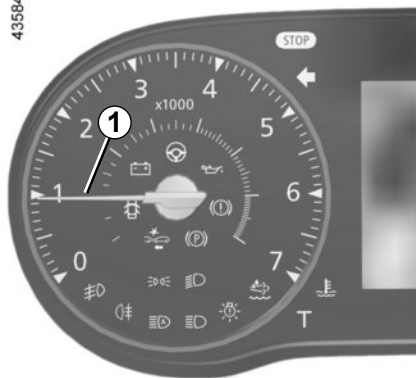

**Rev counter 1 (rpm x 1000)**

43590

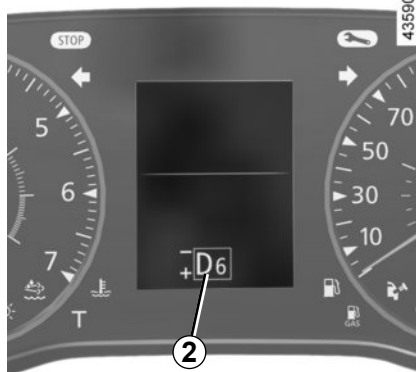

**Automatic gearbox display 2**

This indicates the gear engaged. Refer to information on the “Automatic gearbox” in Section 2.

53880



**Speedometer 3 and, depending on the vehicle, 4 (km or miles per hour)**

Control your speed according to the approved speedometer only 3.

The indicator 4 is provided as an indication.



## DISPLAYS AND INDICATORS (2/2)

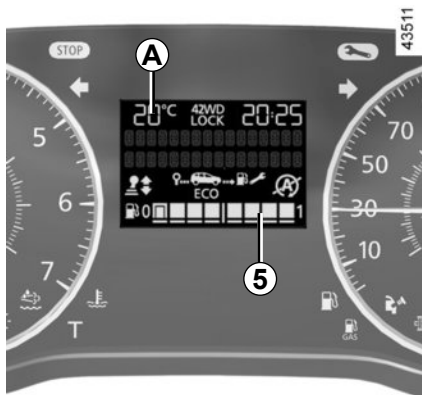

### Fuel gauge warning light 5 or 6

The number of squares lit shows the fuel level. When it is at minimum, the squares disappear and the low fuel level warning light comes on, depending on the vehicle.

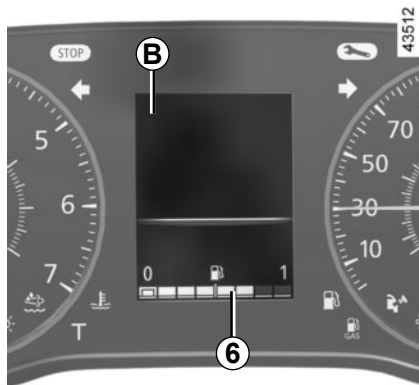

### Trip computer and warning system A or B

Refer to the information on the “Trip computer and warning system” in Section 1.

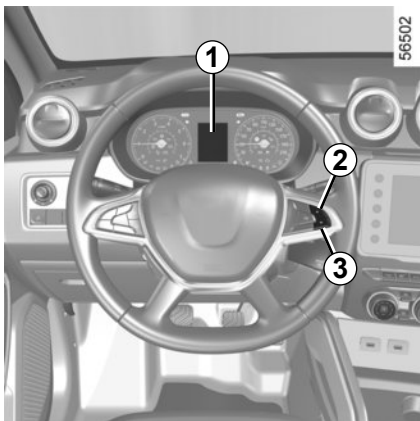

In **4x4 (4WD)** mode on rough terrain, there is a risk that incorrect information on the fuel level may be displayed. Wait until you are on flat ground again for a stable reading of the oil level squares.

## ON-BOARD COMPUTER: general information (1/2)



### Trip computer and warning system 1

Depending on the vehicle, this includes the following functions:

- distance travelled;
- journey parameters;
- information messages;
- operating fault messages (associated with the  warning light);
- warning messages (associated with the  warning light);

All these functions are described on the following pages.

### Display selection keys 2 or 3

Scroll through the following information by repeated short presses on button **2** or **3** (the display depends on the vehicle equipment and country):

- a) total mileage and trip mileage recorder;
- b) journey parameters:
  - average fuel consumption;
  - current fuel consumption;
  - estimated range with remaining fuel;
  - distance travelled;
  - average speed;
  - LPG average fuel consumption;
  - estimated range with remaining LPG fuel;
  - LPG range;
- c) current speed;
- d) distance before service;
- e) tyre pressure reset;
- f) trip log, operating faults and information message readout;

- g) estimated range with remaining reagent;
- h) engine coolant temperature;
- i) clock and exterior temperature;
- j) general adjustment.

## ON-BOARD COMPUTER: general information (2/2)

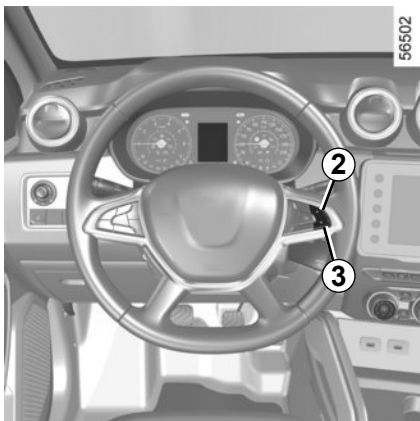

### Trip mileage resetting

With 'trip mileage recorder' selected on the display, press on button **2** or **3** until the mileage recorder resets to zero.

### Resetting the journey parameters (reset button)

With one of the journey parameters selected on the display, press button **2** or **3** until the display resets.

### Interpreting some of the values displayed after resetting

The values showing average fuel consumption and average speed will become more stable and reliable the further you have travelled since the last time the Reset button was pressed.

The average fuel consumption may decrease when:

- the vehicle stops accelerating;
- the engine reaches its operating temperature (if the engine was cold when the reset key was pressed);
- when driving from an urban area onto the open road.

### Special features of LPG versions



To access the information and reset the LPG trip parameters (refer to the following pages), please switch to LPG mode. Refer to the "Special features of LPG versions" paragraph in Section 2.

### Automatic resetting of the journey parameters

Resetting occurs automatically when the maximum value of any of the parameters is exceeded.

## TRIP COMPUTER: journey parameters (1/8)

The display of information shown below **DEPENDS ON THE VEHICLE EQUIPMENT AND COUNTRY.**

Examples of selections	Interpreting the display selected
<p>101778 km 112.4 km</p>	<p>⇒ a) <b>Total mileage and trip mileage recorder.</b></p>
<p>Average</p> <p> 5.8 L/100</p>	<p>⇒ b) <b>Journey parameters:</b> <b>Average fuel consumption.</b> The value is displayed after having travelled at least 400 metres since the last reset.</p>
<p>Current</p> <p> 7.4 L/100</p>	<p>⇒ <b>Current fuel consumption.</b> Value displayed after reaching a speed of 12 mph (20 km/h), depending on the vehicle.</p>

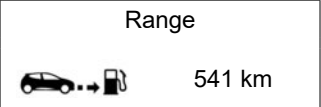
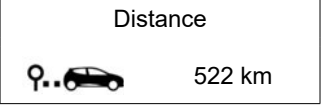
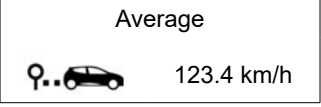

## TRIP COMPUTER: journey parameters (2/8)

The display of information shown below **DEPENDS ON THE VEHICLE EQUIPMENT AND COUNTRY.**

Examples of selections	Interpreting the display selected
<p data-bbox="216 303 288 328">Range</p> 	<p data-bbox="550 306 954 331"><b>b) Journey parameters (continued):</b></p> <p data-bbox="579 344 999 369"><b>Estimated range with remaining fuel.</b></p> <p data-bbox="579 370 1079 395">The value is displayed after driving 400 metres.</p>
<p data-bbox="205 463 299 488">Distance</p> 	<p data-bbox="579 496 958 520"><b>Distance travelled</b> since last reset.</p>
<p data-bbox="205 620 299 645">Average</p> 	<p data-bbox="579 639 964 664"><b>Average speed</b> since the last reset.</p> <p data-bbox="579 665 1079 689">The value is displayed after driving 400 metres.</p>

## TRIP COMPUTER: journey parameters (3/8)

The display of information shown below **DEPENDS ON THE VEHICLE EQUIPMENT AND COUNTRY.**

Examples of selections	Interpreting the display selected
<p>Average LPG</p>  --- L/100	<p>⇒ <b>b) Trip parameters (continued):</b> <b>Average LPG fuel consumption</b></p>
<p>Range LPG</p>  --- km	<p>⇒ <b>Estimated range with remaining LPG fuel.</b></p>
<p>Distance LPG</p>  --- km	<p>⇒ <b>Distance travelled on LPG fuel since the last reset.</b></p>
<p>55.8 mph (90 km/h)</p>	<p>⇒ <b>c) Current speed</b> (depending on the vehicle).</p>

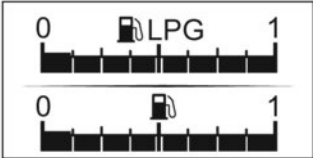
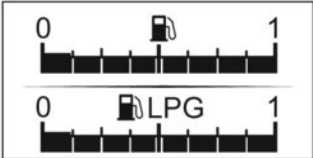

# TRIP COMPUTER: journey parameters (4/8)

The display of information shown below **DEPENDS ON THE VEHICLE EQUIPMENT AND COUNTRY.**

Examples of selections	Interpreting the display selected
	<p>⇒ <b>Petrol mode.</b></p>
	<p>⇒ <b>LPG mode.</b></p>

## TRIP COMPUTER: journey parameters (5/8)

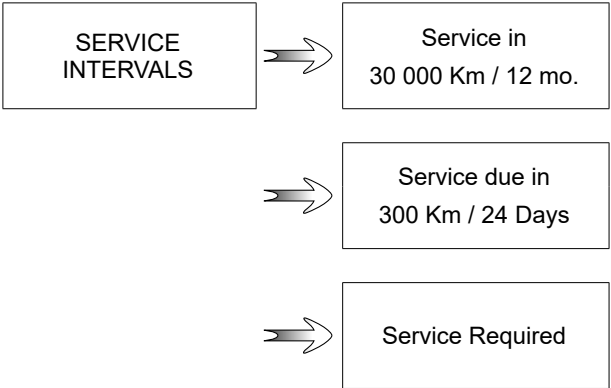
The display of information shown below **DEPENDS ON THE VEHICLE EQUIPMENT AND COUNTRY.**

Examples of selections	Interpreting the display selected
On-board computer with mileage-before-service message	
 <p>The diagram shows a box labeled "SERVICE INTERVALS" on the left. Three arrows point from this box to three separate boxes on the right. The first box contains "Service in 30 000 Km / 12 mo.". The second box contains "Service due in 300 Km / 24 Days". The third box contains "Service Required".</p>	<p><b>d) Mileage before service.</b> <b>With the ignition switched on, the engine not running</b> and the display set to "SERVICE INTERVALS", press button <b>3</b> or <b>4</b> for approximately 5 seconds to display the mileage before service (distance or time to the next service). When the distance value approaches its limit, there are several possible scenarios:</p> <ul style="list-style-type: none"><li>– range less than <b>930 miles (1,500 km)</b> or <b>one month</b>: the message "Service due in" is displayed accompanied by the nearest term (distance or time);</li><li>– range equal to <b>0 miles (0 km)</b> or <b>date of service reached</b>: the message "Service Required" is displayed accompanied by the warning light .</li></ul> <p>The vehicle requires a service as soon as possible.</p>
<p><b>Reset:</b> to reset the distance before the next service, press and hold button <b>2</b> or <b>3</b> for approximately 10 seconds until the display shows the mileage before service permanently.</p> <p><b>Note:</b> if a service is performed without changing the engine oil, only the mileage before the next service should be reset. In the event of an oil change, both the distance before the next service and the next oil change should be reset.</p>	





## TRIP COMPUTER: journey parameters (6/8)

The display of information shown below **DEPENDS ON THE VEHICLE EQUIPMENT AND COUNTRY.**

Examples of selections	Interpreting the display selected									
On-board computer with distance before next service message (cntd.)										
<table border="0"><tr><td data-bbox="87 300 344 406" style="text-align: center;">SERVICE INTERVALS</td><td data-bbox="344 300 423 406" style="text-align: center;">➡</td><td data-bbox="423 300 692 406" style="text-align: center;">Oil change in 30 000 Km / 12 mo.</td></tr><tr><td></td><td data-bbox="344 440 423 546" style="text-align: center;">➡</td><td data-bbox="423 440 692 546" style="text-align: center;">Service due in 300 Km / 24 Days</td></tr><tr><td></td><td data-bbox="344 580 423 686" style="text-align: center;">➡</td><td data-bbox="423 580 692 686" style="text-align: center;">Service Required</td></tr></table>	SERVICE INTERVALS	➡	Oil change in 30 000 Km / 12 mo.		➡	Service due in 300 Km / 24 Days		➡	Service Required	<p><b>d) Mileage before service</b> <b>With the ignition on, the engine not running</b> and the display showing “SERVICE INTERVALS”, press button <b>3</b> or <b>4</b> for about 5 seconds to display the mileage before the next service, then press button <b>2</b> to view the mileage before the next oil change (distance or time remaining before the next service). When the distance value approaches its limit, there are several possible scenarios:</p> <ul style="list-style-type: none"><li>– range less than <b>930 miles (1,500 km)</b> or <b>one month</b>: the message “Service due in” is displayed accompanied by the nearest term (distance or time);</li><li>– range equal to <b>0 miles (0 km)</b> or <b>date of oil change reached</b>: the message “Service Required” is displayed accompanied by the warning light .</li></ul> <p>The vehicle requires an oil change as soon as possible.</p>
SERVICE INTERVALS	➡	Oil change in 30 000 Km / 12 mo.								
	➡	Service due in 300 Km / 24 Days								
	➡	Service Required								
<p>Depending on the vehicle, the mileage before an oil change varies according to the driving style (frequent driving at low speed, door-to-door journeys, extensive use at idling speed, towing a trailer, etc.). The distance remaining until the next oil change can therefore decrease more quickly in some cases than the actual distance travelled.</p> <p><b>Reset:</b> to reset the distance before the next service, press and hold button <b>2</b> or <b>3</b> for approximately 10 seconds until the display shows the mileage before oil change permanently.</p> <p><b>NB:</b> if a service is performed without changing the engine oil, only the mileage before the next service should be reset. In the event of an oil change, both the distance before the next service and the next oil change should be reset.</p>										



## TRIP COMPUTER: journey parameters (7/8)

The display of information shown below **DEPENDS ON THE VEHICLE EQUIPMENT AND COUNTRY.**

Examples of selections	Interpreting the display selected
<div data-bbox="276 288 545 449" style="border: 1px solid black; padding: 10px; margin-bottom: 20px;">Check tyre press and init.</div> <div data-bbox="276 510 545 678" style="border: 1px solid black; padding: 10px; margin-bottom: 20px;">No message memorised</div> <div data-bbox="276 810 545 984" style="border: 1px solid black; padding: 10px;">Top Up AdBlue before 2400 km</div>	<p data-bbox="787 333 858 367"></p> <p data-bbox="886 306 1188 329"><b>e) Reset the tyre pressure.</b></p> <p data-bbox="916 344 1433 394">Please refer to the information on the “Tyre pressure loss warning” in Section 2.</p> <p data-bbox="787 580 858 613"></p> <p data-bbox="886 530 1006 553"><b>f) Trip log.</b></p> <p data-bbox="916 568 1124 591">Successive display:</p> <ul data-bbox="916 607 1433 723" style="list-style-type: none"><li data-bbox="916 607 1433 656">– information messages (ESC deactivated/activated, STOP and START activated etc.);</li><li data-bbox="916 672 1433 723">– operating fault messages (check the injection system, airbag etc.).</li></ul> <p data-bbox="787 893 858 927"></p> <p data-bbox="886 844 1378 866"><b>g) Estimated range with remaining reagent.</b></p> <p data-bbox="916 882 1433 931">Refer to the information on “Reagent tank” in Section 1.</p>

## TRIP COMPUTER: journey parameters (8/8)

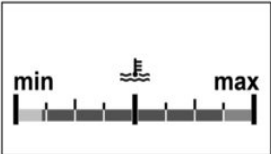
The display of information shown below **DEPENDS ON THE VEHICLE EQUIPMENT AND COUNTRY.**

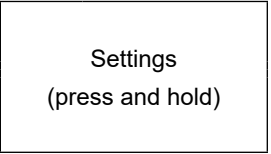
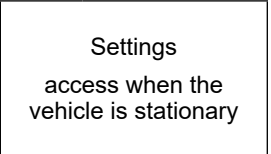
Examples of selections	Interpreting the display selected
	<p>➔ <b>h) Engine coolant temperature.</b></p>
	<p>➔ <b>i) Clock and outdoor temperature.</b></p>
	<p>➔ <b>j) General settings.</b> Press button <b>3</b> or <b>4</b> for approximately 5 seconds to select the display language.</p>
	<p>➔ Indicates that to access the "General settings" menu, you must stop the vehicle.</p>

## TRIP COMPUTER AND WARNING SYSTEM: information messages

These can help in the vehicle starting phase, or give information about a selection or a driving status. Examples of information messages are given in the following pages.

Examples of messages	Interpreting the display selected
<b>“Parking brake on”</b>	Indicates that the parking brake has been applied.
<b>“Vehicle Checks in Progress”</b>	Displayed with the ignition on when the vehicle is running self-diagnostics.
<b>“Turn steering wheel + START”</b>	Turn the steering wheel slightly whilst pressing the vehicle start button to unlock the steering column.
<b>“Steering wheel not locked”</b>	Indicates that the steering column has not been locked.

## TRIP COMPUTER: operating fault messages

These appear with the  warning light and mean that you should drive very carefully to an approved dealer as soon as possible. If you fail to follow this recommendation, you risk damaging your vehicle.

They disappear when the display selection key is pressed or after several seconds and are stored in the computer log. The  warning light stays on. Examples of operating fault messages are given in the following pages.

Examples of messages	Interpreting the display selected
“Clean Diesel Filter”	Indicates the presence of water in the diesel filter; contact an approved Dealer as soon as possible.
“Check Anti-Theft Steering Lock”	Indicates a fault in one of the pedal sensors, battery management system or oil level sensor.
“WARNING: Check Airbag”	Indicates a fault in the restraint system in addition to the seat belts. In the event of an accident, it is possible that they may not be triggered.
“Check Anti- Pollution System”	– Indicates a fault in the vehicle’s emission control system. – Indicates a fault in the emissions reduction system when it is accompanied by the  warning light. Refer to the information on “Reagent tank” in Section 1.
“WARNING: Check SOS Call”	Indicates a fault in the emergency call system.

## TRIP COMPUTER AND WARNING SYSTEM: warning message

These appear with the **STOP** warning light and require you to stop immediately, for your own safety, as soon as traffic conditions allow. Stop your engine and do not restart it. Contact an approved Dealer.

Some examples of warning messages are given below. **Note:** the messages appear on the display either individually or alternately (when there are several messages to be displayed), and may be accompanied by a warning light and/or a beep.

Examples of messages	Interpreting the display selected
“Engine failure hazard”	Indicates an injection fault, the vehicle’s engine has overheated or there is a serious engine fault.
“Power steering fault”	Indicates a fault in the steering system.
“WARNING: Braking System”	Indicates a fault in the braking system. Apply the electronic parking brake manually and ensure that the vehicle is immobilised using a chock.
“Electric failure DANGER”	Indicates a fault in the vehicle battery charging circuit (alternator etc.).
“WARNING: Gearbox Failure Risk”	Indicates an automatic gearbox fault.

## STEERING-WHEEL, POWER-ASSISTED STEERING (1/2)

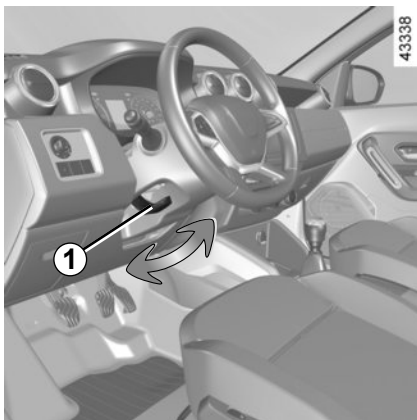

### Adjusting the steering wheel

Depending on the vehicle, the steering wheel height and depth are adjustable.

Pull lever **1** down and place the steering wheel in the required position; lift the lever again to lock the steering wheel in place.

Make sure that the steering wheel is correctly locked.



For safety reasons, only adjust the steering wheel when the vehicle is stationary.



### Steering wheel heating

(Depending on the vehicle)

This function heats the steering wheel in areas **3** and **4**.

#### Operating principle

When the temperature is reached, the function regulates the temperature of the heated areas for approximately 30 minutes and then switches off automatically.

#### Activating the function

With the ignition on, press the switch **2**, the warning light integrated in the switch lights up.

#### Deactivating the function

##### - Automatic:

The function switches off automatically after the regulation phase of approximately 30 minutes. The warning light integrated in the switch **2** remains on.

**Note:** If the function has switched off automatically, press the switch **2** twice to reactivate it.

If switch **2** is not pressed again, the function will be reactivated the next time the ignition is switched on.

##### - Manually:

To deactivate the function during the regulation phase, press the switch **2**. The indicator light in the switch **2** goes out.

# STEERING-WHEEL, POWER-ASSISTED STEERING (2/2)

## Power Assisted Steering

Never drive with an inadequately charged battery.

## Special case

Depending on the vehicle, in the event of a battery fault (disconnected, discharged battery, etc.), a reset of the power-assisted steering must be carried out. To do this:

- the vehicle stationary and on flat ground;
- driver alone in the vehicle, start the engine: the warning light  and/or, depending on the vehicle, the message “WARNING: Check Power Steering” is displayed on the instrument panel;
- turn the steering wheel fully to the left, then to the right. When the engine next starts, the indicator and/or, depending on vehicle, the message will switch off.

Never leave the steering wheel on full lock when the vehicle is stationary.

## Special feature of Stop and Start

With the engine on standby, power-assisted steering is no longer operational. It returns to its original state when the engine is restarted or when the speed moves above 1 mph or 1 km/h (hill, slope, etc.).



Never switch off the ignition when travelling downhill, and avoid doing so in normal driving (power steering and brake servo will not function).

With the engine switched off, or if there is a system fault, it is still possible to turn the steering wheel. The force required will be greater.



## REAR VIEW MIRRORS (1/2)

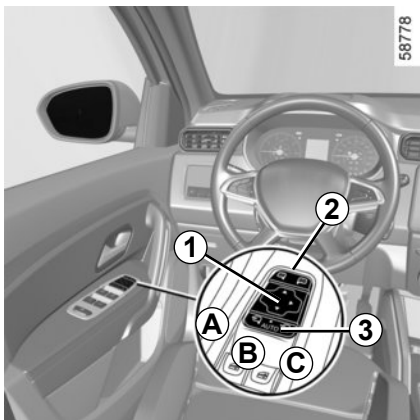

### Exterior rear view mirrors with electrical adjustment

#### Adjustment

Select the door mirror using switch **2**, then use button **1** to adjust it to the desired position.

#### Heated door mirrors

With the engine running, the rear screen is de-iced at the same time (refer to the "Heating, Ventilation, Air conditioning" paragraph in Section 3).

### Folding door mirrors

The door mirrors automatically fold out when the vehicle is unlocked (switch **3** in position **B**). The door mirrors fold in when the vehicle is locked.

In any case, you can make the rear view mirrors fold in (switch **3** in position **C**) or fold out (switch **3** in position **A**).

Automatic mode is then deactivated. To reactivate it, position switch **3** to **B**.



Objects observed in the door mirror glass are actually closer than they appear.

For your safety, take this into account in order to correctly assess the distance before any manoeuvre.



For safety reasons, carry out any adjustments when the vehicle is not being driven.

## REAR VIEW MIRRORS (2/2)

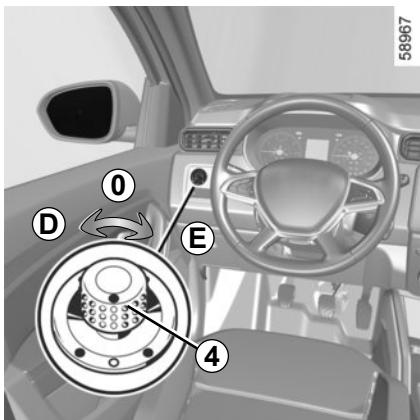

### Exterior rear view mirrors with electrical adjustment

(continued)

Depending on the vehicle, **with the ignition on**, activate the button **4**:

- position **D** to adjust the left-hand rear view mirror;
- position **E** to adjust the right-hand rear view mirror;

**0** is the neutral centre position.

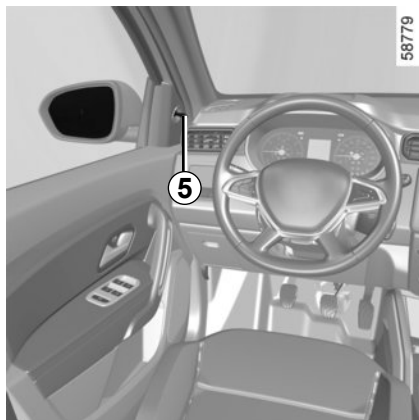

### Door mirrors with manual adjustment

To adjust the rear view mirror, move switch **5**.

### Folding rear view mirrors

Fold the door mirror manually against the door window.



### Interior rear view mirror

The interior rear view mirror is adjustable. When driving at night, tilt lever **6** to avoid being dazzled by the headlights of the vehicle behind.



For safety reasons, carry out any adjustments when the vehicle is not being driven.

## CLOCK AND EXTERIOR TEMPERATURE (1/2)

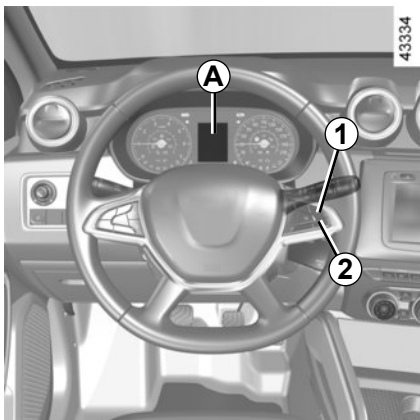

### Display A

To access the **3** display for setting the time, press and hold the **1** or **2** button for a few seconds.

The hour reading flashes. You are now in setting mode, press and hold the **1** or **2** button to set the hour.

Wait a few seconds, the minutes flash: repeatedly press the **1** or **2** button to set them.

When setting is complete, wait a few seconds before changing the display.

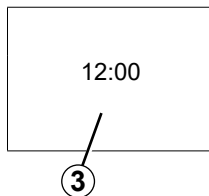

If the power supply is cut (battery disconnected, supply wire cut, etc.), the clock must be reset.

We recommend that you do not adjust these settings while driving.

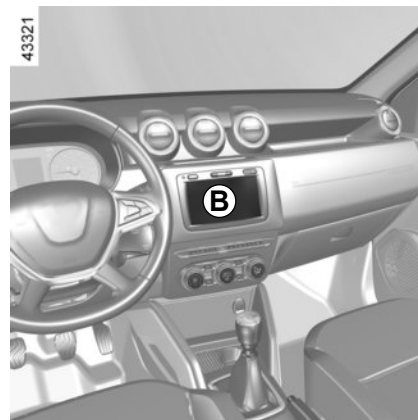

### Display B

**Vehicles fitted with a multimedia touch-screen, navigation aid systems, telephones, etc.**

Refer to the separate instructions for the function to understand the special features of this equipment.

## CLOCK AND EXTERIOR TEMPERATURE (2/2)

### External temperature indicator

#### Special note:

When the exterior temperature is  $-3^{\circ}\text{C}$  to  $+3^{\circ}\text{C}$ , the  $^{\circ}\text{C}$  characters flash (signalling a risk of ice on the road).



#### External temperature indicator

As ice formation is related to climatic exposure, local air humidity and temperature, the external temperature alone is not sufficient to detect ice.

If the power supply is cut (battery disconnected, supply wire cut, etc.), the clock must be reset.

We recommend that you do not adjust these settings while driving.

# AUDIBLE AND VISUAL SIGNALS

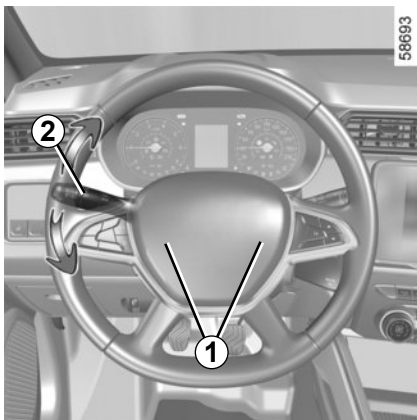

## Horn

Press at one of the locations **1**.

## Headlight flasher

Pull the stalk **2** towards you then release it to flash the headlights.

## Direction indicators

Move stalk **2** parallel to the steering wheel and in the direction you are going to turn it.

### One-touch mode

Briefly shift the stalk **2** upwards or downwards, not exceeding the point of resistance, then release it: the stalk will return to its original position and the direction indicator light concerned will flash three times.

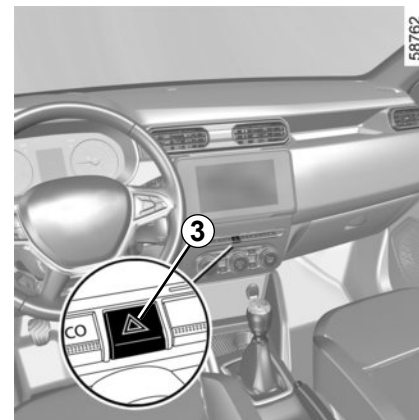

## Hazard warning lights

Press switch **3**.

This switch activates all four direction indicators and the side indicator lights simultaneously.

It must only be used in an emergency to warn drivers of other vehicles that you have had to stop in an area where stopping is prohibited or unexpected, or that you are obliged to drive under special conditions.

# EXTERIOR LIGHTING AND SIGNALS (1/4)

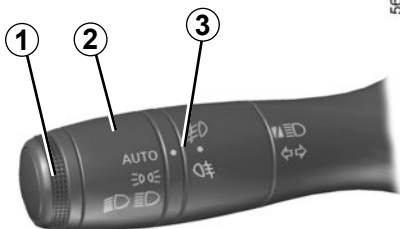

## Side lights

Turn the ring **2** until the symbol is opposite mark **3**.

An indicator light on the instrument panel will come on.

When driving on the left in a left-hand drive vehicle (or vice versa), drivers must readjust their lights throughout their stay (see “Adjusting headlight beams” in Section 1).

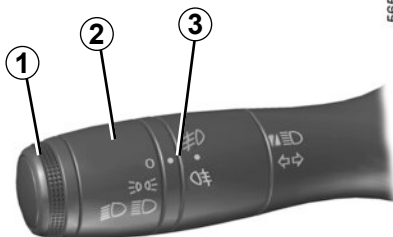

## Daytime running lights function

(front lights only)

If fitted on the vehicle, the daytime running lights come on automatically with no action on stalk **1** when the engine is started, and they go off once the engine is switched off.

**Note:** Daytime running light will go out automatically when the indicator is in operation.

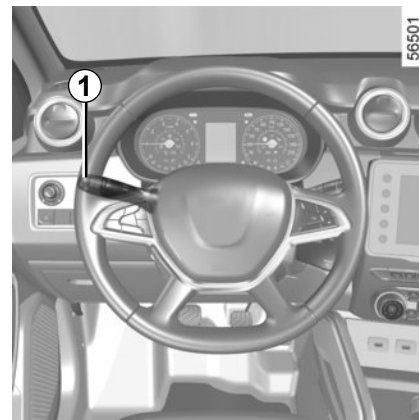

Before driving at night, check that the electrical equipment is operating correctly and adjust the headlight beams (if your vehicle is not carrying its normal load). As a general precaution, check that the lights are not obscured (by dirt, mud, snow or objects being transported).

## EXTERIOR LIGHTING AND SIGNALS (2/4)

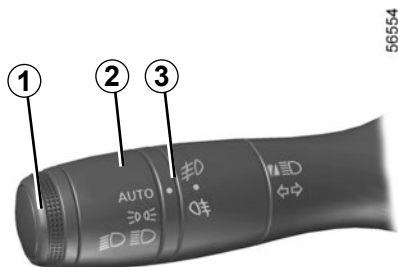

### Dipped beam headlights

#### Manual operation

Turn the ring **2** until the symbol is opposite mark **3**. This indicator light on the instrument panel comes on.

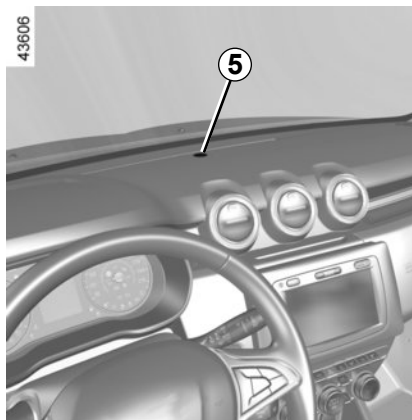

#### Automatic operation (depending on vehicle)

Turn ring **2** until the AUTO symbol is opposite mark **3**: with the engine running, the dipped beam headlights switch on or off automatically depending on the brightness of the light outside, without any action on stalk **1**.

Always make sure that:

- the windscreen is not obscured (dirt, mud, snow, condensation etc.);
- the light sensor **5** is not obscured (by dirt, objects etc.).

### Main beam headlights

With the engine running and the dipped beam headlights on, push stalk **1**. This indicator light on the instrument panel comes on.

To return to the dipped headlight position, pull stalk **1** towards you again.

### Switching off the dipped beam headlights

There are two possibilities:

- manually, move the **2** ring to position

 or, depending on the vehicle, to position **0**;

- the lights will go out automatically when the engine is switched off, the driver's door is opened or the vehicle is locked. In this case, when you start the engine the lights will be switched back on according to the position of the ring **2**, taking into account the exterior light level, without moving the stalk **1**.

## EXTERIOR LIGHTING AND SIGNALS (3/4)

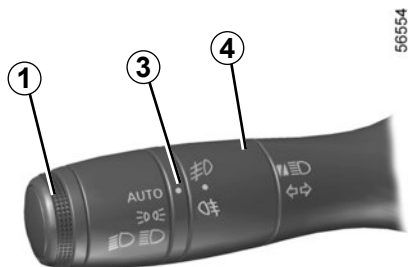

### Front fog lights

Turn centre ring **4** on stalk **1** until the symbol faces mark **3**, then release it.

Depending on the vehicle, the stalk returns to the initial position or stays in position.

Operation of the fog lights depends on the exterior lighting position selected, and an indicator light will light up on the instrument panel.

### Rear fog light

Turn centre ring **4** on the stalk until the symbol faces mark **3**, then release it.

Depending on the vehicle, the stalk returns to the initial position or stays in position.

Operation of the fog lights depends on the exterior lighting selected, and an indicator light will light up on the instrument panel.

To avoid inconveniencing other road users, remember to switch off the rear fog light when it is no longer needed.

### Turning off the fog lights

There are two possibilities:

- manually, depending on the vehicle, turn centre ring **4** again until mark **3** is opposite the symbol for the fog light that you wish to switch off. The corresponding indicator light will go out on the instrument panel;
- the lights will go out automatically when the engine is switched off or the vehicle is locked, and the fog lights when the driver's door is opened.

The front and rear fog lights switch off when the exterior lights are switched off.

When driving in fog or snow, or when transporting objects which are higher than the roof, the headlights do not come on automatically.

Switching on the fog lights remains the responsibility of the driver: the indicator lights on the instrument panel inform you whether the fog lights are lit (indicator light on) or not (indicator light not on).



## EXTERIOR LIGHTING AND SIGNALS (4/4)

### Welcome and goodbye function

(depending on the vehicle)

Once the function is activated, the daytime running lights and the rear side lights light up automatically on detecting the card or when the vehicle is unlocked and a beep sounds.

They switch off automatically:

- approximately one minute after lighting up;
- when starting the engine based on the position of the lighting stalk;

or

- upon locking the vehicle.

### Activating/deactivating the function

To activate or deactivate the external welcome function, please see the multimedia instructions.

Select “ON” or “OFF”.

### Lights-on reminder buzzer

A warning beep sounds when the driver's door is opened to warn you that the lights are still on.



Before driving at night, check that the electrical equipment is operating correctly and adjust the headlight beams (if your vehicle is not carrying its normal load). As a general precaution, check that the lights are not obscured (by dirt, mud, snow or objects being transported).

## ADJUSTING THE HEADLIGHT BEAM HEIGHT (1/2)



The control **A** is used to adjust the height of the headlight beams according to the load.

Turn control **A** anticlockwise to lower the beams and clockwise to raise them.

For manual settings	
Examples of positions for adjusting control <b>A</b> according to the load	
	Control <b>A</b>
<b>Driver alone or with front passenger</b>	<b>0</b>
<b>All seats occupied</b>	<b>1</b>
<b>Driver with a passenger and luggage (or load) reaching the maximum permissible all-up weight</b>	<b>2</b>
<b>Driver without passengers and luggage (or load) reaching the maximum permissible all-up weight</b>	<b>3</b>
The table below gives some examples. In all cases, adjust control <b>A</b> according to the vehicle load so that the road can be seen and other drivers are not dazzled.	

## ADJUSTING THE HEADLIGHT BEAM HEIGHT (2/2)

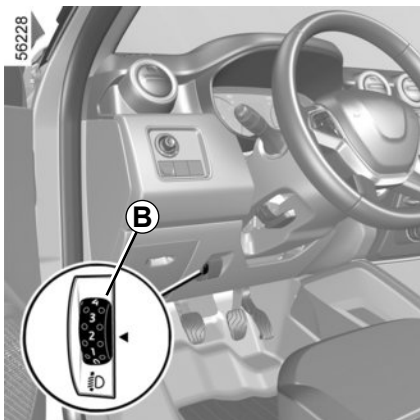

On vehicles fitted with this function, control **B** allows you to adjust the height of the beams according to the load.

Turn control **B** downwards to lower the headlights and upwards to raise them.

For manual settings	
Examples of positions for adjusting control <b>B</b> according to the load	
	Control <b>B</b>
	4x2, 4x4
Driver alone or with front passenger	0
All seats occupied	1
Driver with a passenger and luggage (or load) reaching the maximum permissible all-up weight	2
Driver without passengers and luggage (or load) reaching the maximum permissible all-up weight	3
The table below gives some examples. In all cases, adjust control <b>B</b> according to the vehicle load so that the road can be seen and other drivers are not dazzled.	

# SCREEN WASHER, WIPER (1/4)

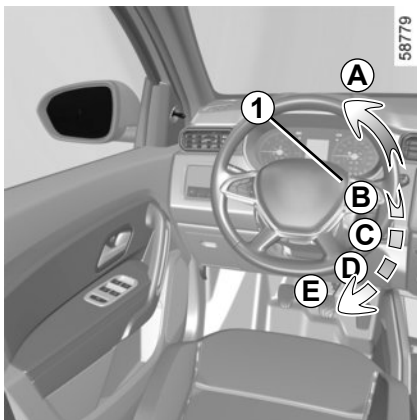

## Wipers

With the ignition on, move stalk **1** around the steering wheel:

- A** Single wipe  
A short push will trigger one sweep of the wipers.
- B** Off.
- C** Intermittent wiping.  
The wipers will pause for several seconds between sweeps.
- D** Continuous normal wipe.
- E** Continuous fast wipe.



## Wipers

With the ignition on, pull stalk **1** towards you.

A brief pull will trigger a single sweep of the wipers, in addition to the windscreen washer.

A longer pull will trigger three sweeps of the wipers, in addition to the windscreen washer.



Before any action on the windscreen (washing the vehicle, de-icing, cleaning the windscreen, etc.), return stalk **1** to position **B** (park).

**Risk of injury and/or damage.**



When working in the engine compartment, ensure that the windscreen wiper stalk is in position **B** (park).

**Risk of injury.**

## Efficiency of a wiper blade

Check the condition of the wiper blades. How long they last depends on you:

- it must remain clean: clean the blade and the screen regularly with soapy water;
- do not use it when the screen is dry;
- free it from the screen when it has not been used for a long time.

In any event, replace them as soon as they begin to lose efficiency: approximately every year (refer to the information on “Wiper blades: replacement” in section 5).

## Precautions for using the wipers

- In freezing or snowy weather, clear the screen before starting the wipers (risk of motor overheating);
- ensure that no objects are obstructing the travel of the blade.

## SCREEN WASHER, WIPER (2/4)

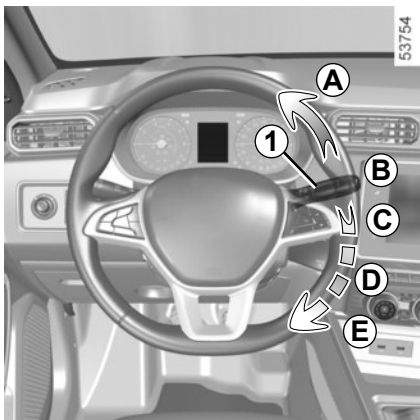

### Vehicle fitted with front windscreen wiper rain sensor

The rain sensor is located on the windscreen, in front of the interior rear-view mirror.

#### **A** single sweep

A short push will trigger one sweep of the wipers.

#### **B** stop

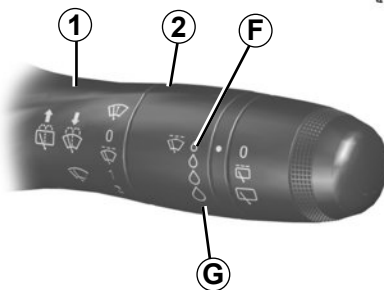

#### **C** automatic wiper function (de-

pending on the vehicle)

When this position is selected, the system detects water on the windscreen and triggers the wipers at a suitable wiping speed. It is possible to change the triggering threshold and the time sweeps by turning ring 2:

- **F**: minimum sensitivity;
- **G**: maximum sensitivity.

The higher the sensitivity, the quicker the wipers will react and the faster the wipe.

When activating automatic wiping or when increasing sensitivity, one sweep of the blades is performed.

#### **Note:**

- the rain sensor is only intended as a driving aid. In the event of reduced visibility, the driver should manually activate the wipers. In foggy weather or during snowfalls, wiping is not automatically triggered and remains under the driver's control;
- in the event of temperatures below zero, automatic wiping is not activated when the vehicle is started. It is automatically activated as soon as the vehicle exceeds a certain speed (approximately 5 mph (8 km/h));
- do not activate automatic wiping in dry weather;
- fully de-ice the windscreen before activating automatic wiping;
- when washing the vehicle under a roller type car wash, return the ring **1** to position **B** in order to deactivate automatic wiping.

# SCREEN WASHER, WIPER (3/4)

## Operating faults

In the event of a malfunction of the automatic wiping, the wiper is set to intermittent wiping. Contact an authorised dealer.

The operation of the rain sensor can be disturbed in the event of:

- damaged windscreen wipers; a film of water or traces left by a blade in the sensor's detection zone may increase the response time of the automatic wiper, or increase the wiping frequency;
- a windscreen with any chip or crack level with the sensor, or a windscreen covered in dust, dirt, insects, ice, the use of washing wax and water-repellent chemicals; the windscreen wiper will be less sensitive or may even not react at all.

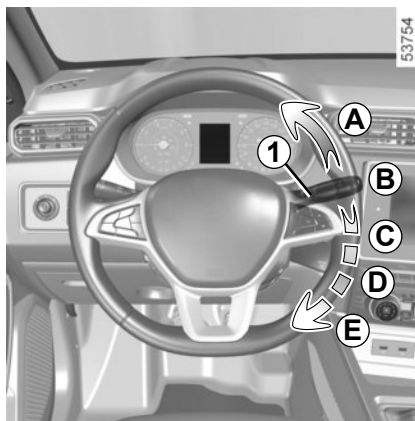

**D** slow continuous wiping

**E** fast continuous wiping

## Special note

**When driving the vehicle**, the wiping speed slows down whenever the vehicle stops. For example, fast wiping speed will slow to normal wiping speed. As soon as the vehicle moves off, wiping will return to the speed originally selected.

If stalk **1** is operated, it overrides and cancels the automatic function.

## Precautions

- In the event of ice, check whether the blades are stuck to the windscreen before operating the wiping mechanism. If you activate the wipers while the blades are stuck down with ice, you may risk damaging both the blade and the wiper motor.
- Do not activate the wipers on a dry screen. This will lead to premature wear or damage to the blades.

## Heater jets

(depending on the vehicle)

The jets are heated if you activate the windscreen demister.

## SCREEN WASHER, WIPER (4/4)

56552

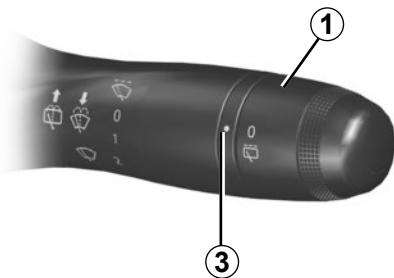

### Rear screen wiper

With the ignition on, turn the end of stalk **1** to align the symbol with mark **3**.



### Rear screen washer/ wiper

With the ignition on, push and hold stalk **1**, then release.

A longer action will trigger three sweeps of the wipers followed, a few seconds later, by a fourth, in addition to the wind-screen washer.

Do not use the wiper arm to open or close the tailgate.



Before any action involving the rear screen (washing the vehicle, de-icing, cleaning, etc.) return stalk **1** to the stop position.

**Risk of injury and/or damage.**

### Efficiency of a wiper blade

Check the condition of the wiper blades. How long they last depends on you:

- it must remain clean: clean the blade and the screen regularly with soapy water;
- do not use it when the screen is dry;
- free it from the screen when it has not been used for a long time.

In any event, replace them as soon as they begin to lose efficiency: approximately every year (refer to the information on “Wiper blades: replacement” in section 5).

### Precautions for using the wipers

- In freezing or snowy weather, clear the screen before starting the wipers (risk of motor overheating);
- ensure that no objects are obstructing the travel of the blade.

## FUEL TANK (1/6)

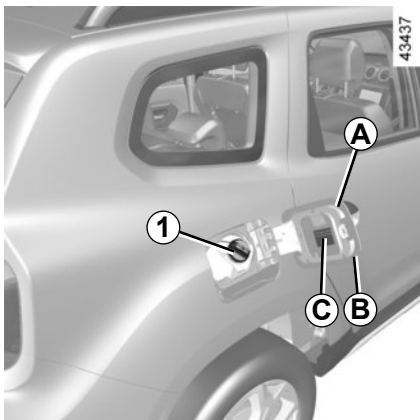

### Petrol and diesel versions

**Usable capacity of the fuel tank:  
50 litres** approximately.

To open the cover **A**, place your finger in the cutout **B** or, depending on the vehicle, pull the lever **2**, to unlock the cover **A**: the cover will open slightly.

Depending on the vehicle, the filling cap **1** unlocks with the ignition key. Otherwise, it is connected to the vehicle by a strip of plastic.

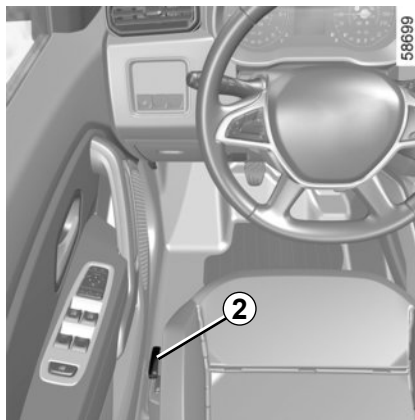

Unscrew the cap **1**. Use the cap holder **3** on the flap **A** during filling to hold the cap **1** in place.

For details on filling the fuel tank, refer to the information on "Filling with fuel".

After filling, refit the plug **1** and close the cover **A** fully by hand.

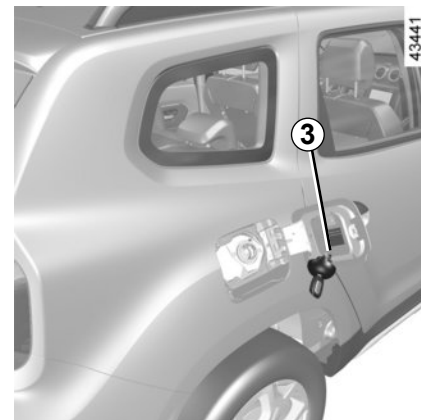

**Fuel filler cap: this is specific to the vehicle type.** If

you have to replace it, make sure the new cap is of the same type. Contact an approved dealer.

Never place the cap near a source of heat or flame.

Do not wash the filler area with a high-pressure washer.



## FUEL TANK (2/6)

### Fuel grade

**Always use a high-grade fuel** that complies with the legislation in force in each country. It must conform to the specifications given on label **C** inside the fuel filler flap.

**Refer to the “Engine specifications” table in Section 6.**



To fill up with fuel, the engine must be stopped (and not only on standby in the case of vehicles equipped with the STOP and START) function: you must switch off the ignition. Please refer to the information on “Starting, stopping the engine” in Section 2.

**Fire hazard.**

### Petrol version

It is essential to use unleaded petrol. The octane rating (RON) must conform to the specifications given on the label inside fuel filler flap **C**.

### Diesel version

It is essential to use diesel fuel that conforms to the specifications given on the label **C** inside the fuel flap.

Fuel types that conform to European standards with which the engines of vehicles sold in Europe are compatible: refer to the “Engine specifications” in section 6.



Do not mix even small amounts of petrol (unleaded or E85) with diesel.

Do not use ethanol-based fuel if your vehicle is not compatible with this fuel.

Do **not** add reagent to the fuel – otherwise you risk damaging the engine.

If you wish to add an additive to the fuel, use a product approved by our Technical Department.

Consult an approved dealer.

## FUEL TANK (3/6)

### Filling with fuel

With the ignition off, insert the nozzle to open the valve and insert it **fully** before turning it on to fill the tank (risk of splashing).

Keep the nozzle in this position throughout the entire filling operation. When the pump cuts out automatically at the end of the filling procedure, a maximum of two further filling attempts may be made, as there must be sufficient space in the fuel tank to allow for expansion.

Make sure that no water enters the fuel tank during filling. The valve and its surround must remain clean.

After filling, refit the cap **1** to prevent any water or foreign bodies from entering the system.

### Petrol version

Using leaded petrol will damage the antipollution system and may lead to a loss of warranty.

To ensure that the fuel tank is not filled with leaded petrol, the fuel tank filler neck contains a restrictor fitted with a foolproof system which **only allows the nozzle for unleaded petrol to be used** (at the pump).



### Persistent fuel odour

If you notice a persistent smell of fuel you should:

- stop the vehicle when traffic conditions allow it and switch off the ignition;
- switch on the hazard warning lights and ask your passengers to leave the vehicle and stay clear of the traffic;
- contact an authorised dealer.

## FUEL TANK (4/6)

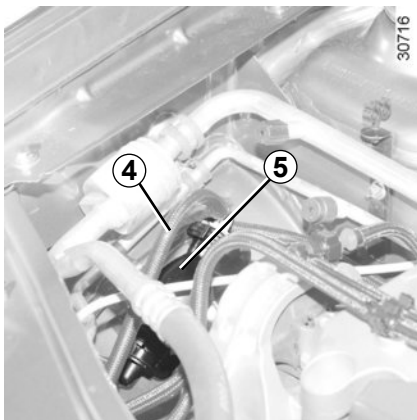

### Priming bulb

(diesel version)

After a breakdown caused by completely running out of fuel, the system must be reprimed before the engine is restarted:

**Note:** the bulb is always located on the right-hand side of the engine compartment.

Operate priming bulb **5** until the fuel flows through the hose **4**.

If the engine does not start after several attempts, contact an approved dealer.



No modifications whatsoever are permitted on any part of the fuel supply system (computers, wiring, fuel circuit, injector, protection covers, etc.) as this may be dangerous (such work must be undertaken by qualified Network personnel).



Please note when working close to the engine that it may be hot. The engine cooling fan may also start

at any moment. The  warning light in the engine compartment reminds you of this.

**Risk of injury.**

## FUEL TANK (5/6)

Useful capacity of LPG tank: approximately 7.48 gal (34 litres) or 10.78 gal (49 litres) (depending on the vehicle).

### Filling up with LPG

Engage the handbrake, stop the engine, switch off the ignition and switch off the lights. Always respect the safety instructions given at filling stations.

Depending on the country, before refilling you must screw the filling adapter **6** onto the LPG filler end piece.

It is always advisable to completely fill the tank.

When the pump stops delivering LPG, or when the pump flow reduces significantly, the maximum LPG level has been reached.

At this point, do not attempt to carry on filling.

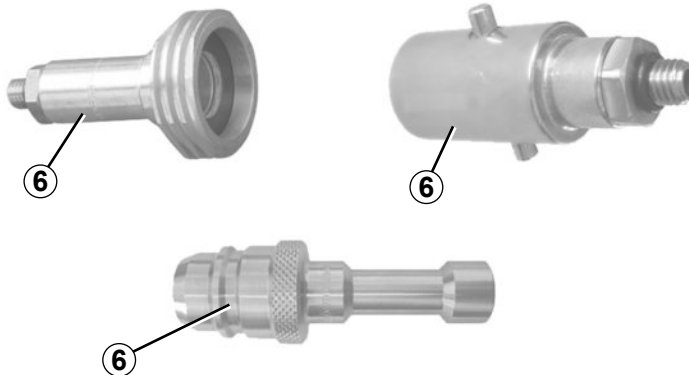

36115

### Filling stations without self-service

If the service station personnel carry out the LPG filling procedure, you must give them the adapter **6**.

#### **IMPORTANT: LPG filling adapter 6**

Depending on the country, the use of a specific adapter is required for LPG filling.

The filling adapter **6** is provided in a pouch in the glove box. It may or may not be present in the vehicle, depending in which country the vehicle was sold.

Before driving the vehicle to another country, it is essential to consult an approved dealer to find out the type of adapter to use if necessary.

## FUEL TANK (6/6)

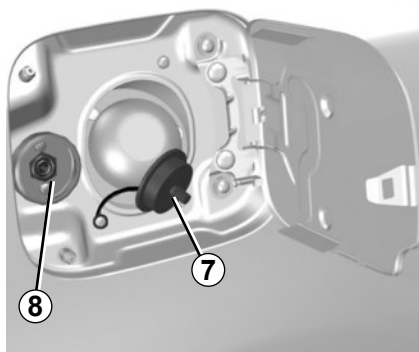

### Filling stations with self-service

We recommend that you wear gloves when handling the LPG pistol.

Open your vehicle's tank cover and unscrew the cap **7** from the end piece of the LPG filler **8**.

Carefully follow the information explaining how to refill using the LPG distributor.

Depending on the type of station, it may be necessary to perform press and hold the station button before filling will start.

When the pump finishes or if it has difficulties operating, this means that the maximum tank fill level (80%) has been reached.

The filling will stop as soon as you release the button. Release the stop lever (a small amount of gas may be released), lift the pistol and place it on the distributor.

After filling, refit the cap **7** to prevent any water or foreign bodies from entering the system.

## REAGENT TANK (1/5)

Please ensure that you comply with the legislation of your country.

It is important to remember that failure to respect regulations in force could lead to legal action being taken against the vehicle owner.

### Operating principle

The reagent is intended for diesel engines fitted with the SCR (selective catalytic reduction) system.

Using a reagent reduces the quantity of nitrogen oxides in exhaust gases.

Reagent consumption in real time depends on vehicle usage conditions, the equipment fitted, and driving style.

### Reagent quality

Use **only reagents which conform to standard ISO 22241** and in accordance with the mark on the tank filler cap.

To fill up with reagent, the engine must be stopped (not just on standby in the case of vehicles with the **STOP and START** function). You must switch off the ignition. Please refer to the information on “Starting, stopping the engine” in Section 2.



**If the “xxxKM failure Top up AdBlue” message appears, fill the reagent tank and refer to the filling instructions.**  
**Risk of immobilisation of the vehicle.**

## REAGENT TANK (2/5)

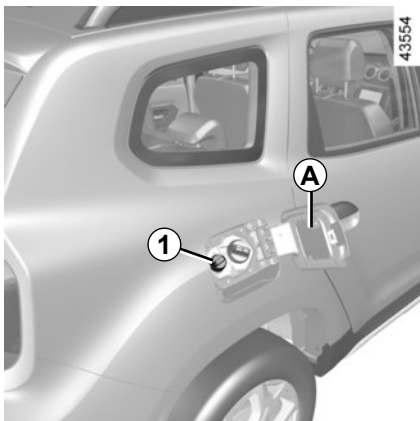

### Filling

#### Useable tank capacity:

approximately **3.30 gal (15 litres)** or **3.16 gal (14.4 litres)**, depending on the vehicle.

With the ignition switched off, open the cover **A**, then unscrew the cap **1**.

**Note:** ammonium hydroxide vapour may escape from the cap opening when the tank temperature is high.

The tank can be filled at the pump. With the ignition off, insert the nozzle and insert it **fully** before turning it on to fill the fuel tank (risk of splashing).

Keep the nozzle in this position throughout the entire filling operation.

When the pump cuts out automatically at the end of the filling procedure, a maximum of two further filling attempts may be made, as there must be sufficient space in the fuel tank to allow for expansion.

In other filling cases, it is essential to read the information shown on the reagent container (e.g. the can or bottle).



#### Filler cap: this is specific.

If you have to replace it, make sure it is identical to the original cap. Contact an approved Dealer. Do not wash the filler area with a high pressure washer.

### Precautions for use

When filling:

- **handle the reagent with care. They can damage clothes, shoes, bodywork components etc.**
- make sure that no water enters the fuel tank.

If the reagent overflows, or contaminates any paintwork, clean the affected area quickly with plenty of cold water and a soft cloth.

**Note:** if the reagent crystallises, use a soft sponge.



The reagent must not come into contact with eyes or skin. If it does, wash the affected area with plenty of cold water. If necessary, consult a doctor.

## REAGENT TANK (3/5)

### In extreme cold weather conditions

In frosty weather conditions, the reagent tank should be refilled when the



indicator and the message "Top Up AdBlue before 1200 km" appear on the instrument panel.

### Special cases

The reagent fluid freezes below about -10°C.

In these conditions, do not attempt filling when the fluid is frozen. In the event of needing to top up or fill the tank with

reagent (  on), park the vehicle in a hotter location if possible so that the reagent becomes liquid again. Otherwise, have a qualified professional top up or fill up with reagent fluid.

After filling the reagent tank, check that the cap and cover are closed, start the engine and **WAIT 10 seconds with the vehicle stationary, engine running** before setting off again.

If this operation is not carried out, the filling of the tank will not be taken into account automatically until after several dozens of minutes of driving.

The message "--- TOP UP AdBlue" and/or the warning lights will continue to appear until the filling has been taken into account by the system.





No work whatsoever is permitted on any part of the system. To prevent damage, only qualified personnel from our network may work on the system.



# REAGENT TANK (4/5)

## Maintenance/Range







The information displayed on the instrument panel may be accompanied by a beep.

Indicator lights	Message	What to do?
–	“Top Up AdBlue before 2400 km”	When the message is displayed when the ignition is switched on, you have <b>less than 1,488 miles (2,400 km) range</b> . Fill or have an Approved Dealer <b>fill or top up the reagent</b> in the tank.
 comes on.	“TOP UP AdBlue before 1200 km”	When the message is displayed when the ignition is switched on, you have <b>between 744 miles (1,200 km) and 496 miles (800 km) range</b> . Fill or have an Approved Dealer <b>fill or top up the reagent</b> in the tank.
 comes on.	“xxxKM failure Top up AdBlue”	The message is displayed when the ignition is switched on and is repeated: – approximately every 62 miles (100 km), you have <b>between about 496 miles (800 km) and 124 miles (200 km) range</b> ; – approximately every 31 miles (50 km), you have <b>less than 124 miles (200 km) range</b> . In any event, fill or have an Approved Dealer <b>fill the reagent tank as soon as possible</b> .
 comes on.	« 0KM FAILURE TOP UP ADBLUE »	<b>The engine will not start.</b> To restart, you must fill the reagent tank yourself.

# REAGENT TANK (5/5)

## System faults

The information displayed on the instrument panel may be accompanied by a beep.

Indicator lights	Message	Readings
 and  come on.	« CHECK ANTI- POLLUTION SYSTEM » “AdBlue quality to check” “AdBlue injection to check”	Indicates a fault in the system. Contact your approved dealer as soon as possible.
 and  come on.	“xxxKM failure antipollution”	Indicates a system fault and that in <b>less than 496 miles (800 km) it will become impossible to restart the vehicle.</b>  These warnings are repeated: – every 62 miles (100 km) until there are <b>between 500 miles (800 km) and 124 miles (200 km) remaining</b> before the vehicle cannot be restarted; – every 31 miles (50 km) when there is <b>less than 124 miles (200 km) left</b> before the vehicle cannot be restarted.  Contact your approved dealer as soon as possible.
 and  come on.	« 0KM FAILURE TOP UP ADBLUE »	Indicates that after the ignition is switched off <b>the vehicle will not restart.</b> Call an approved Dealer.

# **Section 2: Driving**

## **(Advice on use relating to fuel economy and the environment)**

Running in, Ignition switch . . . . .	2.2
Starting, Stopping the engine: vehicle with key . . . . .	2.3
Starting, stopping the engine: vehicle with card . . . . .	2.7
Stop and Start function . . . . .	2.13
Special features of petrol versions . . . . .	2.17
Special features of diesel versions . . . . .	2.19
Special features of LPG versions . . . . .	2.21
Driving advice, ECO-driving . . . . .	2.25
Maintenance and antipollution advice . . . . .	2.30
Environment . . . . .	2.31
Tyre pressure loss warning . . . . .	2.32
Gear lever/Handbrake . . . . .	2.36
Transmission: 4-wheel drive (4WD) . . . . .	2.37
Driver correction devices and aids . . . . .	2.42
Speed limiter . . . . .	2.47
Cruise control . . . . .	2.52
Automatic gearbox. . . . .	2.58
Parking distance control . . . . .	2.62
Reversing camera . . . . .	2.66
Blind spot warning . . . . .	2.69
Multi-view camera . . . . .	2.73
Emergency call . . . . .	2.79

# RUNNING IN, IGNITION SWITCH

## Petrol version

For the first **600 miles (1,000 km)**, do not exceed 80 mph (130 km/h) in the highest gear, or 3,000 to 3,500 rpm.

You may only expect top performance from your vehicle after approximately **1,800 miles (3,000 km)**.

**Service intervals:** refer to the Maintenance Service Booklet for the vehicle.

## Diesel version

For the first **1,000 miles (1,500 km)**, do not exceed 80 mph (130 km/h) in the highest gear, or 2,500 rpm. After completing this mileage you may drive faster, although you may only expect top performance after approximately 3,600 miles (6,000 km).

During the running in period, do not accelerate hard while the engine is still cold and do not let the engine over-rev.

**Service intervals:** refer to the Maintenance Document for your vehicle.

**Note:** for a new vehicle in the running-in phase: the coolant level may be higher than the “**MAXI**” mark on the tank, then drop to between the “**MINI**” and “**MAXI**” marks.

This does not present a risk.

## Off position **A** (steering lock applied)

To lock: remove the key **1** and turn the steering wheel until the steering column locks.

To unlock: turn the key and the steering wheel slightly.

## “Accessories” position **B**

When the ignition is switched off, any accessories (radio, etc.) will continue to function.

## “Ignition” position **C**

The ignition is switched on:

- **petrol version:** the engine may be started.
- **diesel version:** the engine is pre-heating.

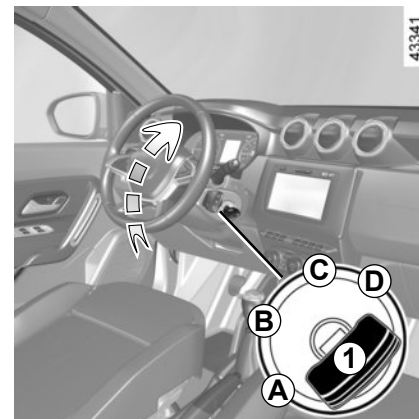

## “Start” position **D**

If the engine fails to start at the first attempt, turn the key back before activating the starter again.

Release the key as soon as the engine starts.

## Special note on vehicles with an automatic gearbox

Refer to the information on the “Automatic gearbox” in Section 2.

# STARTING, STOPPING THE ENGINE: vehicle with key (1/4)

## Starting the engine

Depending on the vehicle, if a gear is engaged, for the engine to be started, you must depress the clutch pedal or put the gear lever in neutral. The message “Neutral + START” appears on the trip computer to notify you.

In very cold conditions (temperatures below  $-20^{\circ}\text{C}$ ): so that it is easier to start the engine, switch on the ignition for several seconds **before** starting the engine.

When starting the engine, if the outdoor temperature is very low (below  $-10^{\circ}\text{C}$ ): hold down the clutch pedal until the engine starts.



Never start your vehicle while freewheeling on a gradient. Risk of non-activation of power-assisted steering.

**There is a risk of accidents.**

## Petrol version

- Turn the key to the start position **without depressing the accelerator**.
- Release the key as soon as the engine starts.



## Diesel version

Turn the ignition key to ignition “On” position **C** and hold this position until the preheating warning light goes out.

Turn the key to the “Start” position **D** **without depressing the accelerator pedal**.

Release the key as soon as the engine starts.

## vehicles with an automatic gearbox

Before starting, move the lever to position P.

Refer to the information on the “Automatic gearbox” in Section 2.

## Stopping the engine

With the engine idling, turn the key back to “Stop” position **A**.

## Special note

Depending on the vehicle, accessories (e.g. radio) stop working either when the engine is switched off or when the driver’s door is opened or when the doors are locked.

## STARTING, STOPPING THE ENGINE: vehicle with key (2/4)

### LPG version

The engine is always started using petrol.

**While the fuel tank is empty, the vehicle cannot start or drive in LPG mode only.**

Bi-fuel operation using LPG/petrol requires the presence of petrol (for starting, high acceleration, cold temperatures, etc.).

If the orange warning light  appears on the instrument panel and a beep sounds, fill the tank with fuel as soon as possible.

For more information on LPG versions, please refer to the “Special features of LPG versions” paragraph in Section 2.



Never switch off the ignition before the vehicle has stopped completely. Once the engine has stopped, the brake servo, power-assisted steering, etc., and the passive safety devices such as the airbags and pretensioners will no longer operate.



Do not park the vehicle or run the engine in locations where combustible substances or materials such as grass or leaves can come into contact with a hot exhaust system.



### **Driver's responsibility**

Never leave an animal, child or adult who is not self-sufficient alone on your vehicle, even for a short time.

They may pose a risk to themselves or to others by starting the engine, activating equipment such as the electric windows or locking the doors, for example.

Also, in hot and/or sunny weather, please remember that the temperature inside the passenger compartment increases very quickly.

**Never switch off the ignition before the vehicle has stopped completely.** Switching off the engine disables the assistance equipment: brakes, steering, etc., and additional seatbelt devices.

The steering is locked when the key is removed.

**RISK OF DEATH OR SERIOUS INJURY.**

## STARTING, STOPPING THE ENGINE: vehicle with key (3/4)

39814

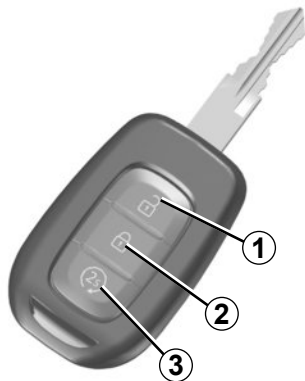

### Remote engine start-up

#### Initialisation

If the vehicle is so equipped, press the unlocking button **1** then press the remote start button **3** twice in succession for about 3 seconds each time. The time between the two presses must be less than 5 seconds. The hazard warning lights will come on continuously for 3 seconds to confirm the system reset.

**Note:** once the function has been activated, it cannot be disabled.

We advise you to contact an Approved Dealer.

#### Operation

This function allows remote starting of the engine.

Adjust the thermal comfort level as required (temperature, de-icing).

To start the engine remotely, press the locking button **2**, then within another 2 seconds, press the remote start button **3** for approximately 3 seconds. The hazard lights come on continuously for approximately 3 seconds and the engine starts.

The engine will run for 10 minutes. Once the engine is running, it is possible to extend the running-time for 10 minutes by pressing again on the remote start button **3**. The hazard lights come on continuously for 3 seconds to confirm that the function has been prolonged.

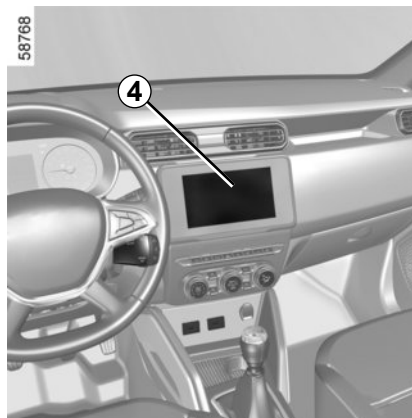

This function also lets you programme the engine to start, in order to heat or ventilate the passenger compartment up to 24 hours before using the vehicle. Depending on the vehicle, configuration and programming are performed using the multimedia display **4**, or using your smartphone. Please refer to the multimedia instructions for your vehicle.



Before using the “Remote engine start-up” function, check that the vehicle is immobilised (please refer to the “Parking brake” paragraph in Section 2).

**Risk of accident and serious injury.**

## STARTING, STOPPING THE ENGINE: vehicle with key (4/4)

Remote engine start performance varies according to surroundings such as:

- Obstacles, buildings, walls, other vehicles, etc.;
- the vehicle is located in a high electromagnetic radiation zone;
- Condition of the key/card battery.

The remote engine start-up operates if:

- the lever is in neutral position on vehicles with a manual gearbox;
- the lever is in position **P** for vehicles with an automatic gearbox;
- the ignition is off and no key is inserted into the ignition switch;
- the bonnet is closed;
- all of the opening elements (doors and luggage compartment) are closed and locked when you leave the vehicle;
- in extreme weather conditions, the remote engine start-up by programming may not work.

If one of these conditions is not met, the lights will flash for approximately 3 seconds.



In the event that the function is used, please ensure that power-consuming devices (such as the wipers, exterior lights, radio, heated seats, heated steering wheel, etc.) are deactivated and all accessories are disconnected before leaving the vehicle.

**Fire hazard.**



Do not use the engine remote start-up function or its programming when:

- the vehicle is in a garage or in a confined space.

**Risk of poisoning or suffocation by exhaust gas emissions.**

- the vehicle is covered with a protective cover.

**Fire hazard.**

- the bonnet is open or before it opens.

**Risk of burns or serious injury.**

**Depending on the country, the remote start function or its programming may be prohibited by law and/or by the regulations in force.**

**Before using this function, check the legislation and/or the regulations in force for the country.**



## STARTING, STOPPING THE ENGINE: vehicle with card (1/6)



The card must be inserted in detection zone **1**.

To start:

- vehicles with an automatic gearbox, place the lever in position **P**, depress the brake pedal and press button **2**;
- vehicles with a manual gearbox, depress the brake or clutch pedal and press the button **2**. If a gear is engaged, the vehicle may only be started by depressing the clutch pedal.



### Special features

- If one of starting conditions is not applied, the message “Press Brake + START” or “Press Clutch + START” or “Select “P” Then Press Start” is displayed on the instrument panel;
- in some cases, it will be necessary to move the steering wheel whilst pressing the start button **2** to help unlock the steering column; the message “Turn steering wheel + START” will warn you of this;

### LPG version

The engine is always started using petrol.

**While the fuel tank is empty, the vehicle cannot start or drive in LPG mode only.**

Bi-fuel operation using LPG/petrol requires the presence of petrol (for starting, high acceleration, cold temperatures, etc.).

If the orange warning light  appears on the instrument panel and a beep sounds, fill the tank with fuel as soon as possible.

For more information on LPG versions, please refer to the “Special features of LPG versions” paragraph in Section 2.

## STARTING, STOPPING THE ENGINE: vehicle with card (2/6)

### “Hands-free” starting with the tailgate open

In this case, the card must not be located in the luggage compartment.



#### **Driver's responsibility when parking or stopping the vehicle**

Never leave an animal, child or adult who is not self-sufficient alone in your vehicle, even for a short time.

They may pose a risk to themselves or to others by starting the engine, activating equipment such as the electric windows or locking the doors, for example.

Also, in hot and/or sunny weather, please remember that the temperature inside the passenger compartment increases very quickly.

**RISK OF DEATH OR SERIOUS INJURY.**

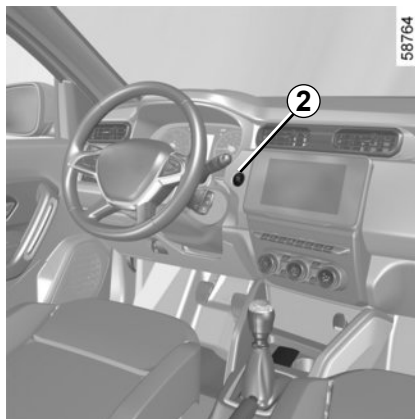

#### **Accessories function**

(switching on the ignition)

Once you have gained access to your vehicle, you may use some of its functions (radio, navigation, wipers, etc.).

To use the other functions, with the card in the passenger compartment, press the **2** button without pressing the pedals.

## STARTING, STOPPING THE ENGINE: vehicle with card (3/6)

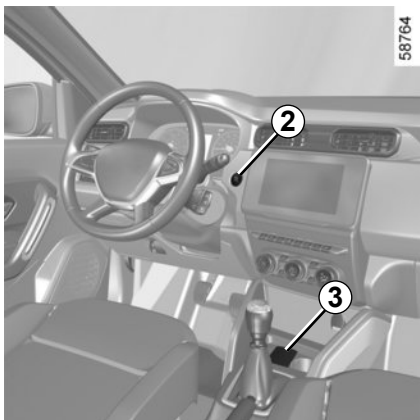

### Operating faults

In certain cases, the hands-free card may not work:

- when the card battery is drained, flat battery, etc.,
- near to appliances operating on the same frequency as the card (monitor, mobile phone, video game, etc.);
- vehicle located in a high electromagnetic radiation zone.

The message “Place Card Near Symbol + START” appears on the instrument panel.

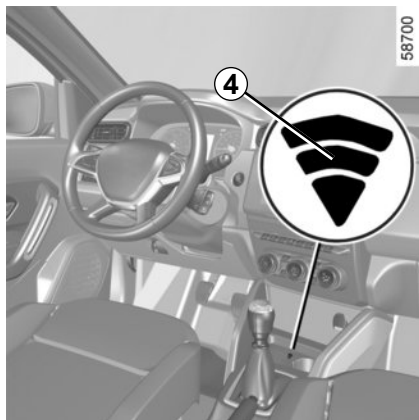

Depress the brake or clutch pedal, then place the 3 card on the 4 symbol. Press the 2 button to start the vehicle. The message goes out.



Do not park the vehicle or run the engine in locations where combustible substances or materials such as grass or leaves can come into contact with a hot exhaust system.



Never switch off the ignition before the vehicle has stopped completely. Once the engine has stopped, the brake servo, power-assisted steering, etc., and the passive safety devices such as the airbags and pretensioners will no longer operate.

## STARTING, STOPPING THE ENGINE: vehicle with card (4/6)



### Conditions for stopping the engine

The vehicle must be stationary, with the lever positioned in **P** for vehicles with an automatic gearbox.

With the card in the vehicle, press button **2**: the engine stops. The steering column is locked when the driver's door is opened or the vehicle is locked.

If the card is no longer in the passenger compartment or if the card's battery is dead, when the vehicle is stationary and you try to switch the engine off, the message "Keycard absent: press/hold START" appears on the instrument panel: press button **2** for longer than three seconds. If the card is no longer in the passenger compartment, make sure you can retrieve it before pressing and holding the button. Without the card, you will not be able to restart the vehicle.

With the engine switched off, any accessories being used (radio, etc.) will continue to function for approximately 10 minutes.

When the driver's door is opened, the accessories stop working.



Never switch off the ignition before the vehicle has stopped completely. Once the engine has stopped, the brake servo, power-assisted steering, etc., and the passive safety devices such as the airbags and pretensioners will no longer operate.



Do not park the vehicle or run the engine in locations where combustible substances or materials such as grass or leaves can come into contact with a hot exhaust system.



When you leave your vehicle, especially if you have your card with you, check that the engine is completely switched off.

## STARTING, STOPPING THE ENGINE: vehicle with card (5/6)

43553



### Remote engine start-up

#### Initialisation

If the vehicle is so equipped, press the unlocking button **6**, then press the remote start button **5** twice in succession for about 3 seconds each time. The time between the two presses must be less than 5 seconds. The hazard warning lights will come on continuously for 3 seconds to confirm the system reset.

**Note:** once the function has been activated, it cannot be disabled.

We advise you to contact an Approved Dealer.

#### Operation

This function allows remote starting of the engine.

Adjust the thermal comfort level as required (temperature, de-icing).

To start the engine remotely, press the locking button **7**, then within another 2 seconds, press the remote start button **5** for approximately 3 seconds. The hazard lights come on continuously for approximately 3 seconds and the engine starts.

The engine will run for 10 minutes. Once the engine is running, it is possible to extend the running-time for 10 minutes by pressing again on the remote start button **5**. The hazard lights come on continuously for 3 seconds to confirm that the function has been prolonged.

58768

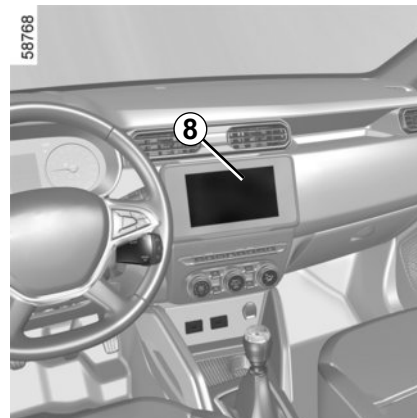

This function also lets you programme the engine to start, in order to heat or ventilate the passenger compartment up to 24 hours before using the vehicle. Depending on the vehicle, configuration and programming are done using the multimedia display **8**, refer to the multimedia instructions for your vehicle.



Before using the “Remote engine start-up” function, check that the vehicle is immobilised (please refer to the “Parking brake” paragraph in Section 2).

**Risk of accident and serious injury.**

## STARTING, STOPPING THE ENGINE: vehicle with card (6/6)

Remote engine start performance varies according to surroundings such as:

- Obstacles, buildings, walls, other vehicles, etc.;
- radio interference (television, radio, mobile phone, other remote controller etc.);
- Condition of the key/card battery.



In the event that the function is used, please ensure that power-consuming devices (such as the wipers, exterior lights, radio, heated seats, heated steering wheel, etc.) are deactivated and all accessories are disconnected before leaving the vehicle.

**Fire hazard.**

The remote engine start-up operates if:

- the lever is in neutral for vehicles with a manual or sequential gearbox;
- the lever is in position **P** for vehicles with an automatic gearbox;
- the ignition is switched off;
- the bonnet is closed;
- all of the opening elements (doors and luggage compartment) are closed and locked when you leave the vehicle;
- in extreme weather conditions, the remote engine start-up by programming may not work.

If one of these conditions is not met, the lights will flash for approximately 3 seconds.



Do not use the engine remote start-up function or its programming when:

- the vehicle is in a garage or in a confined space.

**Risk of poisoning or suffocation by exhaust gas emissions.**

- the vehicle is covered with a protective cover.

**Fire hazard.**

- the bonnet is open or before it opens.

**Risk of burns or serious injury.**

**Depending on the country, the remote start function or its programming may be prohibited by law and/or by the regulations in force.**

**Before using this function, check the legislation and/or the regulations in force for the country.**

## FUNCTION STOP AND START (1/4)

This system enables a reduced fuel consumption and lower greenhouse gas emissions.

The system is activated automatically when the vehicle is started.

While driving, the system stops the engine (standby) when the vehicle is at a standstill (traffic jam, traffic lights, etc).

### Conditions for engine standby

The vehicle has set off from where it was parked;

#### For automatic or sequential gearbox:

- The gearbox is in position **D**, **M** or **N**; and
- the brake pedal is depressed (sufficiently hard); and
- the accelerator pedal is not depressed; and
- the vehicle's speed is zero for around one second.

The engine remains on standby if position **P** is selected, or if position **N** is selected with the handbrake engaged and the brake pedal released.

#### For manual gearboxes:

- the gearbox is in neutral; and
- the clutch pedal is released;

If the warning light  flashes, this means that the clutch pedal is not sufficiently released; and

- the vehicle speed is less than approximately 7 mph (3 km/h).

#### For all vehicles:

The warning light  on the instrument panel is lit when the engine is on standby. The vehicle equipment remains operational while the engine is stopped.

When the engine switches to standby, the steering assistance may no longer be operational.

In this case it becomes operational again when the engine is no longer on standby or the speed exceeds approximately 1 mph (1 km/h) (downhill, slope etc.).

If the engine stalls while the system is in operation, pressing the clutch pedal right down will start it again.



Before leaving the vehicle, the engine must be stopped and not put on standby (please see the information on "Starting, stopping the engine" in Section 2).



Keep your vehicle stationary when the engine is on standby (shown by the warning light  on the instrument panel).

## FUNCTION STOP AND START (2/4)

### Preventing the engine from standing by

In certain situations, such as negotiating a crossroads for instance, it is possible (with the system activated) to keep the engine running so as to be ready to move off quickly.

#### Automatic gearbox

Keep the vehicle stationary without pressing too hard on the brake pedal.

#### Manual gearbox

Keep the clutch pedal pressed right down.

To fill up with fuel, the engine must be stopped (and not only on standby in the case of vehicles equipped with the STOP and START) function: you must switch off the ignition. Please refer to the information on “Starting, stopping the engine” in Section 2.

**Fire hazard.**

### Conditions for coming out of engine standby

#### For automatic gearboxes:

- The brake pedal is released, position **D** or **M** engaged or,
- the brake pedal is released with the gear lever in position **N** and the handbrake off, or,
- the brake pedal is pressed again, with position **N** engaged and the handbrake applied, or,
- position **R** is engaged, or
- the accelerator pedal is depressed or,
- in manual mode, the gear lever is moved to **+** or **-**.

#### For manual gearboxes:

- The gearbox is in neutral and the clutch pedal is slightly depressed, or
- the engine is in gear and the clutch pedal is pressed right down.



Deactivate the Stop and Start function for any operation performed in the engine compartment.

**Special note:** depending on the vehicle, if you switch off the ignition when the engine is on standby, the warning

light  is displayed for a few seconds on the instrument panel.

If the engine stalls while the system is in operation, pressing the clutch pedal right down will start it again.



## FUNCTION STOP AND START (3/4)

### Conditions preventing the standby of the engine

Certain conditions prevent the system from using the engine standby function, including when:

#### For vehicles equipped with a card:

- the driver's door is not closed;
- the driver's seatbelt is not fastened;

#### For all vehicles:

- reverse gear is engaged;
- the bonnet is not locked;
- the outdoor temperature is too low or too high;
- the battery is not sufficiently charged;
- If available, the vehicle is in "4WD Lock" mode (please see the section "Transmission: 4-wheel drive (4WD)" in Section 2);
- the difference between the vehicle interior temperature and the automatic climate control instruction is too high;
- the altitude is too high;

- parking distance control is in operation;
  - for vehicles with automatic gearboxes, the gradient is steeper than approximately 12%;
  - the "Clear View" function is activated (please see "Automatic Climate Control" in Section 3);
  - the engine temperature is too low;
  - the emission control system is being regenerated;
- or
- ...

The warning light  appears on the instrument panel to indicate that engine standby is not available.

### Special cases for vehicles with a card

With the engine on standby (traffic jam, traffic lights, etc.), if the driver unfastens the seat belt and opens the driver's door, or gets out of the seat, the ignition is switched off.

To restart and reactivate the Stop and Start system, start the engine (please refer to the information on "Starting, stopping the engine" in Section 2).

### Special cases of vehicles with a key

With the engine on standby (traffic jam, traffic lights, etc.), if you get out of the vehicle, a beep warns you that the engine is on standby and has not been stopped.

## FUNCTION STOP AND START (4/4)

### Special feature of the automatic engine re-start

Under certain conditions, the engine can restart on its own in order to guarantee your safety and comfort.

This can occur especially when:

- the outdoor temperature is too low or too high;
- the “Clear View” function is activated (please see “Automatic Climate Control” in Section 3);
- the battery is not sufficiently charged;
- the vehicle speed is above 3 mph (5 km/h) (downhill slope, etc.);
- repeated pressing on the brake pedal or braking system requirement;
- ...

#### For vehicles equipped with a manual gearbox

The restart may be interrupted if the clutch pedal is released too quickly while a gear is engaged.



### Deactivating, activating the function

Press **1** to deactivate the function. The warning light above switch **1** lights up.

Pressing again will reactivate the system. The warning light above switch **1** goes out.

**Special note:** with the engine on standby, press switch **1** to automatically restart the engine.

The system is automatically reactivated each time the vehicle is started (see “Starting, stopping the engine” in Section 2).

### Operating faults

When the message “Check Stop & Start” appears on the instrument panel and the warning light above switch **1** appears, the system is deactivated.

Please consult an authorised dealer.

**Special feature of vehicles with a key:** for some of these conditions the automatic restarting of the engine is inhibited if a front door is open.



Before leaving the vehicle, the engine must be stopped and not put on standby (please see the information on “Starting, stopping the engine” in Section 2).

## SPECIAL FEATURES OF PETROL VERSIONS (1/2)

The following operating conditions:

- driving for long periods when the low fuel level warning light is lit;
- using leaded petrol;
- using oil or fuel additives which are not approved by the manufacturer.

Or operating faults such as:

- faulty ignition system, running out of fuel or disconnected spark plugs resulting in the engine misfiring or cutting out when driving;
- loss of power,

as they may cause the catalytic converter to overheat and thus reduce its efficiency, **or damage it irreparably and cause heat damage to the vehicle.**

If you notice any of the above operating faults, have the necessary repairs carried out as soon as possible by an approved Dealer.

These faults may be avoided by regularly taking your vehicle to your approved dealer at the intervals specified in your Maintenance Service Document.

### Starting problems

To avoid damaging the catalytic converter or the starter, and to prevent premature wearing of the battery, **do not keep** trying to start the engine (using the start button, or by pushing or towing the vehicle) **without having identified and corrected the starting fault.**

If the fault cannot be identified, do not continue to try and start the engine, but contact an approved dealer.



Do not park the vehicle or run the engine in locations where combustible substances or materials such as grass or leaves can come into contact with a hot exhaust system.

## SPECIAL FEATURES OF PETROL VERSIONS (2/2)

### Particle filter

The particle filter is used in the treatment of exhaust gases from petrol engines.

Depending on the vehicle, the warning

light  displayed on the instrument panel indicates that the filter is becoming clogged and requires cleaning. To

clean it, when the  warning light appears, and as traffic conditions and speed limits allow, drive at between about 31 mph (50 km/h) and 68 mph (110 km/h) until the light goes out.

After between approximately 5 and 20 minutes, the warning light should go out.

**Note:** The indicator light may go out after 20 minutes when the driving conditions needed to clean the filter are not completely met.

If the vehicle is stopped before the warning light disappears you will have to restart the process from the beginning.

If the filter becomes saturated, the  warning light and, depending

on the vehicle, the  warning light will appear on the instrument panel, accompanied by the message "Check Vehicle". In this case, please consult an Authorised Dealer.

If the **STOP** warning light and, depend-

ing on the vehicle, the  warning light appears, accompanied by the "Engine failure hazard" message, stop the vehicle, switch off the engine and contact an Approved Dealer.





Warning light **STOP** requires you to stop immediately, for your own safety, as soon as traffic conditions allow. Switch off the engine and do not restart it. Contact an approved Dealer.

## SPECIAL FEATURES OF DIESEL VERSIONS: PARTICLE FILTER (1/2)

### Diesel engine speed

Diesel engines are fitted with an injection pump **which prevents the engine speed being exceeded** irrespective of the gear selected.

If the message “Check Anti- Pollution System” is displayed along with warn-

ing lights  and , consult an authorised dealer immediately.

When driving, depending on the fuel grade used, it is possible that white smoke may be emitted.

This is due to the exhaust particle filter being cleaned automatically, and does not affect the way the vehicle runs.

### Running out of fuel

If the tank has been **completely drained**, the system must be reprimed after the tank is refilled: See “Fuel tank” in section 1 before restarting the engine.

43214

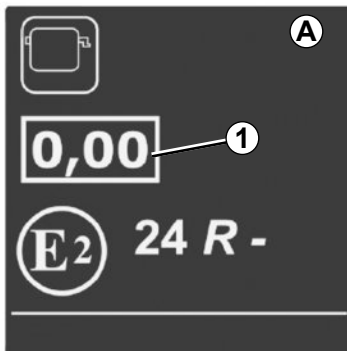

### Engine smoke opacity label

You can find the information **1** on the label **A** stuck in the engine compartment or, depending on the vehicle, on the vehicle identification plate. Refer to the “Vehicle Identification plate” paragraph in Section 6.

**1** Diesel exhaust emissions.

### Precautions to be taken in winter

To avoid any faults in icy weather:

- ensure that the battery is always fully charged;
- always keep the diesel tank relatively full to avoid water vapour condensing in it and accumulating at the bottom of the tank.



Do not park the vehicle or run the engine in locations where combustible substances or materials such as grass or leaves can come into contact with a hot exhaust system.

## SPECIAL FEATURES OF DIESEL VERSIONS: PARTICLE FILTER (2/2)

### Particle filter

The particle filter is used to treat of exhaust gases from diesel engines.

Depending on the vehicle, the warning

light  displayed on the instrument panel indicates that the filter is becoming clogged and requires cleaning.

To do this, when the  warning light is displayed, continue driving according to traffic conditions and observe the speed limit until the warning lights disappears. If possible, do not let the engine speed drop below 2000 rpm.

After between approximately 10 and 20 minutes, the warning light should go out.



The display of the  on the instrument panel may be accompanied by an increase in engine speed and operation of the cooling system in order to clean the particle filter.

**Note:** the warning light may reappear if the driving conditions are not fully met with regard to cleaning the filter. If the vehicle is stopped or if the engine speed drops below 2,000 rpm before the warning light goes out, the operation may need to be repeated.

To facilitate the particle filter regeneration, carry out a long driving phase (at least 20 minutes) on main roads every 124 miles (200 km).

If the filter becomes saturated, the  warning light and, depending

on the vehicle, the  warning light will appear on the instrument panel, accompanied by the message “Check injection”. In this case, please consult an Authorised Dealer.

If the  warning light and, depending on the vehicle, the  warning light appears, accompanied by the “WARNING: Engine Failure Risk” message, stop the vehicle, switch off the engine and contact an Approved Dealer.



Warning light  requires you to stop immediately, for your own safety, as soon as traffic conditions allow. Switch off the engine and do not restart it. Contact an approved Dealer.

# SPECIAL FEATURES OF LPG VERSIONS (1/4)

## LPG vehicles

These vehicles use two types of fuel (LPG and petrol) for bi-fuel operation. They are fitted with two separate tanks, please refer to the “Fuel Tank” paragraph in Section 1.

## What is LPG?



Liquefied petroleum gas that complies with standard EN 589, or the equivalent national regulations.

It can be readily identified by its characteristic smell.



An LPG installation on a vehicle may lead to changes to the vehicle's features, compared to petrol versions. This may relate to the number of seats, mass (usable capacity) and towing capacity.

Consult your approved Dealer.

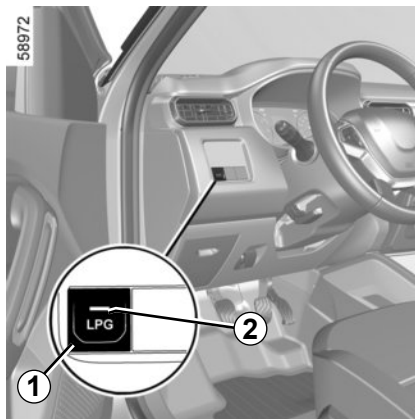

## LPG/petrol fuel mode selection control 1

This enables the driver to manually switch from one fuel mode to another.

## Green warning light 2

Rapid flashing of the warning light 2 indicates that the system is waiting for the necessary conditions to switch to LPG mode.

The constant warning light 2 indicates that LPG mode is activated.

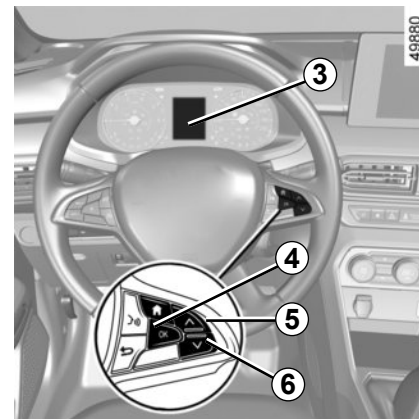

## Fuel gauge warning light

The display 3 indicates the LPG tank level.

The amount of LPG indicated is an indicative value.

The message “LPG low level” is displayed on the trip computer 3 accompanied by a beep to indicate that the tank is almost empty and the engine is running on the fuel reserve.

Press one of the switches 4 “OK”, 5 or 6 to discard the message.

## SPECIAL FEATURES OF LPG VERSIONS (2/4)

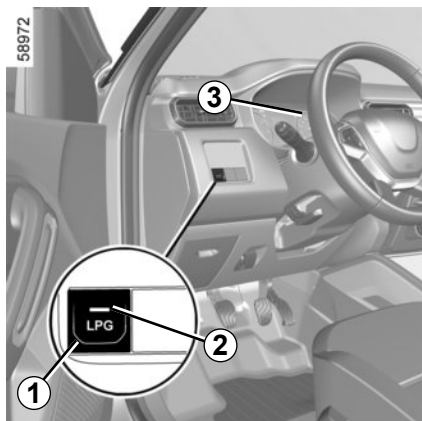

### Starting the engine

The engine is always started using petrol.

- For vehicles with a key, please refer to the “Starting, stopping the engine: vehicle with a key” paragraph in Section 2;
- For vehicles with a card, please refer to the “Starting, stopping the engine: vehicle with a card” paragraph in Section 2.

**Note:** if LPG mode is active when the engine is started, the system temporarily switches to “petrol” mode: the green warning light **2** goes out without a beep and the display **3** indicates that petrol mode is activated.

As soon as the environmental conditions are met (engine temperature level, etc.), the system automatically switches to LPG mode: the green warning light **2** is switched on permanently.

To access the information and to reset the LPG trip parameters, see the “Trip computer: trip settings” paragraph in Section 1.

### Changing fuel while driving

#### To switch from petrol mode to LPG mode manually

Press the button **1**.

The transition to LPG is made during the first acceleration:

- the LPG fuel level is activated on the display **3**;
- the green warning light **2** flashes quickly to confirm that LPG mode has been selected, then stops flashing when LPG mode is activated.

#### To switch from LPG mode to petrol mode manually

Release the accelerator pedal and press the control **1**.

The warning light **2** goes out and the display **3** indicates that petrol mode is activated.



## SPECIAL FEATURES OF LPG VERSIONS (3/4)

### Automatically switching from LPG mode to petrol mode

Depending on the vehicle, under certain conditions of use, the system may opt to temporarily switch back to petrol mode.

Once the suitable conditions are present once again, it will automatically switch back to LPG mode.

**Note:** after several unfruitful attempts, the system may decide to remain in petrol mode for the current journey. A new attempt may be made after the engine has been stopped completely for about one minute.

**While the fuel tank is empty, the vehicle cannot start or drive in LPG mode only.**

Bi-fuel operation using LPG/petrol requires the presence of petrol (for starting, high acceleration, cold temperatures, etc.).

If the orange warning light  appears on the instrument panel and a beep sounds, fill the tank with fuel as soon as possible.

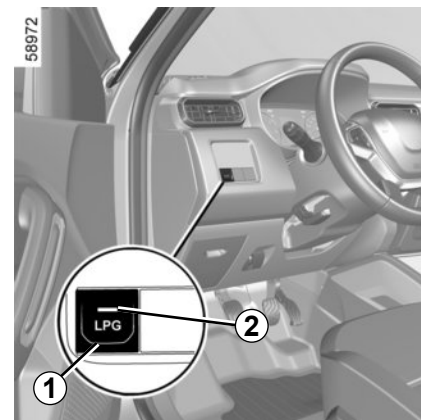

### LPG tank empty

If there is no more LPG remaining in the tank then the system automatically switches to petrol mode.

To inform the driver, the warning light **2** disappears from the display. Fill up with LPG, refer to the “Fuel tank” paragraph in Section 1.

## SPECIAL FEATURES OF LPG VERSIONS (4/4)

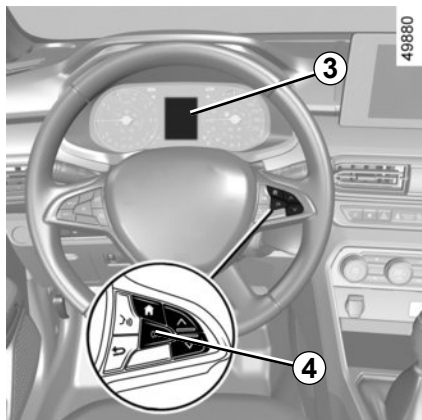

### Operating faults

In the event of a fault which may affect the correct operation of the engine, the system automatically switches from LPG to petrol mode.

This is confirmed once the message “Check LPG injection” appears on the instrument panel 3.

Press the 4 “OK” switch to discard the message, then contact an approved dealer to carry out a check.

### If driving under severe conditions

**In very cold weather** (temperature below approximately 10°C) and depending on the quality of the gas used, the system may automatically manage the conditions for switching between LPG mode and petrol mode.

**Note:** for vehicles that are equipped, it is recommended that you use the ECO mode in these conditions (particularly below 0°C) in order to maximise the use of LPG mode (please refer to the “Driving advice, Eco-driving” paragraph in Section 2).

### In the event of an accident

The main precautions to be taken are the same as with petrol vehicles:

- apply the handbrake;
- stop the engine (a safety device that stops LPG from entering the engine is automatically triggered);
- switch off the ignition;
- observe local regulations.



LPG has a very specific smell so you will be able to detect any leaks easily. If you smell gas in your vehicle or immediately surrounding your vehicle:

- switch to petrol mode immediately and make sure there are no flames or sources of fire near the vehicle;
- go to an authorised dealer.



Do not touch, hit or dismantle any part of the LPG system components.

## DRIVING ADVICE, ECO-DRIVING (1/5)

Fuel consumption is accredited in accordance with a standard regulatory method. Identical for all manufacturers, this enables vehicles to be compared with one another. Consumption in real time depends on vehicle usage conditions, the equipment fitted and the user's driving style. To optimise fuel consumption, please refer to the following advice.



Depending on the vehicle, you will have various functions which enable you to lower your fuel consumption:

- the rev counter;
- gear change indicator;
- **ECO** mode activated by the **ECO** button;
- the **Stop and Start** (refer to the information on “**Stop and Start** function” in Section 2).



### Gear change indicator 1

To optimise consumption levels, a warning light on the instrument panel **A** or **B** indicates the best time to move up or down a gear:

-  upshift a gear;
-  move down a gear.

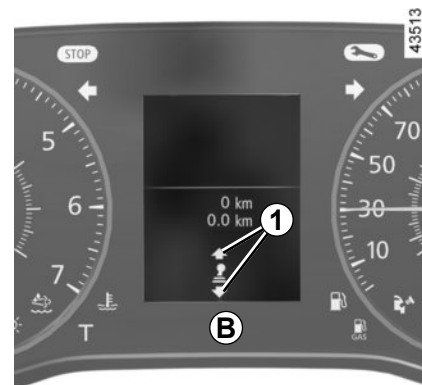

## DRIVING ADVICE, ECO-DRIVING (2/5)



### ECO mode

**ECO** mode is a function which optimises fuel consumption. It acts on certain power consuming systems in the vehicle (heating, air conditioning, power-assisted steering, etc.) and on certain driving actions (acceleration, gear changing, cruise control, deceleration, etc.).

Limiting acceleration enables low fuel consumption in urban and surrounding areas. When **ECO** mode is in use, it is normal for changes in the heating level to occur.

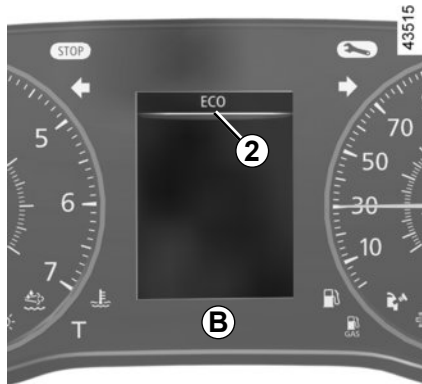

### Activating the function

Press switch **3**.

The **2 ECO** warning light comes on the instrument panel **A** or **B** to confirm activation.

While driving, it is possible to leave the **ECO** mode temporarily in order to improve engine performance.

To do this, press the accelerator pedal firmly and fully.

**ECO** mode is reactivated when you take pressure off the accelerator pedal.

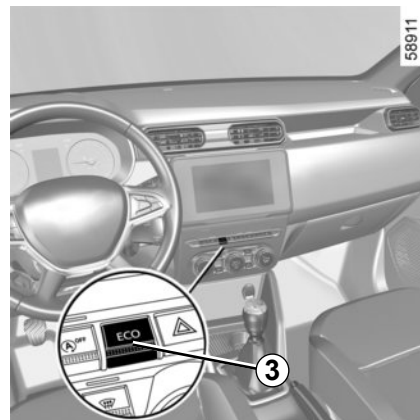

### Disabling the function

Press switch **3**.

The **2 ECO** light goes out on the instrument panel to confirm deactivation.

## DRIVING ADVICE, ECO-DRIVING (3/5)

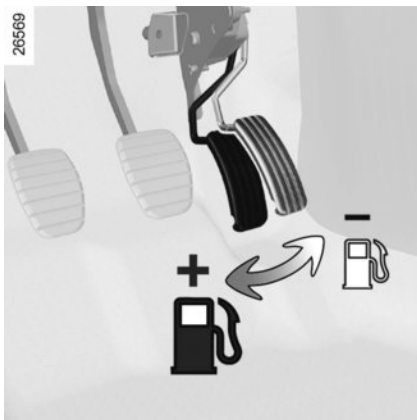

### Driving advice and ECO driving

#### Behaviour

- Drive carefully for the first few miles until the engine reaches its normal operating temperature, rather than let it warm up while the vehicle is stationary.

Vehicles with 4x4 (4WD) transmission

- High speeds significantly affect the vehicle's fuel consumption.

Examples (at a steady speed):

- reducing the speed from 80 mph (130 km/h) to 68 mph (110 km/h) approximately allows you to save up to around 20% of fuel;
- reducing the speed from 56 mph (90 km/h) to 50 mph (80 km/h) approximately allows you to save up to around 10% of fuel.
- Sporty driving uses a lot of fuel: drive with a light right foot.



#### Driving problems

On the driver's side, only use mats suitable for the vehicle, attached with the pre-fitted components, and check the fitting regularly. Do not lay one mat on top of another.

#### Risk of pedals jamming.

- Do not overrev the engine in the intermediate gears. You should always use the highest gear possible.

- Avoid sudden acceleration.
- Brake as little as possible. If you anticipate an obstacle or bend in advance, you may then simply release the accelerator pedal.
- Do not try to maintain the same speed up a hill, accelerate no more than you would on the level. Keep your foot in the same position on the accelerator pedal.
- Double declutching and accelerating before switching off are unnecessary in modern vehicles.

On versions with an automatic gearbox, it is preferable to keep the gear lever in position **D**.

#### Heating levels

It is normal to notice an increase in the vehicle's fuel consumption when using the heating (particularly when the outside temperature drops below zero) or air conditioning.

## DRIVING ADVICE, ECO-DRIVING (4/5)

Ⓒ

36496

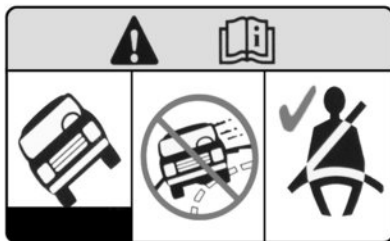

The label **C** in the vehicle informs you that your vehicle has a higher ground clearance than an ordinary passenger vehicle. This gives it a higher centre of gravity, making it more susceptible to overturning in the event of sudden or aggressive manoeuvres or when cornering sharply at high speeds.

Take extra care when the vehicle is loaded (in particular when the load is on the roof).

Ensure that all passengers are wearing their seat belts.



**4x2 (2WD)** versions

The vehicle must not be used in off-road mode.

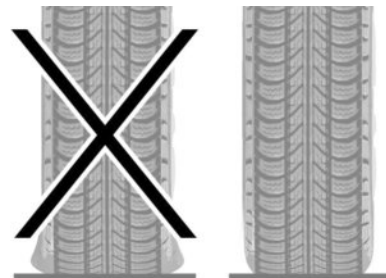

26528



### Tyres

- An underinflated tyre increases fuel consumption.
- The use of non-recommended tyres can increase fuel consumption.

## DRIVING ADVICE, ECO-DRIVING (5/5)

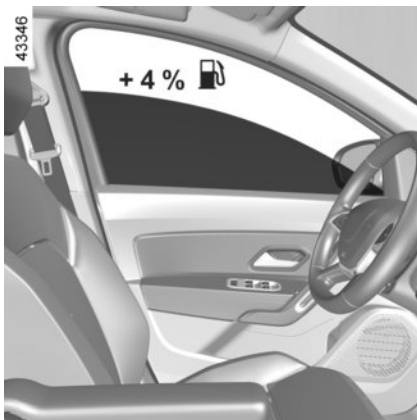

### Advice on use

- Favour the **ECO** mode.
- Electricity is fuel; switch off all the electrical components which are not really needed. **However** (safety first), keep your lights on when the visibility is bad (“see and be seen”).
- Use the air vents. Driving with the windows open at 60 mph (100 km/h) will increase fuel consumption by 4%.
- Never fill the fuel tank right to the brim to avoid overflow.

- On vehicles equipped with non-automatic air conditioning, switch off the air conditioning when it is not required.

### Suggestions for reducing consumption and therefore helping to preserve the environment:

- If the vehicle has been parked in the sun, open the doors for a few moments to let the hot air escape before starting the engine.
- Do not leave an empty roof rack fitted to the vehicle.
- It is better to fit a trailer for bulky objects.
- When towing a caravan, fit a wind deflector and adjust it carefully.
- Avoid using the car for door-to-door calls (short journeys with long waits in between) because the engine never reaches its normal operating temperature.

# MAINTENANCE AND ANTIPOLLUTION ADVICE

Your vehicle complies with criteria for recycling and recovering vehicles at the end of their service life, which entered into force in 2015.

Some of the parts on your vehicle have been designed to be recycled later. These parts are easily removable in order to be collected and reprocessed in recycling networks.

Furthermore, by virtue of its design, moderate fuel consumption and initial settings, your vehicle also conforms to current anti-pollution regulations. The manufacturer is actively striving to reduce pollutant exhaust gas emissions and to save energy. However, the fuel consumption of your vehicle and the level of pollutant exhaust gas emissions are also your responsibility. Ensure that it is maintained and used correctly.

## Maintenance

It is important to remember that failure to respect antipollution regulations could lead to legal action being taken against the vehicle owner.

In addition, replacing engine, fuel supply system and exhaust components with parts other than those originally recommended by the manufacturer may alter your vehicle so that it no longer complies with anti-pollution regulations.

Have your vehicle adjusted and checked by an authorised dealer, in accordance with the instructions given in your maintenance schedule: they will have all the equipment necessary for ensuring that your vehicle is maintained to its original standard.

## Engine adjustments

– **Spark plugs:** for optimum conditions of use, output and performance the specifications laid down by our Design Department must be strictly applied.

If the spark plugs have to be changed, use the make, type and gap specified for your vehicle's engine. Contact an authorised dealer for this.

- **Air filter, fuel filter:** a choked element will reduce efficiency. It must be replaced.
- **Ignition and idle speed:** no adjustment is needed.

## Exhaust gas monitoring system

The exhaust gas monitoring system will detect any operating faults in the vehicle's antipollution system.

If this system malfunctions, toxic substances may be released into the atmosphere or damage may occur.



This warning light on the instrument panel will indicate if there are any faults in the system: This lights up when the ignition is switched on and goes out when the engine is started.

- If it lights up continuously, consult an approved Dealer as soon as possible;
- if it flashes, reduce the engine speed until the light stops flashing. Contact an authorised dealer as soon as possible.



Refer to the information on "Reagent tank" in Section 1.



## ENVIRONMENT

Your vehicle has been designed with respect for the **environment** in mind for its entire service life: during production, use and at the end of its life.

### Manufacture

Your vehicle has been manufactured at a factory which complies with a policy to reduce the environmental impact on the surrounding areas (reduction of water and energy consumption, visual and noise pollution, atmospheric emissions and waste water; sorting and re-using waste).

### Emissions

Your vehicle has been designed to emit fewer greenhouse gases (CO<sub>2</sub>) while in use, and therefore to consume less fuel (eg. 140 g/km, equivalent to 5.3 l/100 km for a diesel vehicle).

Our vehicles are also equipped with a particle filter system including a catalytic converter, an oxygen sensor and an active carbon filter (the latter prevents vapour from the fuel tank being released into the open air).

For certain diesel vehicles, this system also has a particle filter to reduce the volume of soot particles emitted.

### Please make your own contribution towards protecting the environment too

- Worn parts replaced in the course of routine vehicle maintenance (vehicle battery, oil filter, air filter, batteries, etc.) and oil containers (empty or filled with used oil) must be disposed of through specialist organisations.

- At the end of the vehicle's service life, it should be sent to approved centres to ensure that it is recycled.
- In all cases, comply with local legislation.

### Recycling

Your vehicle is 85% recyclable and 95% recoverable.

To achieve these objectives, many of the vehicle components have been designed to enable them to be recycled. The materials and structures have been carefully designed to allow these components to be easily removed and reprocessed by specialist companies.

In order to preserve raw material resources, this vehicle incorporates numerous parts made from recycled plastics or renewable materials (vegetable or animal-derived materials such as cotton or wool).

# TYRE PRESSURE LOSS WARNING (1/4)

43592

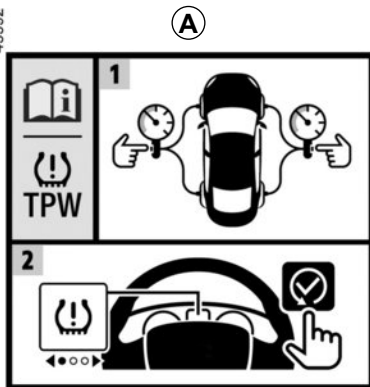

If the vehicle is equipped, this system detects a loss of pressure in one of the tyres by measuring the wheel speed while driving.

The system is fitted if there is a **A** label in the vehicle. To check if it is there, open the driver's door, location **1**.

43406



## Operating principle

This system detects a loss of pressure in one of the tyres by measuring the wheel speed while driving.

The warning light  **2** stays on and, depending on the vehicle, is accompanied by the message "Inflate tyres and init." is displayed to alert the driver in the event of insufficient pressure (deflated wheel, punctured tyre etc.).

43353

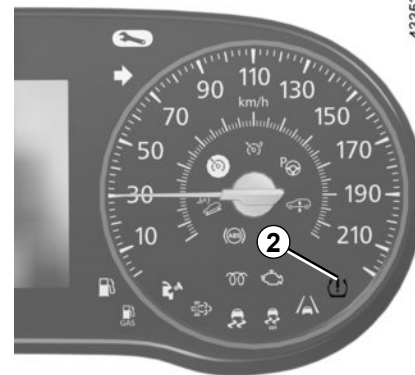

## TYRE PRESSURE LOSS WARNING (2/4)

### Operating conditions

The system has to be reset with an inflation pressure equal to that written on the tyre inflation pressure label. Otherwise it risks not giving a reliable warning in the event of a significant loss of pressure. Please refer to the information on “Tyre pressures” in Section 4.

In the following situations, the system risk coming into action late or not functioning correctly:

- system not reset after reinflation or any operation on the wheels;
- system badly reset: different inflation pressures from the recommended pressures;
- significant change in load or distribution of load on one side of the vehicle;
- sporty driving with strong acceleration;
- driving on snowy or slippery surface;
- driving with snow chains;

- fitting a single new tyre;
- use of tyres not approved by the network;
- ...



This function is an additional driving aid.

The function does not take the place of the driver. It cannot, therefore, under any circumstances replace the vigilance or the responsibility of the driver.

Check the tyre pressures, including the emergency spare wheel, once a month.

### Resetting the standard level for the tyre pressures

This should be done:

- after each reinflation or readjustment of the pressure of one of the tyres;
- when the standard tyre pressure needs to be changed to adapt to usage conditions (empty, carrying a load, motorway driving, etc.);
- after changing a wheel;
- after using the tyre inflation kit;
- after changing wheels around.

It should always be done after checking the tyre pressure of all four tyres when cold.

Tyre pressures must correspond to the current usage of the vehicle (empty, carrying a load, motorway driving, etc.).

## TYRE PRESSURE LOSS WARNING (3/4)

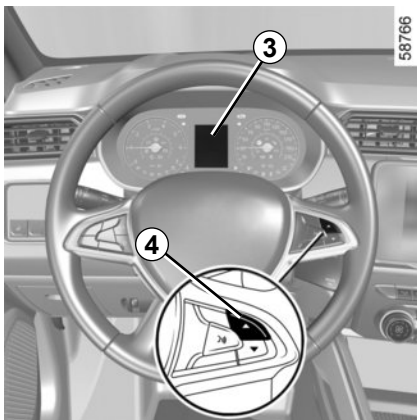

### Resetting procedure

Ignition on, vehicle stationary:

- repeatedly press the button **4** briefly and the “Recalibrate SET TPW” message or, depending on the vehicle, the “Check tyre press and init.” message is displayed on the instrument panel **3**;

- press and hold (around 3 seconds) the button **4** to start initialisation. Flashing, for around five seconds, followed by a constant display of the “SET TPW launched” message or, depending on the vehicle, the “Operation completed” message indicates that the tyre pressure reference value reset request has been taken into account.

Reinitialisation is carried out after a few minutes' driving.

The sudden loss of pressure in a tyre (burst tyre, etc.) cannot be detected by the system.

### Display

#### Inflate tyres

The warning light  comes on (not flashing).

This indicates that at least one tyre is flat or punctured.

In the event of a flat tyre, inflate the relevant tyre.

In the event of a puncture, change the tyre or consult an authorised dealer.

Check and readjust the pressure of the four tyres when cold, and launch the reset of the tyre pressure reference value.

Warning light  goes out after launching the reinitialisation of the tyre pressure reference value.



For your safety, the warning light **STOP** requires you to stop immediately as soon as traffic conditions allow.

## TYRE PRESSURE LOSS WARNING (4/4)

### Restart the resetting of the tyre pressures

Warning light  flashes for several seconds, then stays on.



It indicates that the request to reset the reference tyre pressure value must be relaunched.

### System unavailable

The warning light  flashes for several seconds then stays on, and, depending on the vehicle, the “Check TPW” message is displayed on the instrument panel.

Indicates that the vehicle is fitted with an emergency spare wheel which is smaller than the other four and is fitted to the vehicle.

### System to be checked

The warning light  flashes for several seconds, then stays on, along with the orange warning light .

They indicate a system fault. Please consult an authorised dealer.

### Readjustment of tyre pressures

**The tyre pressures must be adjusted when cold** (please refer to the label located on the edge of the driver's door).

If tyre pressures cannot be checked when the tyres are **cold**, the recommended pressures should be increased by **0.2** to **0.3** bar (3 PSI).

### Never deflate a hot tyre.

After each reinflation or readjustment of the tyre pressure, launch the reinitialisation of the tyre pressure reference value.

### Replacing wheels/tyres

Only use equipment approved by the brand network, or the system risks being activated late or not operating correctly. Please see the information on “Tyres” in Section 5.

After each change of wheel/tyre, readjust the tyre pressure and launch the reset of the tyre pressure reference value.

### Emergency spare wheel

If fitted on the vehicle, readjust the tyre pressure and launch the reinitialisation of the tyre pressure reference value.

### Inflation kit

Only use equipment approved by the brand network, or the system risks being activated late or not operating correctly. Please refer to “Tyre inflation kit” in Section 5.

After using the tyre inflation kit, readjust the tyre pressure and launch the reinitialisation of the tyre pressure reference value.

# GEAR LEVER / HANDBRAKE

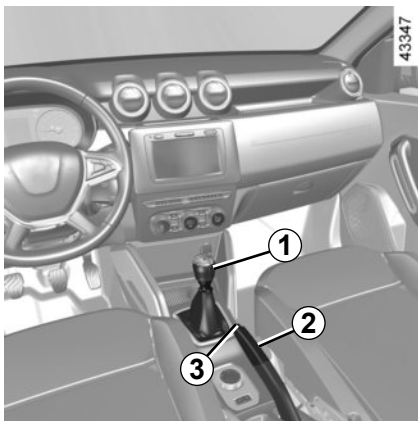

## Gear lever

### Selecting reverse gear (vehicle stationary)

**Vehicles with a manual gearbox:** follow the grid pictured on the knob **1** and lift the ring against the gear lever knob to select reverse.

**Vehicles with automatic gearbox:** refer to the information on the "Automatic gearbox" in Section 2.

The reversing lights will come on as soon as reverse gear is selected with the ignition on.

## Handbrake

### To release

Pull lever **2** up slightly, press button **3** and then lower the lever to the floor.

The indicator light  on the instrument panel goes off.

The red warning light on the instrument panel will come on if you are driving with an incorrectly released handbrake.



An impact to the underside of the vehicle (eg. striking a post, raised kerb or other street furniture) may result in damage to the vehicle (eg. deformation of an axle).

To prevent any risk of accident, have your vehicle checked by an approved dealer.

### To apply

Pull lever **2** upwards and make sure the vehicle is immobilised.

The warning light  on the instrument panel will come on.



Make sure that the handbrake is properly released when driving (red indicator light off), otherwise overheating, or even damage, may occur.



When stationary, and depending on the slope and/or vehicle load, it may be necessary to pull up the handbrake at least two extra notches and engage a gear (1<sup>st</sup> or reverse gear) for vehicles with a manual gearbox or position **P** for vehicles with an automatic gearbox.

## TRANSMISSION: 4-wheel drive (4WD) (1/5)

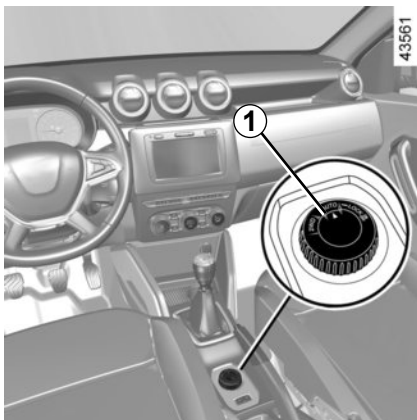

Remember that driving a vehicle off-road is very different to driving it on the road.

Adapt the driving style to the mode selected (4x2, 4x4, Auto).

The safety of both you and your passengers is your responsibility, and depends on your skill and the care you take when driving.

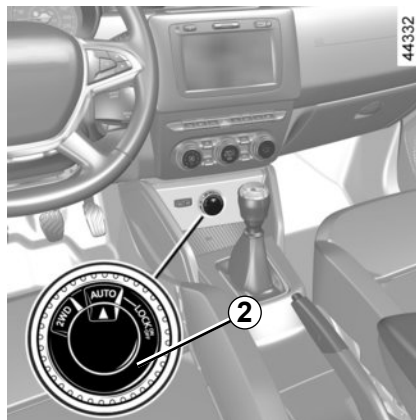

### 4x2 (2WD) and 4x4 (4WD) mode selector

Depending on the road conditions, turn the selector **1** or, depending on the vehicle, the selector **2** to select one of the following modes:

- 2WD;
- AUTO;
- 4WD Lock.

### “AUTO” mode

To activate this mode, turn the selector **1** or, depending on the vehicle, **2** to the **AUTO** position.

### Operating principle

“AUTO” mode automatically distributes the engine torque between the front and rear axles according to the road conditions and the vehicle speed. This position optimises roadholding. Use this mode on any type of road (dry, snow-covered, slippery, etc.) or when towing (trailer or caravan). This mode is not indicated on the instrument panel.

## TRANSMISSION: 4-wheel drive (4WD) (2/5)

### “2WD” mode

To activate this mode, turn the selector **1** or, depending on the vehicle, selector **2** to the 2WD position. Warning

light **2WD** comes on the instrument panel.

#### Operating principle

The “2WD” mode uses the front wheels only. Use this mode on dry roads with good grip.

To deactivate this mode, turn the selector **1** or, depending on the vehicle, **2** to

the AUTO position. Warning light **2WD** goes out on the instrument panel.

### “4WD Lock” mode

To activate this mode, turn the selector **1** or, depending on the vehicle, **2** to the 4WD Lock position. The selector returns to the “AUTO” position.

Warning light **4WD LOCK** comes on the instrument panel.

#### Operating principle

“4WD Lock” mode distributes the engine torque between the front and rear axles in order to optimise the performance capacity of the vehicle in off-road situations. This mode should only be used in extreme driving conditions (mud, steep slopes, sand).

To deactivate this mode, turn the selector **1** or, depending on the vehicle, **2** to the 4WD Lock position again. The warning light on the instrument panel goes out. When the engine is stopped, 4WD Lock mode stays on for one minute.

After one minute, the system switches to “2WD” or “AUTO” mode depending on the position of the selector.

**Note:** if the vehicle is travelling at a speed of more than approximately 50 mph (80 km/h) or if it travels at a speed of between 37 and 50 mph (60 and 80 km/h) for more than one minute in “4WD Lock” mode, the system automatically switches back to “AUTO” mode. Warning light **4WD LOCK** goes out.



## TRANSMISSION: 4-wheel drive (4WD) (3/5)

### Special features of the 4-wheel drive transmission

The vehicle may make more noise when the "AUTO" or "4WD Lock" modes are activated. This is normal. If the system detects a difference in the dimensions of the front and rear wheels (eg. underinflation, severe wear on an axle), the system automatically switches to "2WD" mode.

The  warning light lights up and, depending on the vehicle, the message "Check 4WD" appears on the instrument panel. Drive as soon as possible at a moderate speed to an approved dealer.

This problem may be resolved by changing the tyres. Always use four identical tyres (same brand, profile, etc.) and with similar wear.

In the event of excessive wheelspin, the mechanical components may be overheating.

If this happens:

- at first, the warning light  lights up and, depending on the vehicle, the message "4WD Overheating" is displayed on the instrument panel. 4WD Lock mode is still active – however, we recommend that you stop as soon as possible to allow the system to cool down;
- if the wheels still spin, the system automatically switches to "2WD" mode to protect the mechanical components.

The  warning light lights up and, depending on the vehicle, the message "4WD Overheating" appears on the instrument panel.

In this case, it is recommended that you stop as soon as possible to allow the system to cool down.

Cooling may take up to five minutes.

If the system detects excessive wheelspin on the front wheels, it adapts the engine to run in a way that reduces wheelspin.

## TRANSMISSION: 4-wheel drive (4WD) (4/5)

### Anti-lock braking in “LOCK” mode (vehicles equipped with ABS)

When “4WD Lock” mode is active, the ABS switches to off-road mode. In this case, the wheels may lock intermittently to achieve better grip, thus reducing braking distances on soft ground. When this mode is active:

- the vehicle’s manoeuvrability is limited during braking. This operating mode is therefore not recommended in very low-grip conditions (e.g., ice);
- there may be some noise. This is normal, and does not indicate an operating fault.

### Electronic stability program and traction control when driving off-road

(vehicles equipped with ESC)

When driving on soft ground (sand, mud, deep snow), we recommend that you deactivate the ESC function by pressing the “ESC” switch.

In this case, only individual wheel braking remains active. This function applies the brake to any wheel that is slipping, allowing the engine torque to be transferred to the wheels with the most grip. This is particularly useful when crossing a bridge.

All the ESC functions will be reactivated when the vehicle speed reaches approximately 30 mph (50 km/h) (36 mph (60 km/h) in 4WD Lock mode), when the engine is restarted or when the “ESC” button is pressed again.

### Operating faults

When the system detects an operating fault, it automatically switches to 2WD mode, the  warning light comes on and, depending on the vehicle, the message “Check 4WD” appears on the instrument panel.

Drive as soon as possible at a moderate speed to an approved dealer.

For certain operating faults, the system may not be able to switch to “2WD” or “4WD Lock” mode. “AUTO” mode remains active.

Contact an approved dealer as soon as possible.

## TRANSMISSION: 4-wheel drive (4WD) (5/5)



### All-wheel drive system

- Irrespective of the mode selected, do not start the engine if one or more wheels are not in contact with the ground (eg. when the vehicle is on a jack or roller bench).
- Do not turn the mode selector when cornering, reversing or if the wheels are spinning excessively. Only select the “2WD”, “AUTO” or “4WD Lock” mode when the vehicle is being driven in a straight line.
- Only use tyres which meet the required specifications.
- 4WD Lockmode is reserved exclusively for driving **off-road**. The use of this mode in any other conditions may adversely affect the vehicle’s manoeuvrability and damage its mechanical components.
- Always ensure tyres with identical specifications are fitted to all four wheels (brand, size, structure, wear etc.). Fitting tyres of different sizes to the front and rear wheels and/or left and right wheels may have serious consequences for the tyres, gearbox, transfer gearbox and the rear differential pinions.

## DRIVER CORRECTION DEVICES, AIDS (1/5)

Depending on the vehicle, this is composed of:

- the **ABS (anti-lock braking system)**;
- **emergency brake assist**;
- **electronic stability program ESC with understeer control and traction control**;
- **hill start assist**;
- **hill descent control**.



These functions are an additional aid in the event of critical driving conditions, enabling the vehicle behaviour to be adapted to suit the driving conditions. The functions do not take the place of the driver. **They do not increase the vehicle's limits and should not encourage you to drive more quickly.** Therefore, they can under no circumstances replace the vigilance or responsibility of the driver when manoeuvring the vehicle (the driver must always be ready for sudden incidents which may occur when driving).

### ABS (anti-lock braking system)

Under heavy braking, the ABS prevents the wheels from locking, allowing the stopping distance to be managed and keeping control of the vehicle.

Under these circumstances, the vehicle can be steered to avoid an obstacle whilst braking. In addition, this system can increase stopping distances, particularly on roads with low surface grip (wet ground etc.).

You will feel a pulsation through the brake pedal each time the system is activated. The ABS does not in any way improve the vehicle's physical performance relating to the road surface and roadholding. It is still **essential** to follow the rules of good driving practice (such as driving at a safe distance from the vehicle in front etc.).







### Special feature of 4-wheel drive vehicles

In 4WD Lock mode, the system may lock the wheels briefly to optimise the braking distance on very wet ground (snow, mud, sand, etc.).

In an emergency, apply **firm and continuous pressure** to the brake pedal. There is no need to pump it repeatedly. The ABS will modulate the force applied in the braking system.

## DRIVER CORRECTION DEVICES, AIDS (2/5)

### Operating faults:

-  and  lit up on the instrument panel accompanied by the messages “Check ABS”, “Check braking system” and “Check ESC”: this indicates that the ABS, the ESC and the emergency brake assist are disabled. **Braking is always enabled;**
- , ,  and  lit on the instrument panel accompanied by the message “WARNING: Braking System”: **this indicates a fault with the braking system.**

In both cases, consult an approved dealer.



Warning light  requires you to stop immediately, for your own safety, as soon as traffic conditions allow. Switch off the engine and do not restart it. Contact an approved Dealer.

### Emergency brake assist with electronic brake distribution

(depending on the vehicle)

This system supplements the ABS and helps reduce vehicle stopping distances.

#### Operating principle

The system is for detecting an emergency braking situation. In this case, the braking assistance immediately develops maximum power and may trigger ABS regulation.

ABS braking is maintained as long as the brake pedal is applied.



Your braking systems are partially operational. However, it is **dangerous to brake suddenly** and it is essential to stop immediately, as soon as traffic conditions allow. Contact an approved dealer.

## DRIVER CORRECTION DEVICES, AIDS (3/5)



### Electronic stability program ESC with understeer control and traction control

#### Electronic stability program ESC (depending on the vehicle)

This system helps you to keep control of the vehicle in critical driving conditions (avoiding an obstacle, loss of grip on a bend, etc.).



### Understeer control

This system optimises the action of the ESC in the case of pronounced understeering (loss of front axle road holding).

### Traction control

This system helps to limit wheelspin of the drive wheels and to control the vehicle when pulling away accelerating or decelerating.

## Deactivating the ESC function

In some situations (driving on very wet ground: snow, mud, etc. or driving with snow chains fitted), the system may reduce the engine output to limit wheelspin. If this is not required, it is possible to deactivate the function by pressing switch 1.

The warning light  appears and, depending on the vehicle, the message "ESC OFF" is displayed on the instrument panel to warn you. **If you deactivate this function, the traction control system will also be deactivated.**

With the Electronic Stability Program ESC with understeer control and traction control providing additional safety, you are advised not to drive with the function disabled. Correct this as soon as possible by pressing the switch 1 again.

**Note:** The function is automatically reactivated when the ignition is switched on, or when the speed exceeds 30 mph (50 km/h) in "AUTO" and "2WD" modes, and approximately 36 mph (60 km/h) in "4WD Lock" mode.

# DRIVER CORRECTION DEVICES, AIDS (4/5)

## Operating principle

A sensor in the steering wheel detects the direction selected by the driver.

Other sensors throughout the vehicle measure the actual direction.



The system compares driver input to the actual trajectory of the vehicle and corrects the trajectory if necessary by controlling the braking of certain wheels and/or engine power. In the event that the system is engaged, indicator light



flashes on the instrument panel.

## Operating faults

When the system detects an operating

fault, the  and  warning lights come on and, depending on the vehicle, the message "Check ESC" appears on the instrument panel. In this case, the Electronic Stability Program ESC with understeer control and traction control are deactivated.

Please consult an authorised dealer if these warning lights remain displayed on the instrument panel after the ignition is switched off and on again.

## Hill start assistance

Depending on the gradient of the incline, this system assists the driver when starting on a hill. It prevents the vehicle from rolling backwards by automatically applying the brakes when the driver lifts his/her foot off the brake pedal to depress the accelerator pedal.

## System operation

It only operates when the gear lever is in a position other than neutral (other than N or P for automatic transmissions) and the vehicle is completely stationary (brake pedal depressed).

The system holds the vehicle for approximately **2 seconds**. The brakes are then released (the vehicle will move according to the slope).

When the system detects an operating fault, the warning light  appears and, depending on the vehicle, the message "Check Hill Start Assist" is displayed on the instrument panel. Consult an approved dealer.



The hill start assistance system cannot completely prevent the vehicle from rolling backwards in all situations (extremely steep gradients etc.).

In all cases, the driver may depress the brake pedal to prevent the vehicle from rolling backwards.

The hill start assistance function should not be used for prolonged stops: use the brake pedal.

This function is not designed to immobilise the vehicle permanently.

If necessary, use the brake pedal to stop the vehicle.

The driver must remain particularly vigilant when driving on slippery or low-grip surfaces.

**Risk of serious injury.**

## DRIVER CORRECTION DEVICES, AIDS (5/5)



### Hill descent control



This function enables the vehicle speed to be limited without depressing the brake pedal (when driving down a steep hill).

The hill descent control operates between 3 and 19 mph (5 and 30 km/h).

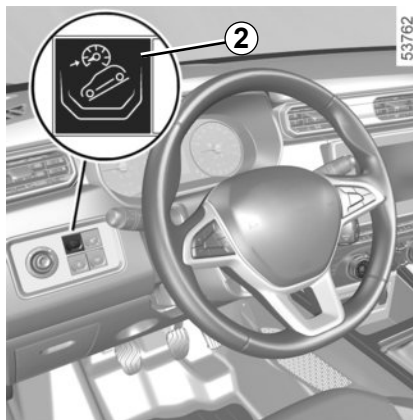
**Note:** if the vehicle speed is above 37 mph (60 km/h), the system is disabled and the  indicator light goes out.



### Activating/deactivating the system

- **Activation:** press the **2** button. The  indicator light on the instrument panel comes on.
- **Deactivation:** press the **2** button again. Warning light  goes out.

This system does not operate if the gear lever is in position **P** for vehicles fitted with an automatic gearbox, or if the vehicle is travelling on flat ground.

### Starting the system

With the vehicle travelling downhill at a speed below 19 mph (30 km/h) going forward or in reverse gear (position **D** or **R** for vehicles fitted with an automatic gearbox).

Once a sufficient gradient is detected,

the  warning light flashes on the instrument panel.

During activation of the hill descent control system is, the speed of descent can be increased with the accelerator pedal or decreased with the brake pedal.



In the event of a fault on the vehicle hill descent control, use the brake pedal to stop the vehicle.

The driver must remain particularly vigilant when driving on slippery or low-grip surfaces.

**Risk of serious injury.**



## SPEED LIMITER (1/5)



The speed limiter function helps you stay within the driving speed limit that you choose, known as the **limit speed**.



### Controls

- 1 or, depending on the vehicle, 2 or 3  
Main "On/Off" switch.

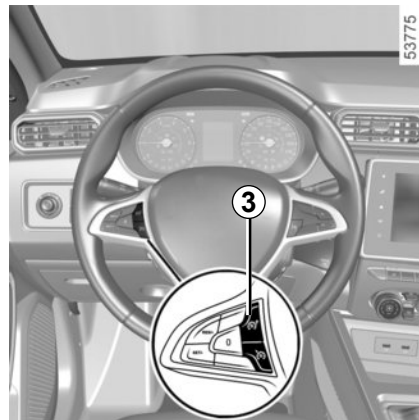

## SPEED LIMITER (2/5)

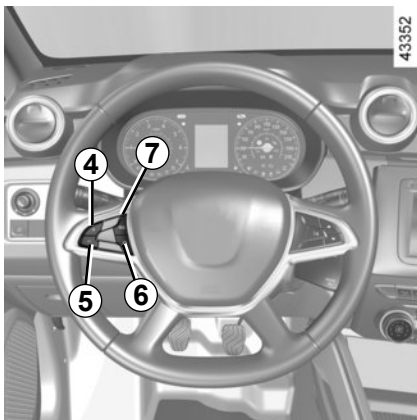

### Controls

(continued)

- 4 Speed limiter activation, memory and increase (+).
- 5 Lowers the limited speed (-).
- 6 or, depending on the vehicle, **10**  
Speed limiter function standby (with limited speed memory) (O).
- 7 Activation with recall of stored limit speed (R or, depending on the vehicle, RES).



- 8 Reminder of the stored limit speed and increase of the limit speed (RES/+).
- 9 Limit speed activation, storage and decrease switch (SET/-).

## SPEED LIMITER (3/5)

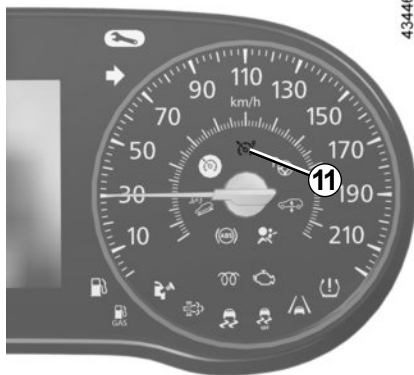

43446

### Switching on

Press switch **1** or, depending on the vehicle, switch **2**, or **3** on the  side. The warning light **11** illuminates in orange and, depending on the vehicle, the message “Speed limiter ON” or “Speed Limiter XXX” mph (km/h) appears on the instrument panel accompanied by dashes to indicate that the speed limiter function is activated and waiting to store a limit speed.

To store the current speed, press switch **4 (+)** or, depending on the vehicle, press, **9 (SET/-)**: the limited speed replaces the dashes.

The minimum stored speed is 20 mph (30 km/h).

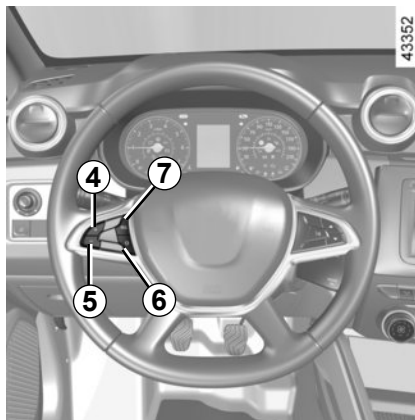

43352

### Driving

When a limited speed has been stored and this speed is not reached, driving is similar to driving a vehicle without the speed limiter function.

Once you have reached the stored speed, no effort on the accelerator pedal will allow you to exceed the programmed speed except in an emergency (refer to information on “Exceeding the limit speed”).

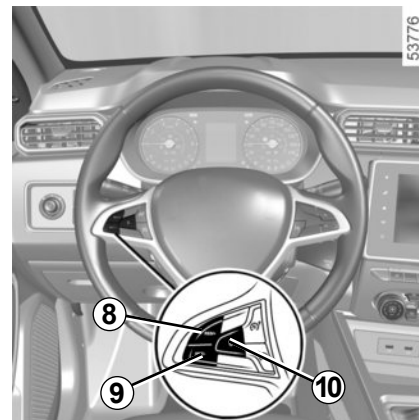

53776

### Varying the limit speed

The limit speed may be changed by repeatedly pressing:

- switch **4 (+)** or, depending on the vehicle, **8 (RES/+)** to increase the speed;
- switch **5 (-)** or, depending on the vehicle, **9 (SET/-)** to reduce the speed.



The speed limiter function is in no way linked to the braking system.

## SPEED LIMITER (4/5)

### Exceeding the limit speed

It is possible to exceed the limit speed at any time. To do this: press the accelerator pedal **firmly and fully** (beyond the resistance point).

While the speed is being exceeded, the programmed speed displayed on the instrument panel flashes.

Then, release the accelerator: the speed limiter function will return as soon as you reach a speed lower than the stored speed.

### Limited speed cannot be maintained

When driving down a steep gradient, the system is unable to maintain the limit speed: the memorised speed will flash on the instrument panel and, depending on the vehicle, an audible signal will sound at regular intervals to inform you of this situation.

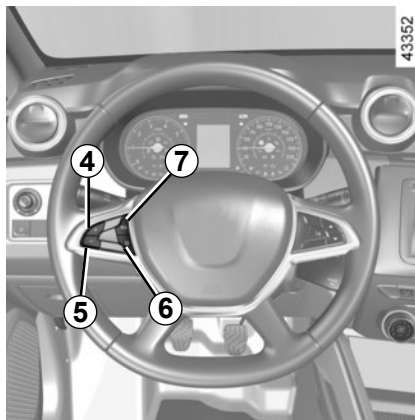

### Putting the function on standby

To suspend the speed limiter function, press switch **6** (O) or, depending on the vehicle, **10** (0). In this case, the limit speed remains stored and, depending on the vehicle, the message "Memorised XXX" mph (km/h) appears on the instrument panel accompanied by the stored speed.



### Recalling the limit speed

If a speed has been stored, it can be recalled by pressing switch **7** (R or, depending on the vehicle, RES) or, depending on the vehicle, **8** (RES/+).

When the speed limiter is set to standby, press switch **4** (+) or, depending on the vehicle **8** (RES/+) to reactivate the function without taking into account the stored speed: it is the speed at which the vehicle is moving that is taken into account.

## SPEED LIMITER (5/5)



### Switching off the function

To stop the speed limiter function, press switch **1** or, depending on the vehicle, **2** or **3**, in this case a speed will no longer be stored. The orange instrument panel warning light  goes out, confirming that the function is stopped.



The speed limiter function is in no way linked to the braking system.

## CRUISE CONTROL (1/6)

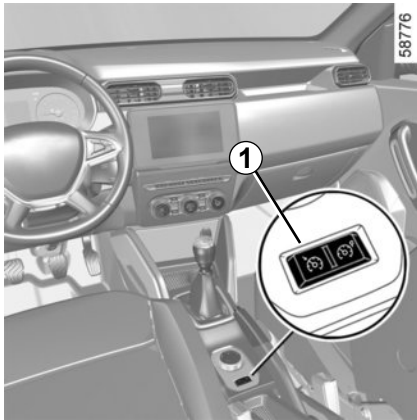

The cruise control function helps you to maintain your driving speed at a speed that you choose, called the **cruising speed**.

This cruising speed may be set at any speed above 20 mph (30 km/h).



The cruise control function is in no way linked to the braking system.

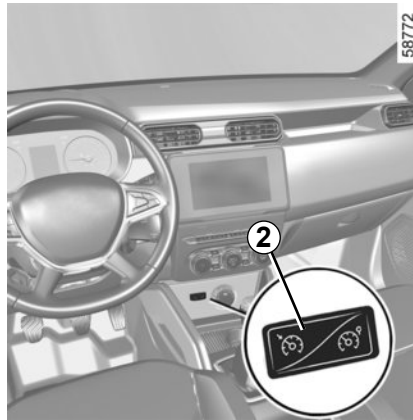

### Controls

- 1** or, depending on the vehicle, **2** or **3**  
Main "On/Off" switch.



## CRUISE CONTROL (2/6)



### Controls

(continued)

- 4 Cruising speed activation, storage and increase switch (+).
- 5 Decreasing cruising speed (-).
- 6 or, depending on the vehicle, **10**  
Switch the function to standby (with cruising speed saved) (O).
- 7 Activation with recall of stored cruising speed (R or, depending on the vehicle, RES).

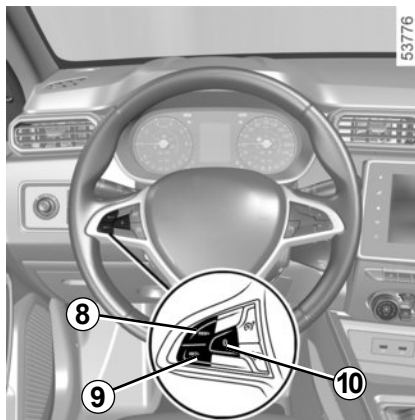

- 8 Reminder of the stored cruising speed and increase to cruising speed (RES/+).
- 9 Cruising speed activation, storage and decrease switch (SET/-).



This function is an additional driving aid.

It can under no circumstances replace the driver's responsibility to respect speed limits or to be vigilant.

The driver must always be in control of the vehicle.

Cruise control must not be used in heavy traffic, on undulating or slippery roads (black ice, aquaplaning, gravel) and during bad weather (fog, rain, side winds etc.).

**There is a risk of accidents.**

## CRUISE CONTROL (3/6)

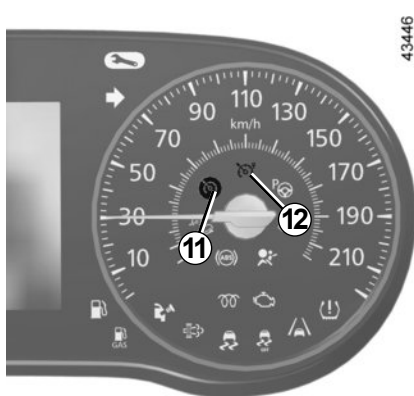

### Switching on



Press switch **1** or, depending on the vehicle, switch **2**, or **3** on the  side.

The warning light **11** illuminates in green and, depending on the vehicle, the message "Cruise control ON" appears on the instrument panel, accompanied by dashes to indicate that the cruise control function is in operation and waiting to memorise a cruising speed.



### Activating cruise control

At a steady speed above approximately 18 mph (30 km/h), press switch **4** (+) or, depending on the vehicle **9** (SET/-); the function is activated and the current speed is memorised.

The cruising speed replaces the dashes and the cruise control function is confirmed by the appearance (depending on the vehicle) of the message "Cruise Control XXX" mph (km/h) and warning light **11**  in green, as well as warning light **12** .

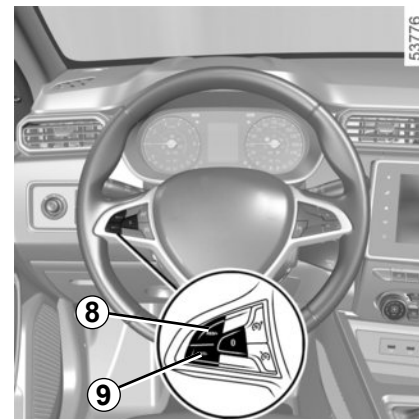



## CRUISE CONTROL (4/6)

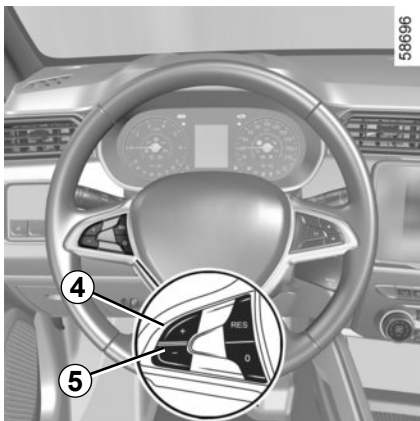

### Driving

Once a cruising speed is stored and the cruise control function is active, you may lift your foot off the accelerator pedal.



Important: you are nevertheless advised to keep your feet close to the pedals in order to react if necessary.

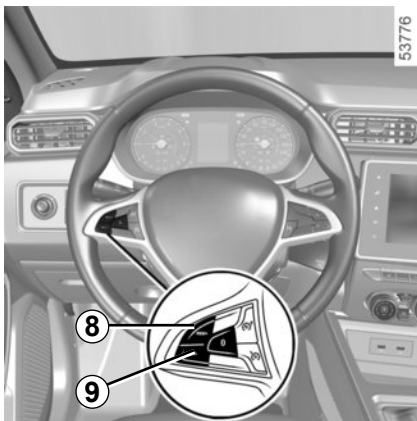

### Adjusting the cruising speed

The cruising speed may be changed by pressing the following repeatedly:

- switch **4** (+) or, depending on the vehicle, **8** (RES/+) to increase the speed,
- switch **5** (-) or, depending on the vehicle, **9** (SET/-) to reduce the speed.



The cruise control function is in no way linked to the braking system.

### Exceeding the cruising speed

The cruising speed may be exceeded at any time by depressing the accelerator pedal.

While it is being exceeded, the cruising speed flashes on the instrument panel.

Then, release the accelerator: after a few seconds, the vehicle will automatically return to its set cruising speed.

### Cruising speed cannot be maintained

When driving down a steep gradient, the system is unable to maintain the cruising speed: the stored speed will flash on the instrument panel information display to inform you of this situation.

## CRUISE CONTROL (5/6)

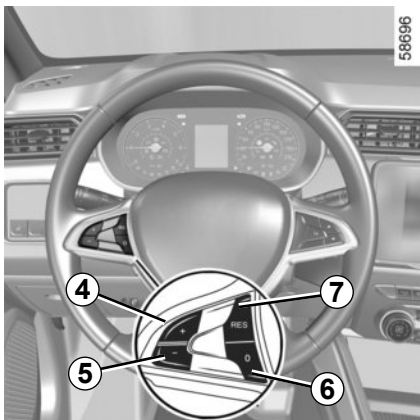

### Putting the function on standby

The function is set to standby if you:

- switch **6** (O) or, depending on the vehicle, **10** (O);
- the brake pedal;
- depress the clutch pedal or shift into neutral if the vehicle has an automatic gearbox.

In all three cases, the cruising speed remains stored and, depending on the vehicle, the message “Memorised XXX” mph (km/h) appears on the instrument panel.

Standby is confirmed when indicator light  goes out.



### Returning to the cruising speed

If a speed is stored, it can be recalled, once you are sure that the road conditions are suitable (traffic, road surface, weather conditions, etc.). Press switch **7** (R or, depending on the vehicle, RES) or, depending on the vehicle, **8** (RES/+) if the vehicle speed is above 18 mph (30 km/h).

When the stored speed is recalled, activation of the cruise control is confirmed by the illumination of the  warning light.



**NB:** if the speed previously stored is much higher than the current speed, the vehicle will accelerate more rapidly to reach this threshold.

When the cruise control is set to standby, press switch **4** (+) or, depending on the vehicle, **8** (RES/+) to reactivate the cruise control function without taking into account the stored speed: it is the speed at which the vehicle is moving that is taken into account.

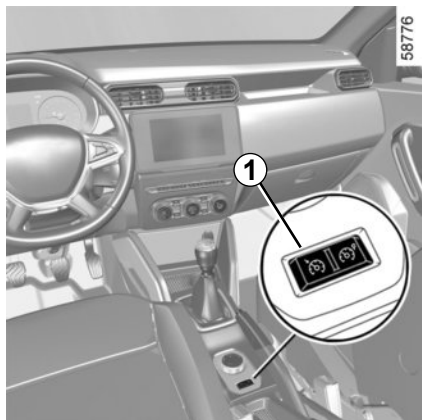
## CRUISE CONTROL (6/6)



### Switching off the function

The cruise control function is stopped if you press switch **1** or, depending on the vehicle, **2** or **3**, in this case a speed is no longer stored. The two instrument panel warning lights  and  go out to confirm that the function is deactivated.



Putting the cruise control on standby or switching it off does not cause a rapid reduction in speed: you must brake by depressing the brake pedal.

# AUTOMATIC TRANSMISSION (1/4)

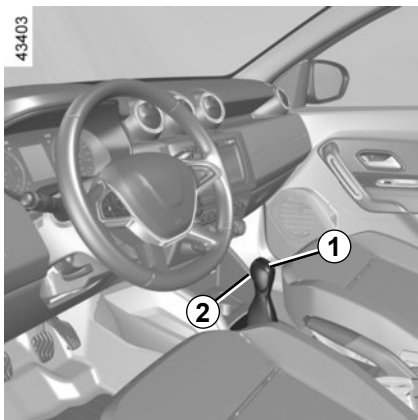

## Selector lever 1

**P:** Park

**R:** Reverse

**N:** Neutral

**D:** Automatic mode

**M:** Manual mode

**+**: upshifting gear

**-**: descending gear

**3:** displays the gear engaged in manual mode.

**Note:** Press the **2** button to go from position **D** or **N** to **R** or **P**.

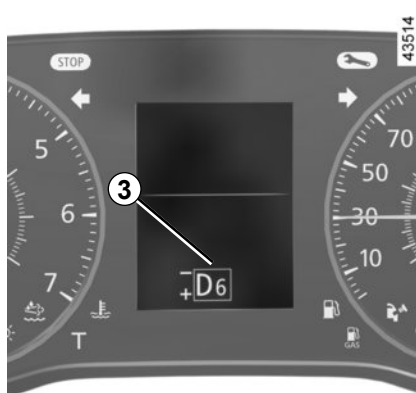

## Operation

With the selector lever **1** in **P** position, press the brake pedal then start the engine.

To move out of position **P**, you must depress the brake pedal before pressing the unlocking button **2**.

With your foot on the brake pedal (warning light  on the display goes out), move the lever out of position **P**.

The display **3** notifies the driver about the current mode and gear.

**Only engage D or R when the vehicle is stopped, with your foot on the brake, the accelerator pedal released and the engine running.**

## Driving in automatic mode

Place the lever into position **D**.

In the majority of driving conditions, you will no longer have to use your gear lever: the gears change automatically, at the right time, to a suitable engine speed because “automatic” takes the vehicle’s load, road profile and driving style into account.



For safety reasons, do not switch off the ignition before the vehicle has come to a complete standstill.

# AUTOMATIC TRANSMISSION (2/4)

## Economical driving

When driving, always leave the lever in position **D**, keeping the accelerator pedal lightly depressed to ensure automatic gear changes at a lower engine speed.

## Accelerating and overtaking

Depress the accelerator pedal firmly and fully (so that it goes beyond the kickdown point).

**This will enable you to change down to the optimum gear within the engine range.**



An impact to the underside of the vehicle while manoeuvring (e.g.: striking a post, raised kerb or other street furniture) may result in damage to the vehicle (e.g.: deformation of an axle).

To avoid any risk of accident, have your vehicle checked by an approved Dealer.

40574

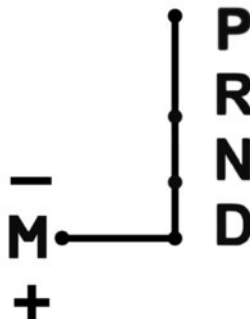

## Driving in manual mode

With the selector lever in position **D**, move the lever to the left into the **M** position.

Shifting the lever repeatedly allows you to change gears manually:

- to move down through the gears, push the lever forwards;
- to move up through the gears, push the lever backwards.

The gear selected is displayed on the instrument panel.

## Special cases

In certain driving conditions (e.g. requiring engine protection, operation of the Electronic Stability Program: ESC) the automatic system may change the gear automatically. Likewise, to prevent incorrect manoeuvres, a gear change may be refused by the automatic system: in this case the gear display flashes for a few seconds as a warning.

**In very cold weather**, the system may prevent the gears from being shifted in manual mode until the gearbox reaches the right temperature.

# AUTOMATIC TRANSMISSION (3/4)

## Special circumstances

- **If the road contour and bends in the road** do not allow you to stay in automatic mode (e.g.: in mountainous areas), it is recommended that you switch to manual mode. This will prevent the automatic gearbox from changing gears repeatedly when climbing, and permit engine braking on long descents.
- **On a slippery surface** or surface with little grip, change to manual mode **M** and select second gear before accelerating to avoid wheel-spin.

When facing uphill, to remain stopped, do not keep your foot on the accelerator.

**Risk of overheating the automatic gearbox.**

- **In cold weather** (temperatures under  $-20^{\circ}\text{C}$ ), wait a few seconds before moving the selector lever from position **P** and engaging it in **D** or **R**, then avoid strong acceleration for the first few minutes to prevent the engine stalling.

## Parking the vehicle

When the vehicle is stationary, keep your foot on the brake pedal, **apply the parking brake**, set the lever to **P** position then switch off the ignition: the gearbox is in neutral and the drive wheels are mechanically locked by the driveshaft.



Check that the indicator light **P** on the instrument panel is activated before leaving the vehicle.

**Risk of the vehicle not remaining stationary.**

## Maintenance period

Refer to the maintenance document for your vehicle or consult an Approved Dealer to check whether the automatic gearbox requires scheduled maintenance.

If it does not need to be serviced, there is no need to top up the oil.



For safety reasons, do not switch off the ignition before the vehicle has come to a complete standstill.

## AUTOMATIC TRANSMISSION (4/4)

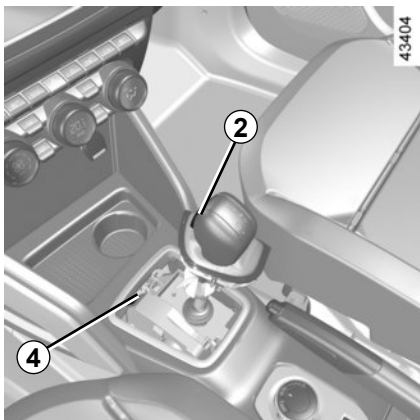

### Operating faults

**If a vehicle with an automatic gearbox breaks down**, refer to the information on “Towing” in Section 5.

**When activated**, in the event that the lever is stuck in **P**, depress the brake paddle. It is possible to free the lever manually.

To do this, unclip the base of the lever, then insert a tool (rigid rod) into the slot **4** and press simultaneously on the button **2** in order to unlock the lever. Contact an authorised dealer as soon as possible.



For safety reasons, do not switch off the ignition before the vehicle has come to a complete standstill.

## PARKING DISTANCE CONTROL (1/4)

### Operating principle

Ultrasonic sensors, fitted in the vehicle's rear bumper, measure the distance between the vehicle and an obstacle when reversing.

This measurement is indicated by beeps which become more frequent the closer you come to the obstacle, until they become a continuous beep when the vehicle is approximately 40 centimetres from the obstacle. Stop as soon as traffic conditions allow.

There is a beep when reverse gear is engaged. If the beep sounds for a long time (about 3 seconds), this signals an operating fault.

The function does not take into account towing or carrying systems that are not recognised by the system.

**Note:** in the event of a change in trajectory during a manoeuvre, the risk of collision with an obstacles may be signalled late.



43383

### Location of the ultrasonic sensors

Ensure that the ultrasonic sensors are not obscured (by dirt, mud, snow, a badly fitted/attached number plate), impacted, modified (including paintwork) or obstructed by any accessory fitted to the rear and/or, depending on the vehicle, to the front or sides of your vehicle.



This function is an additional driving aid.

Under no circumstances should it replace the driver's care or responsibility whilst reversing.

The driver should always look out for sudden hazards during driving: always ensure that there are no moving obstacles (such as a child, animal, pram, bicycle, etc.) or small, narrow objects such as stones or posts in your path when manoeuvring.



## PARKING DISTANCE CONTROL (2/4)

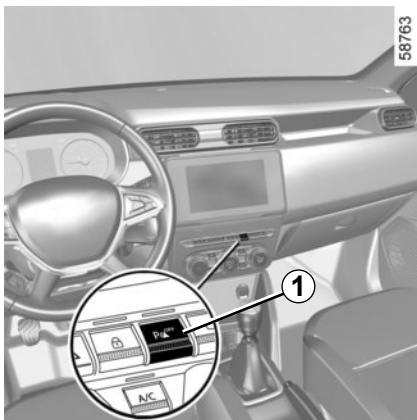

An impact to the underside of the vehicle while manoeuvring (e.g.: striking a post, raised kerb or other street furniture) may result in damage to the vehicle (e.g.: deformation of an axle).

To avoid any risk of accident, have your vehicle checked by an approved dealer.

### Deactivating the system

You can deactivate the system by pressing switch **1**.

The warning light above the **1** switch remains permanently illuminated.

The deactivated system can be reactivated by pressing the switch again.

You must disable the function if:

- if towing, carrying or trailer equipment that is unrecognised by the system is present in front of the ultrasonic sensors;
- in the event of damage to the ultrasonic sensors.

### Operating faults

When the system detects an operating fault, there will be a three-second continuous beep as a warning. Consult an approved dealer.

## PARKING DISTANCE CONTROL (3/4)

### **System servicing/repairs**

- In the event of an impact, the alignment of the sensors may be altered and their operation may consequently be affected. Deactivate the function and consult an authorised dealer.
- Any work in the area where the sensors are located (repairs, replacements, etc.) must be carried out by a qualified professional.

Only an authorised dealer is qualified to service the system.

### **System disturbance**

Some conditions can disrupt or damage the operation of the system, for example:

- poor weather conditions (rain, snow, hail, black ice, etc.);
- in the event of exposure to strong electromagnetic waves (under high-voltage lines, etc.);
- some types of noise (motorcycle, lorry, pneumatic drill etc.);
- fitting a non-compatible towing ball or hook;
- ...

### **Risk of false alarms or absence of warnings**

In the event of the system behaving abnormally, deactivate it and consult an authorised dealer.

## PARKING DISTANCE CONTROL (4/4)

### **Limitation of the system operation**

- The area around the sensors must be kept clean and free of any modifications in order to ensure the proper operation of the system.
- Small objects moving close to the vehicle (motorcycles, bicycles, pedestrians, etc.) may not be recognised by the system.
- The system may not detect objects that are too close to the vehicle.
- The system may not provide a warning when the other vehicles or objects are travelling at a significantly different speed.
- When there is a change in trajectory during a manoeuvre, the system may be slow in reporting obstacles.
- When the vehicle is towing a trailer, the rear Park Assist system must be deactivated.

### **Deactivating the function**

You must disable the function if:

- the area around the sensors has been damaged;
- the vehicle is equipped with a towing device that is not recognised by the system (electrical adapter, ball, hook, etc.).

## REVERSING CAMERA (1/3)

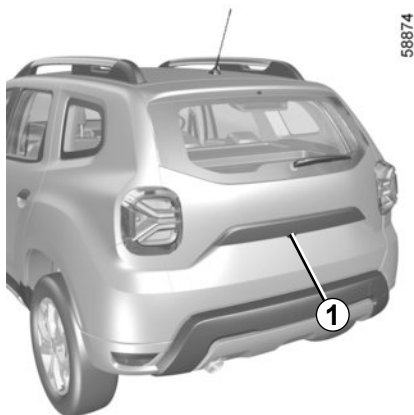

### Operation

When using reverse gear, the camera **1** located near the tailgate sends a view of the area behind the vehicle to the multimedia display **2** together with a static guide line.

This system is used with the aid of a fixed distance gauge. When the red zone is reached, use the bumper image to stop accurately.

**Note:** make sure that the reversing camera is not obscured (by dirt, mud, snow, condensation, etc.).

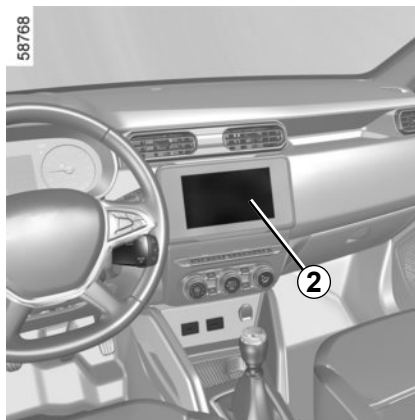

This function is an additional aid. It cannot, therefore, under any circumstances replace the vigilance or the responsibility of the driver.

The driver should always pay attention to sudden incidents during driving: always ensure that there are no moving obstacles (such as a child, animal, pram, bicycle, etc.) or small, narrow objects such as stones or posts in your path when manoeuvring.

### Settings

While the engine is running, from the multimedia screen **2** you can add or remove the guides and adjust the camera image settings (brightness, contrast etc.). Please refer to the multimedia instructions for further information.

### Operating faults

When reverse gear is engaged, if the system detects an operating fault, a black screen is displayed temporarily on the multimedia screen **2**.

This may be caused by a fault affecting the camera or screen (clearness, fixed image, delayed communication etc.).

If the temporary display of the black screen persists, please consult an approved dealer.

## REVERSING CAMERA (2/3)

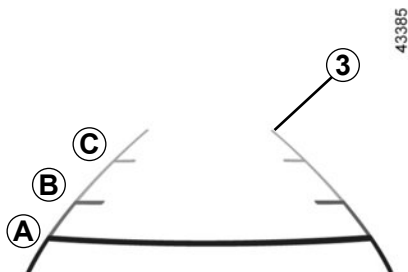

### Static guide line 3:

The static guide line **3** has coloured markers **A**, **B** and **C** showing the distance behind the vehicle:

- **A** (red) approximately 30 centimetres from the vehicle;
- **B** (yellow) approximately 70 centimetres from the vehicle;
- **C** (green) approximately 150 centimetres from the vehicle.

This gauge remains fixed and indicates the vehicle trajectory if the wheels are in line with the vehicle.

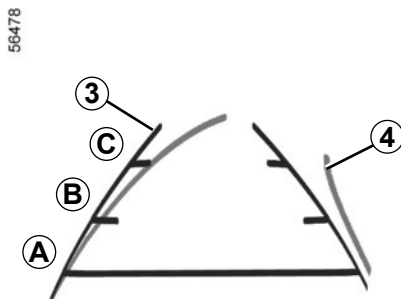

### 4 moving guide line

(depending on the vehicle)

This is shown in blue on the multimedia screen **2**. It indicates the vehicle trajectory according to the position of the steering wheel.

The screen shows a reverse image.

The frames are a representation projected onto flat ground; this information must not be taken into account when superimposed on a vertical object or an object on the ground.

Objects which appear on the edge of the screen may be deformed.

In very bright light (snow, vehicle in sunshine etc.), the camera vision may be adversely affected.

## REVERSING CAMERA (3/3)

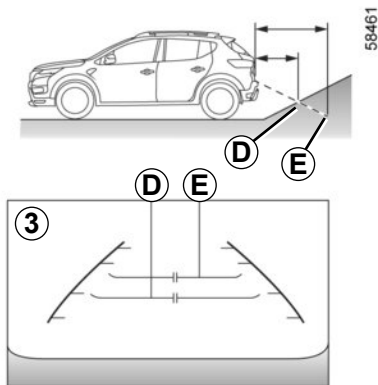

### Difference between the estimated distance and actual distance

#### Reversing towards a steep uphill slope

The fixed guidelines **3** show the distances as closer than they actually are.

The objects shown on the screen are actually further away on the slope.

For example, if the screen displays an object at **D**, the actual distance of the object is at **E**.

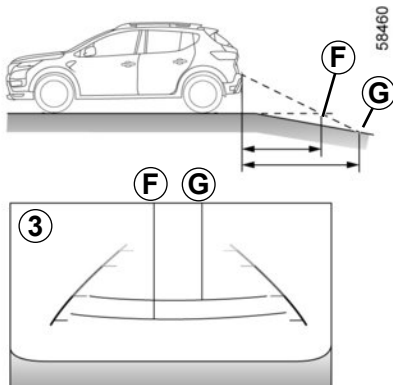

### Reversing towards a steep downhill slope

The fixed guidelines **3** show the distances as further than they actually are.

Therefore, the objects shown on the screen are actually closer on the slope.

For example, if the screen displays an object at **G**, the actual distance of the object is at **F**.

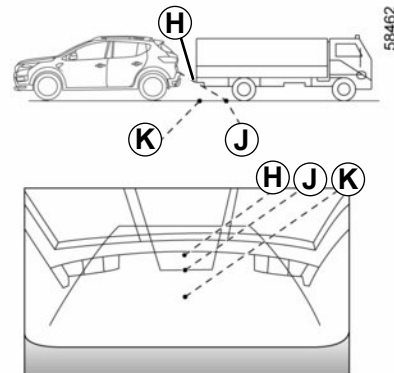

### Reversing towards a protruding object

Position **H** seems further than position **J** on the screen. However, position **H** is at the same distance as position **K**.

The trajectory indicated by the fixed and mobile guidelines do not take into account the height of the object. So there is a risk that the vehicle may collide with the object when reversing towards position **K**.

## BLIND SPOT WARNING (1/4)

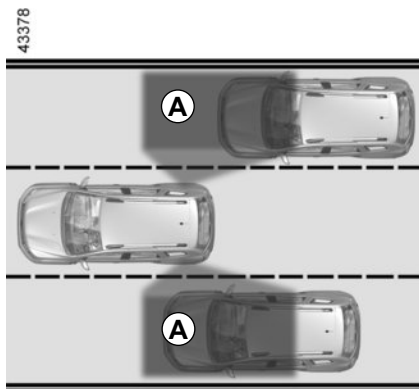

This system alerts the driver to other vehicles in the detection zone **A**.

The system is activated when the vehicle's speed is between approximately 30 km/h (19 mph) and 140 km/h (87 mph).

This function uses sensors **1** installed in the front and rear bumper of both sides.

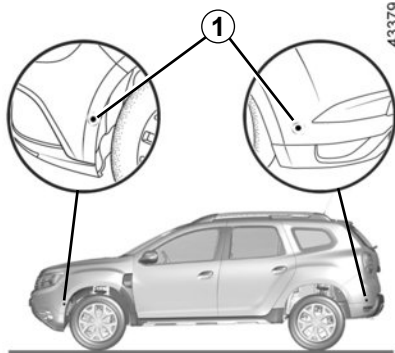

### Special feature

Make sure that the sensors are not obscured (by dirt, mud, snow, etc.). If a sensor is obscured, the message "Blind spotclean sensor" will appear on the instrument panel. Clean the sensors.



This function is an additional aid which indicates other vehicles in the blind spot area.

It can never in any case be a substitute for care nor for the driver's responsibility while in charge of his vehicle.

The driver should always be ready for sudden incidents while driving: always ensure that there are no small, narrow moving obstacles (such as a child, animal, pushchair, bicycle, stone, post, etc.) in the blind spot when manoeuvring.

## BLIND SPOT WARNING (2/4)

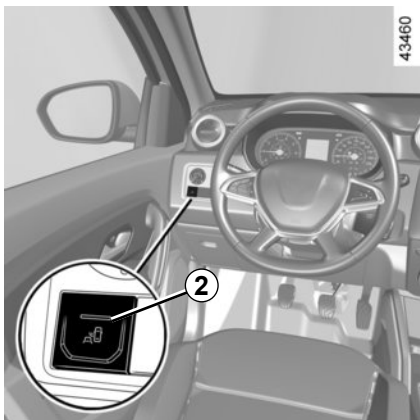

### Activation/deactivation

If you press switch **2**, the system is activated and the message “Blind spot alert on” appears on the instrument panel.

Press again and the system is disabled and the message “Trailer: blind spot alert off” appears.

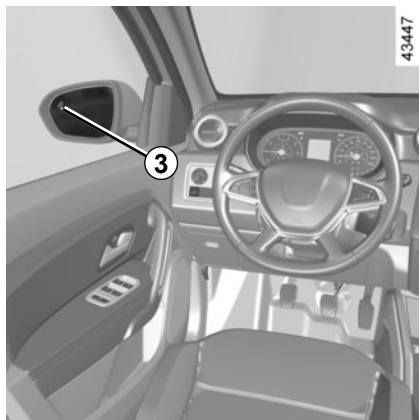

### Operation

This function gives a warning:

- when the vehicle speed is between approximately 19 mph (30 km/h) and 87 mph (140 km/h);
- when another vehicle is in the blind spot area and travelling in the same direction as your vehicle.

If your vehicle is overtaking another vehicle, the indicator **3** will be activated only if that vehicle remains in the blind spot for more than one second.

When the engine is started, the system remembers its position when the ignition was last switched off.



## BLIND SPOT WARNING (3/4)

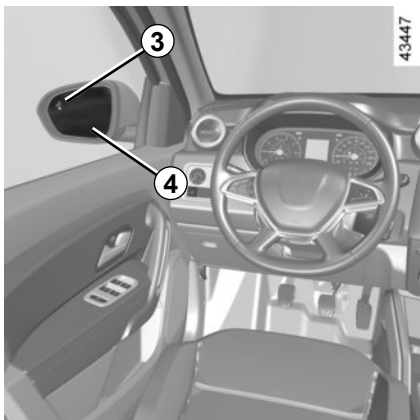

### Indicator 3

An indicator light **3** is situated on both rear view mirrors **4**.

**Note:** clean the rear view mirrors **4** regularly so that the indicators **3** can be seen.

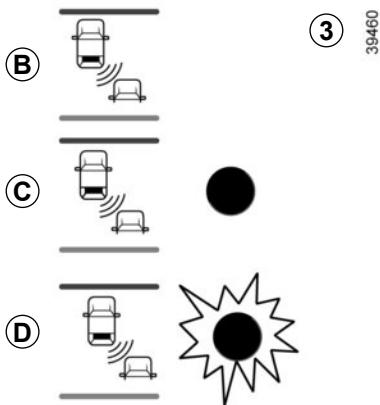

### Display B

The function is activated and has not detected any vehicles.

### Display C

First warning: the indicator **3** means that a vehicle has been detected in the blind spot.

### Display D

When the direction indicator is activated, the indicator light **3** flashes when a vehicle is detected in the blind spot on the side towards which you are about to steer. If you cancel the direction indicator, the function will return to the initial warning (display **C**).

The system's detection range operates according to a standard lane width. If you are driving in narrow traffic lanes, it may detect vehicles in other lanes.

## BLIND SPOT WARNING (4/4)

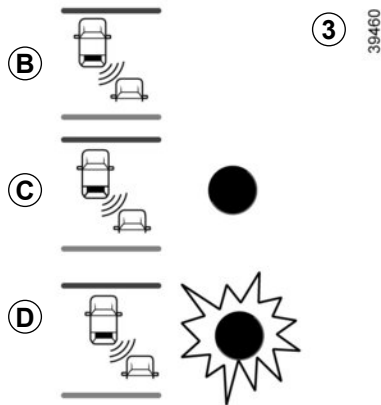

### Conditions for non-function

- If the object is not moving;
- if traffic is heavy;
- the road is winding;
- if front and rear sensors both detect an object at the same time (e.g. when passing an articulated lorry).
- ...

### Operating faults

If the system detects a fault, the message “Check blind spot alert” is displayed on the instrument panel. Call an approved Dealer.

**Note:** when the engine is started, the indicator light 3, display B, flashes three times. It is normal.

If a trailer is attached to the vehicle, the system must be disabled with the 2 switch.



- The system’s detection range operates according to a standard lane width. If you are driving in wide traffic lanes, the system might not be able to detect a vehicle in the blind spot.
- The system might be disrupted momentarily if it is exposed to strong electromagnetic waves (as beneath high-tension power lines) or to very poor weather conditions (heavy rain, snow etc.). Remain aware of driving conditions.

**There is a risk of accidents.**

Because sensors have been installed in the bumpers, it is advisable for any work (repairs, replacements, touching up of paintwork etc.) to be carried out by a qualified professional.

## MULTI-VIEW CAMERA (1/6)

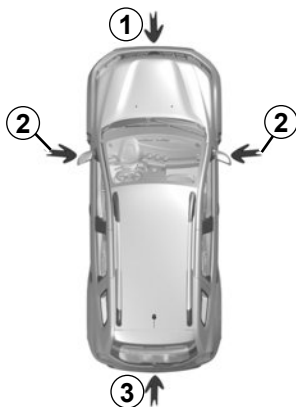

If fitted on the vehicle, the four cameras **1**, **2** and **3** located in the front bumper, door mirrors and tailgate help you with difficult manoeuvres.

The cameras transmit four separate views to the **4** screen, which makes it possible to view the vehicle environment.

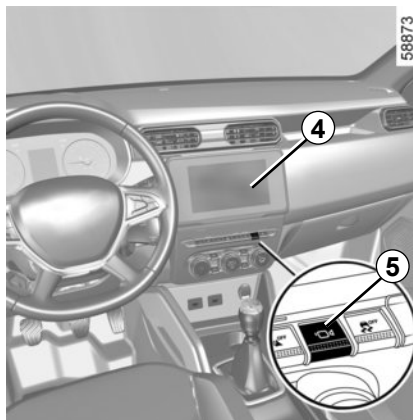

**Note:** Make sure that the cameras are not obscured (by dirt, mud, snow etc.).

### Activating the system

With the ignition on, the system may be activated:

- in automatic mode, on changing into reverse gear: the system is activated and the camera located on the tailgate provides a view of the surroundings behind the vehicle on the **4** screen;
- in manual mode, by pressing switch **5**: the system is activated and the camera located in the front bumper provides a view of the surroundings in front of the vehicle on the **4** screen.

**Note:** depending on the vehicle, certain settings can be adjusted from the **4** touchscreen. Refer to the multimedia instructions.



This function is an additional aid. It cannot, therefore, under any circumstances replace the vigilance or the responsibility of the driver.

The driver should always be ready for sudden incidents while driving: always ensure that there are no small, narrow moving obstacles (such as a child, animal, pushchair, bicycle, stone, post etc.) in the blind spot when manoeuvring.

## MULTI-VIEW CAMERA (2/6)

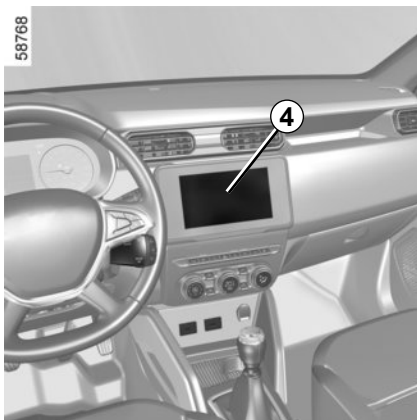

### Automatic mode

Automatic mode is activated when reverse gear is engaged and the **4** screen shows the view from the rear view camera. When there is a quick change from reverse gear to a forward gear, the **4** screen shows the image from the front camera.

Automatic mode is disabled:

- by selecting another camera view from the menu on the **4** screen;
- automatically as soon as you reach about 12 mph (20 km/h);
- by deactivating the system, refer to the information on “Multi-view camera - Deactivating the system”.

### Manual mode

To activate it, select the desired camera view from the menu on the **4** screen.

A message appears on the **4** screen for approximately 5 seconds to confirm the activation of manual mode.

Manual mode is disabled:

- automatically as soon as you reach about 12 mph (20 km/h);
- by deactivating the system, refer to the information on “Multi-view camera - Deactivating the system”.

## MULTI-VIEW CAMERA (3/6)



58874

### Reversing camera 3

If the rear camera is activated automatically or manually, the view from the camera is displayed on the 4 screen.

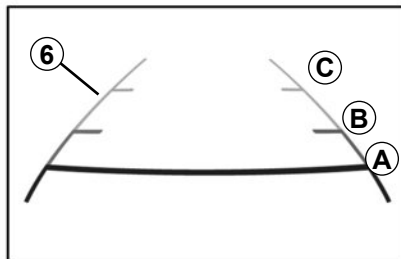

43555

### Fixed clearance gauge 6

The fixed clearance gauge comprises coloured markers **A**, **B** and **C** indicating the distance behind the vehicle:

- **A** (red) approximately 30 centimetres from the vehicle;
- **B** (yellow) approximately 70 centimetres from the vehicle;
- **C** (green) approximately 150 centimetres from the vehicle.

The image displayed on the multimedia screen may seem faster than reality.

56478

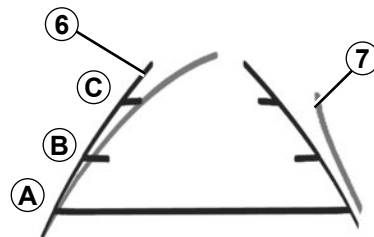

### 7 moving guide line

(depending on the vehicle)

This is shown in blue on the multimedia screen 4. It indicates the vehicle trajectory according to the position of the steering wheel.

## MULTI-VIEW CAMERA (4/6)

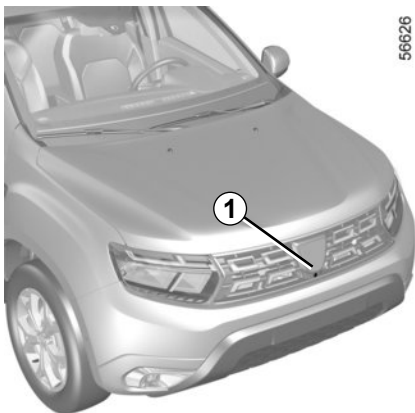

### Front camera 1

If the front camera is activated automatically or manually, the view from the camera is displayed on the **4** screen.

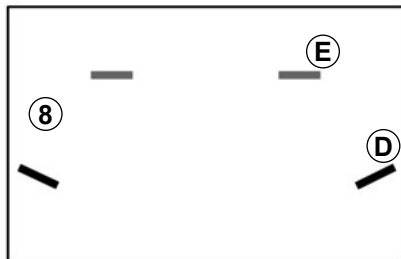

### Fixed clearance gauge 8

The fixed clearance gauge comprises coloured markers **D** and **E** indicating the distance behind the vehicle:

- **D** (yellow) approximately 70 centimetres from the vehicle;
- **E** (green) approximately 150 centimetres from the vehicle.



An area of 24 in (60 cm) in front of the vehicle is not recognised by the system and does not appear on the screen. Remember this area.

**Risk of damage to the vehicle.**

## MULTI-VIEW CAMERA (5/6)



### Side cameras 2

the **2** cameras, installed in the door mirrors, create the side views on the **4** screen.

To activate the desired camera view, select it on the **4** screen: See the multimedia equipment instructions for further information.

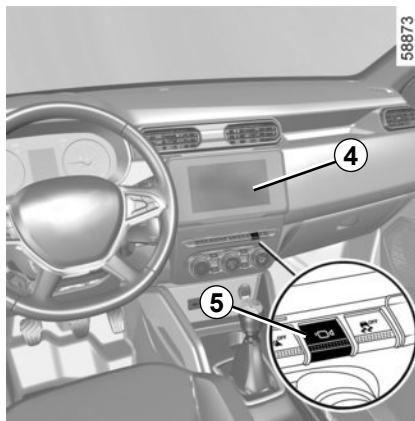

### Deactivating the system

The system may be disabled:

- when the vehicle is travelling faster than about 12 mph (20 km/h);
- depending on the vehicle, when the gear lever is moved to position **P** or **N** in automatic mode;
- by pressing switch **5**.

## MULTI-VIEW CAMERA (6/6)

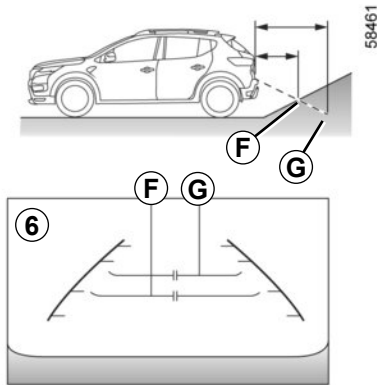

### Difference between the estimated distance and actual distance

#### Driving or reversing towards a steep uphill slope

The fixed guidelines **6** show the distances as closer than they actually are.

The objects shown on the screen are actually further away on the slope.

For example, if the screen displays an object at **F**, the actual distance of the object is at **G**.

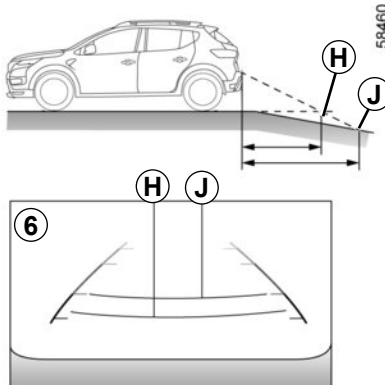

### Driving or reversing towards a steep downhill slope

The fixed guidelines **6** show the distances as further than they actually are.

Therefore, the objects shown on the screen are actually closer on the slope.

For example, if the screen displays an object at **J**, the actual distance of the object is at **H**.

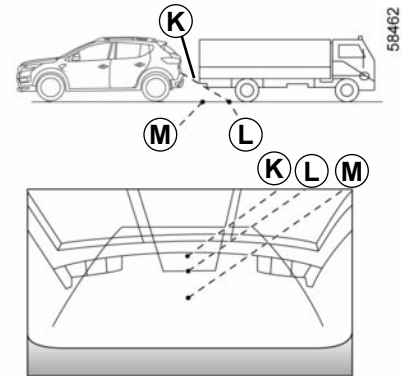

### Driving or reversing towards a protruding object

Position **K** seems further than position **L** on the screen. However, position **K** is at the same distance as position **M**.

The trajectory indicated by the fixed and mobile guidelines do not take into account the height of the object. So there is a risk that the vehicle may collide with the object when reversing towards position **M**.



## EMERGENCY CALL (1/3)

If the vehicle is equipped, the emergency call function can be used to call the emergency services (without charge) automatically or manually in the event of an accident or illness, reducing the time it takes for the emergency services to arrive.

**Note:** the emergency call operates:

- in countries covered by the associated telematics emergency services and infrastructure compatible with the system;
- depending on the network coverage in the geographical region where the vehicle is being driven.

If you use the emergency call function to report an accident which you have witnessed, this implies stopping where traffic conditions allow to allow the emergency services to locate your vehicle and therefore the location of the reported accident.

In all cases, comply with local legislation.

Use the emergency call only in the event of an emergency you are involved in, if you witness an accident or if you feel ill.

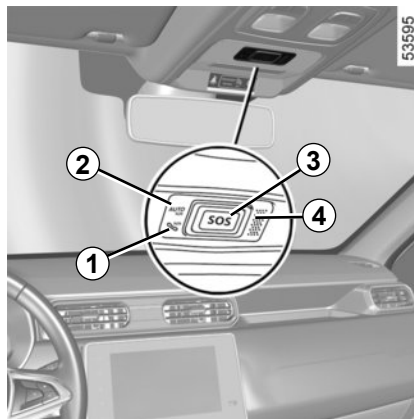

- 1 System operation warning light:
  - green: operational (network available);
  - off: non-operational (network unavailable);
  - red: operating fault;
  - green flashing: call in progress.
- 2 Automatic mode warning light.
- 3 SOS button.
- 4 Microphone.
- 5 or 6 (depending on the vehicle) Speaker.

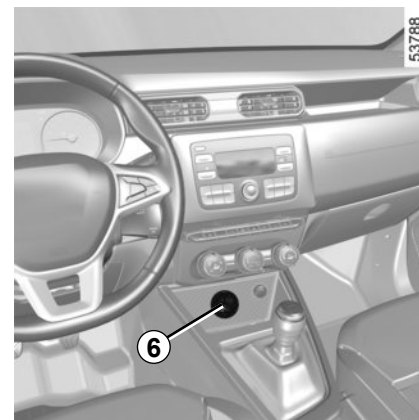
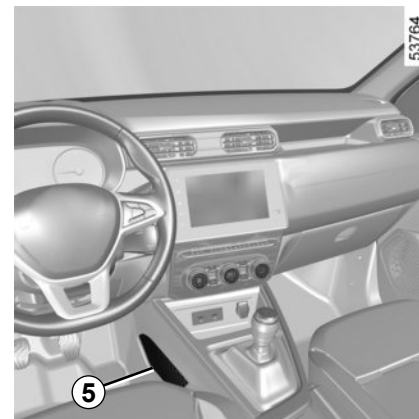

## EMERGENCY CALL (2/3)

A call is always made as follows:

- the call is set up with the emergency services;
- send data related to the incident (vehicle identification plate, local time of the call, last positions, direction of the vehicle);
- voice communication with the emergency services;
- if necessary, emergency assistance is called.

Emergency call has two modes:

- automatic mode;
- Manual mode.

### Automatic mode

If the automatic mode **2** warning light appears in green this confirms that the automatic system is activated.

The emergency call starts automatically in the event of an accident that has required the activation of the protective equipment (seat belt pretensioners, airbag etc.).

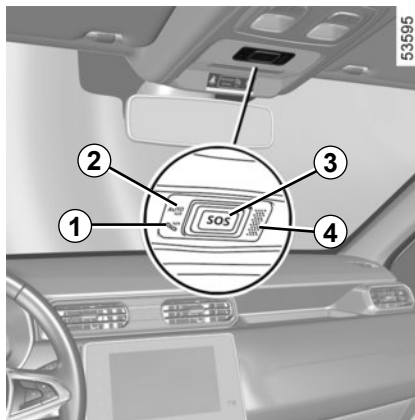

### Manual mode

The emergency call is carried out by:

- pressing and holding the **3** button for at least 3 seconds;
- or
- pressing the **3** button five times within ten seconds.

In the event of unintended operation, it is possible to cancel the call by pressing the **3** button for around two seconds, before the call is connected to the call centre.

Once a call is established, only the call centre can end the call.

### Test mode

(depending on local laws)

Test mode is **reserved** for Approved Dealers to check that the emergency call feature is working properly.

To activate test mode:

- briefly press the **3** button three times;
- wait approximately 15 seconds;
- briefly press the **3** button three times.

Exit from test mode is automatic.



In the event of an accident, if the location and traffic conditions permit, stay close to the vehicle in order to be able to answer the call centre quickly if necessary.

## EMERGENCY CALL (3/3)



### Operating faults

In some cases, the emergency call may not work (e.g. low battery).

When the system detects an operating fault, the **1** warning light turns red for over 30 minutes; consult an Approved Dealer as soon as possible.

The system operates with a dedicated battery. The battery service life is approximately 4 years (the **1** warning light lights up in red to inform you).

Consult an approved dealer



To guarantee your safety and the proper operation of the system, any operation carried out on the battery (removal, disconnection, etc.) must be carried out by a qualified specialist.

### Risk of serious burns or electric shocks.

You must respect the replacement intervals (without exceeding them) as stated in the maintenance document.

The battery is a specific type. Please ensure it is replaced with the same type.

Call an approved Dealer.

Without the emergency call feature, the system is not trackable and will not be under constant surveillance. Data is automatically and constantly erased, and the system stores only the last three positions of the vehicle.

Data is only sent in the event of an emergency call. Data sent to the call centre is treated according to the personal data protection laws applicable in the country where you are located. The system stores activity history data for 13 hours only.

The vehicle owner has the right of access to their data. They can request that the data be corrected, deleted or locked.



# Section 3: Your comfort

Air vents, air outlets . . . . .	3.2
Heating, Ventilation, Air conditioning . . . . .	3.5
Automatic climate control . . . . .	3.9
Air conditioning: information and advice on use . . . . .	3.13
Electric windows . . . . .	3.15
Interior lighting . . . . .	3.18
Sun visor, Grab handle . . . . .	3.20
Ashtrays, Cigarette lighter, Accessories socket . . . . .	3.21
Rear headrests . . . . .	3.23
Passenger compartment storage space and fittings . . . . .	3.25
Rear bench seat . . . . .	3.30
Luggage compartment . . . . .	3.33
Transporting objects in the luggage compartment . . . . .	3.34
Transporting objects: towing, towing equipment . . . . .	3.36
Rear parcel shelf . . . . .	3.37
Roof bars, spoiler . . . . .	3.38
Multimedia equipment . . . . .	3.42

## AIR VENTS, air outlets (1/3)

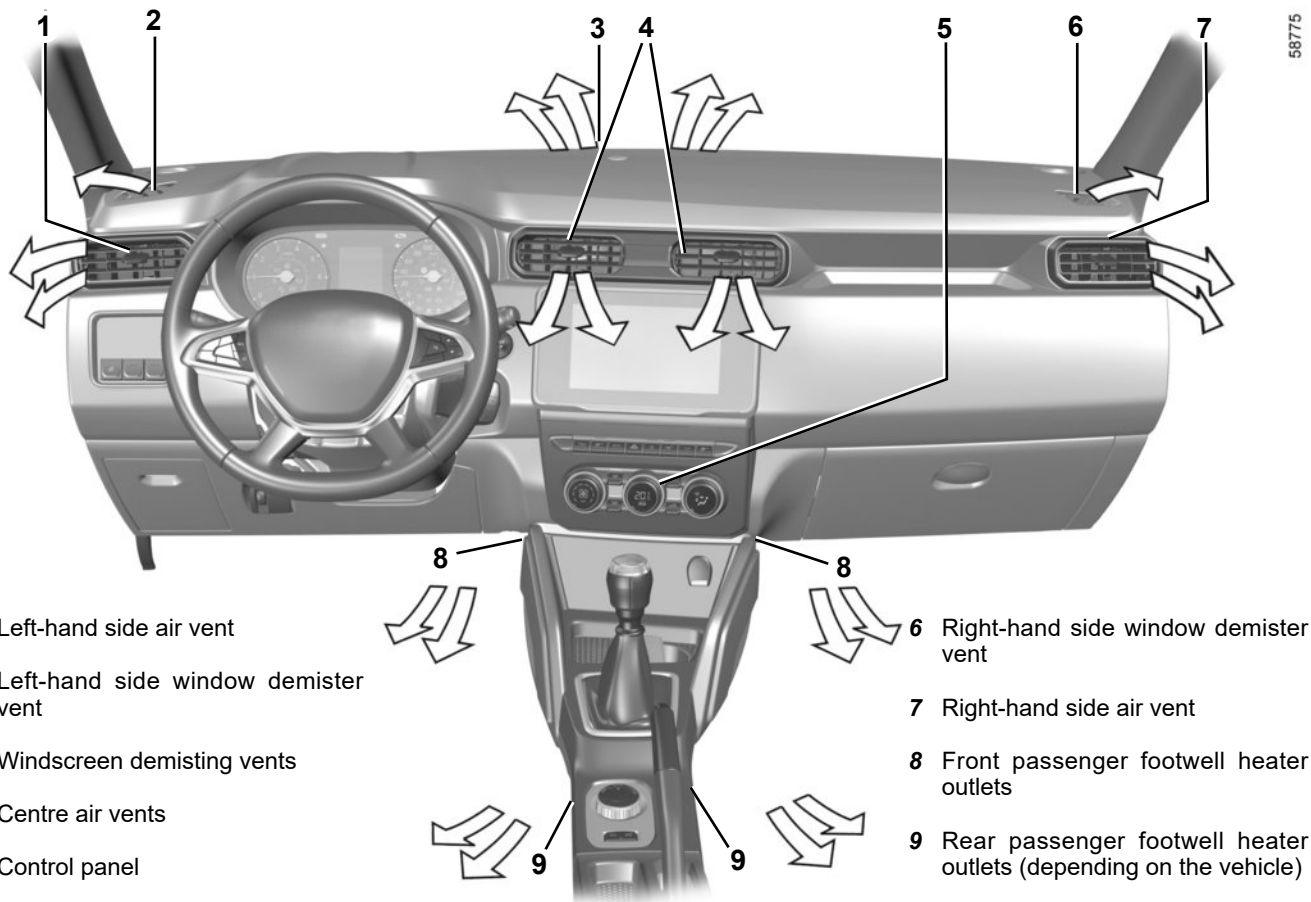

58775

## AIR VENTS, air outlets (2/3)

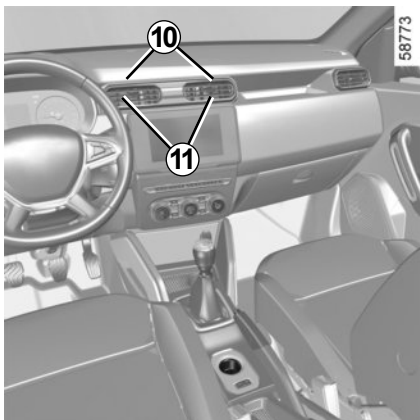

### Centre and side air vents

(depending on the vehicle)

#### Air flow

##### Air vents 10

To open: move the cursor **11** to the left.

To close: move the cursor **11** to the right, as far as it will go.

##### Air vents 13

To open press on the air vent (point **12**) until it is open as far as required.

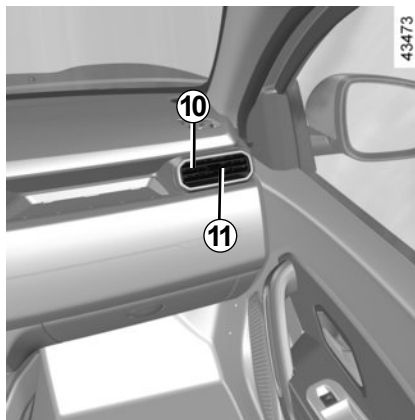

#### Direction

##### Air vents 10

Move the cursor **11** to the desired position.

##### Air vents 13

Swivel the air vent **13**.

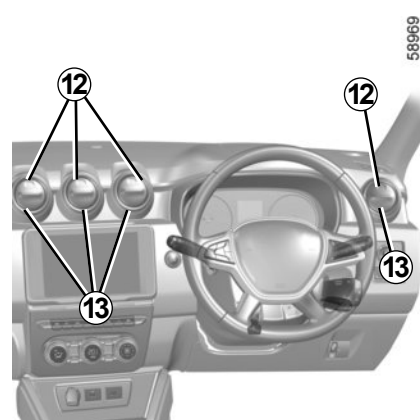

To remove bad odours from your vehicles, only use the systems designed for this purpose. Consult an approved Dealer.

## AIR VENTS, air outlets (3/3)



### Rear seats

(depending on vehicle)

Passenger footwell heater outlets **14**.



Do not add anything to the vehicle's ventilation circuit (for example, to remove bad odours).

**There is a risk of damage or of fire.**

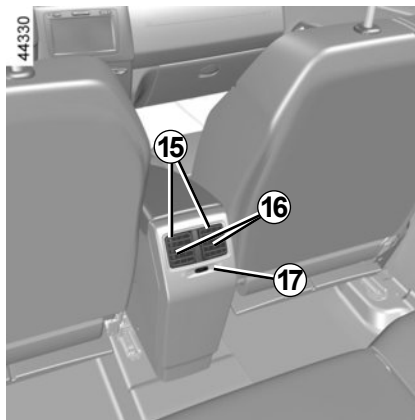

### Air vents **15**

#### Right/left direction

Move cursor **16**.

#### Air flow

Turn control knob **17**:

to : maximum air flow;

to : closed.



# HEATING, VENTILATION, AIR CONDITIONING (1/4)

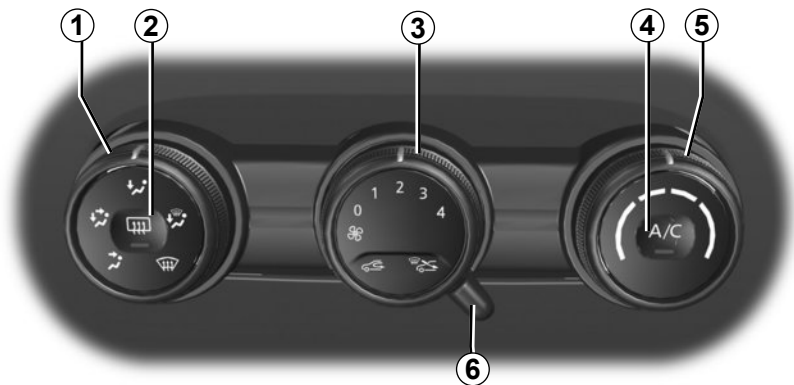

53594

## Controls

The controls will depend on the vehicle equipment level.

- 1 Distribution of air.
- 2 De-icing/demisting of the rear screen and, depending on the vehicle, the rear view mirrors and windscreen.
- 3 Adjusting the ventilation fan speed.
- 4 Switching air conditioning on or off.
- 5 Air temperature adjuster.
- 6 Switching passenger compartment isolation mode/air recirculation mode on

**Information and advice on use:** refer to information on "Air conditioning: information and advice on use".

## Adjusting the air temperature

Turn control **5** to obtain the desired temperature. The further towards the red the slide is, the higher the temperature will be.

## Adjusting the ventilation fan speed.

Move control **3** from 0 to 4 or to  (depending on the vehicle). The further the control is positioned to the right, the greater the amount of air blown into the passenger compartment. If you want to shut off the flow of air completely and stop the system, set control **3** to 0.

The system is deactivated: the ventilation speed for the passenger compartment air is zero (vehicle stationary), you can however still feel a slight flow of air when the vehicle is moving.

Leaving this control in position 0 for prolonged periods can lead to condensation forming on the side windows and windscreen and problems due to the use of non-renewed air in the passenger compartment.

## HEATING, VENTILATION, AIR CONDITIONING (2/4)

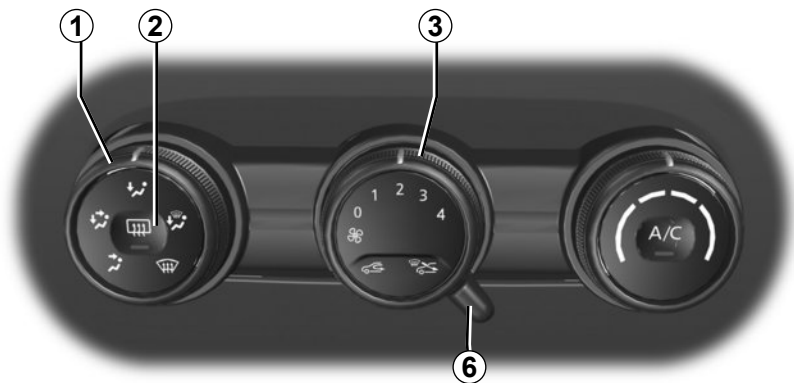

### Switching passenger compartment isolation mode/ air recirculation mode on.

Bring lever **6** to position .

Under these conditions, air is taken from the passenger compartment and is recirculated, with no air being taken from outside the vehicle.

### Air recirculation is used to:

- to isolate the passenger compartment from the external atmosphere (e.g. driving in polluted areas, etc.);
- to bring the passenger compartment to the desired temperature as quickly as possible.

Prolonged use of air recirculation can lead to condensation forming on the side windows and windscreen, and discomfort due to the use of non-renewed air in the passenger compartment.

You are therefore advised to return to normal mode (external air) as soon as the air recirculation function is no longer required, by turning control **6** to the right.

### Rapid demisting

Turn controls **1**, **3** and **6** to:

- demisting 
- maximum fan speed;
- external air.

Using the air conditioning increases the speed of demisting.



### Heated rear screen

With the engine running, press the control **2**. The operating tell-tale comes on.

Depending on the vehicle, this function de-ices/demists the rear screen and the exterior rearview mirrors.

Depending on the vehicle, the function is stopped:

- after a period of time set by the system, the warning light goes out automatically;
- by pressing button **2** again, the warning light goes out.

# HEATING, VENTILATION, AIR CONDITIONING (3/4)

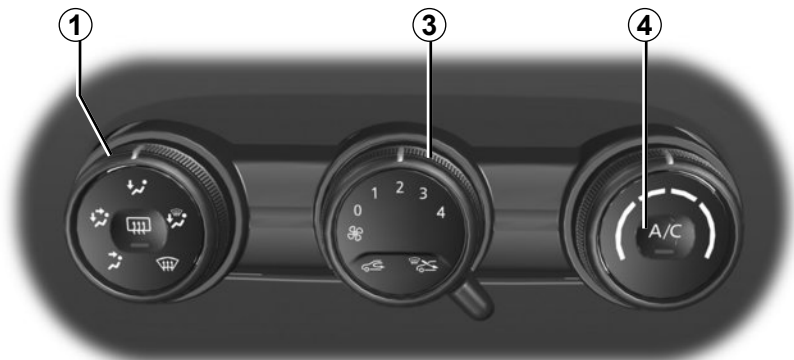

## Distribution of air in the passenger compartment

Turn control **1** to choose the distribution option.



All the air flow is directed to the dashboard vents.



The air flow is directed towards the dashboard vents and the footwells.



The air flow is mainly distributed between the front and rear footwells and the dashboard vents. Close the dashboard vents to direct all the air to the foot wells.



The air flow is distributed between all the air vents, the front side window demisting air vents, the windscreen demisting vents and the footwells.



All the air is then directed to the windscreen and front side window demisting vents.

## Switching air conditioning on or off

The air conditioning is switched on (indicator light lit) or off (indicator light off) using control **4**.

Activation is not possible if control **3** is set to 0.

## The air conditioning system is used for:

- lower the temperature inside the passenger compartment;
- eliminate condensation more quickly.

The air conditioning does not operate when the exterior temperature is low.

Fuel consumption increases when the air conditioning is being used (switch it off when it is not required).

## HEATING, VENTILATION, AIR CONDITIONING (4/4)



### Heated windscreen

**With the engine running**, press switch **7** (the built-in warning light comes on).

This function de-ices/demists the windscreen (on equipped vehicles).

**To exit the function**, press switch **7** again.

Fuel consumption increases when the air conditioning is being used (switch it off when it is not required).

# AUTOMATIC AIR-CONDITIONING (1/4)

43355

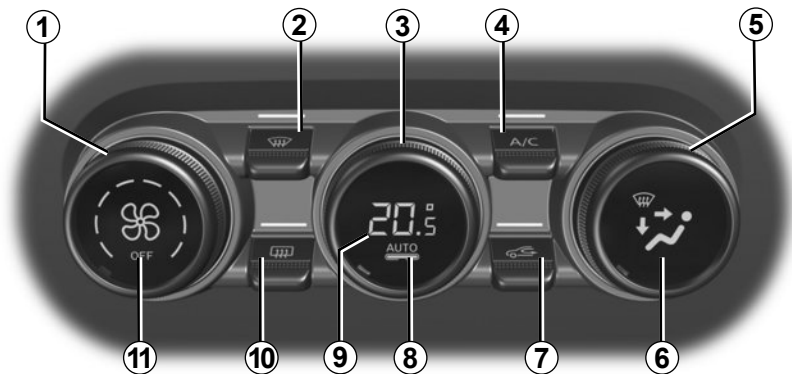

## The controls

(depending on vehicle)

- 1 Adjusting the ventilation fan speed.
- 2 “Clear View” function.
- 3 Adjusting the air temperature.
- 4 Switching air conditioning on or off.
- 5 Passenger compartment air distribution adjustment.
- 6 Air distribution mode display.
- 7 Switching passenger compartment isolation mode/air recirculation mode on

- 8 Automatic mode.
- 9 Temperature display.
- 10 De-icing/demisting of the rear screen and, depending on the vehicle, the rear view mirrors.
- 11 Ventilation speed display.

## Automatic mode

The automatic climate control system guarantees comfort in the passenger compartment and good visibility (except in the event of extreme conditions), while optimising consumption. The system controls the ventilation speed, air distribution, air recirculation, and starting and stopping the air conditioning and air temperature.

**AUTO:** allows the selected comfort level to be best attained, depending on the exterior conditions. Press button **8**. The integrated indicator light on button **8** comes on.

## Adjusting the ventilation speed

In automatic mode, the system uses the most suitable amount of air to reach and maintain the desired comfort level.

You can still adjust the ventilation speed by turning control **1** to increase or reduce the ventilation speed.

## AUTOMATIC AIR-CONDITIONING (2/4)

43355



### Adjusting the air temperature

Turn control **3** to obtain the desired temperature.

**Note:** the highest and lowest settings allow the system to produce maximum hot or cold temperature levels (“Lo” and “Hi”).

### Switching air conditioning on or off

In automatic mode, the system switches the air conditioning system on or off, depending on the climate conditions.

Press switch **4** to force activation (the warning light above comes on) or stop the air conditioning (the warning light above goes out).

Some buttons have an operating tell-tale which indicates the operating status.

The displayed temperature values show a comfort level.

When starting the engine, increasing or decreasing the value displayed will not allow the comfort level to be reached any more quickly. The system will always optimise the temperature increase or decrease (the ventilation system does not start instantly at maximum speed: it gradually increases). This may take several minutes.

Generally speaking, unless there is a particular reason not to, the dashboard air vents should remain open.

## AUTOMATIC AIR-CONDITIONING (3/4)

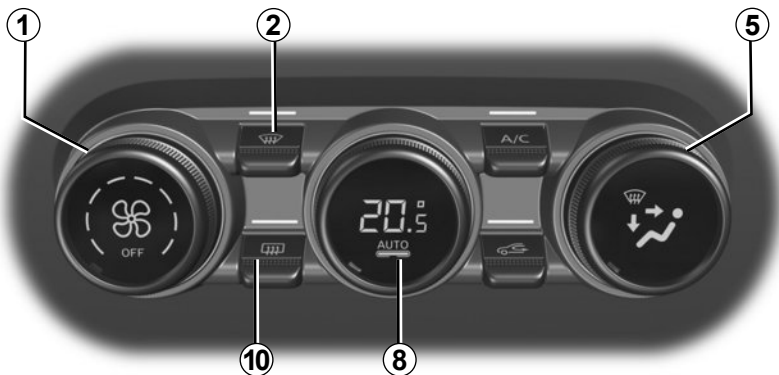

### Clear View function

Press button **2**: the indicator light above comes on.

This function quickly demists and de-ices the windscreen, the rear screen, the front side windows, and the door mirrors (depending on the vehicle). It automatically activates the air conditioning and rear screen de-icing functions.

Press button **10** to stop the heated rear screen operating. The indicator light above goes out.

**To exit this function**, press button **2** or **8** or adjust the ventilation speed by turning control **1**.

### Rear screen de-icing/ demisting

Press button **10**: the indicator light above comes on. This function enables rapid demisting or de-icing of the rear screen and de-icing of the rear view mirrors (on equipped vehicles).

**To exit this function**, press button **10** again. Demisting automatically stops.

### Adjusting the distribution of air in the passenger compartment

Turn the **5** control according to the distribution of air required. The integrated warning light in the button comes on.

It is possible to combine two positions at the same time.



All the air is then directed to the windscreen and front side window demisting vents.



The air flow is distributed between front side window demisting vents, the windscreen demisting vents and the footwells.



The air flow is directed mainly towards the footwells.



The air flow is directed to the dashboard vents and the footwells.



All the air flow is directed to the dashboard vents.

43355

# AUTOMATIC AIR-CONDITIONING (4/4)

43355



## Air recirculation (isolation of the passenger compartment)



This function is managed automatically but you can also activate it manually. In this case, operation is confirmed by a warning light above button **7**.

The demisting/de-icing will still take priority over the air recirculation.

### NB:

- during recirculation, air is taken from the passenger compartment and is recycled, with no air being taken from outside the vehicle;
- air recirculation allows the external atmosphere to be cut off (when driving in polluted areas, etc.);
- bringing the passenger compartment to the desired temperature as quickly as possible.

## Manual use

Press button **7**: the indicator light above comes on.

Prolonged use of this position may lead to odours, caused by non-renewal of air, and the formation of condensation on the windows.

We therefore advise you to return to automatic mode as soon as air recirculation is no longer needed, by pressing button **7**.

To exit this function, press button **7** again.

## Stopping the system

Turn the control **1** to “OFF” to stop the system. To start, turn control **1** again to adjust the blower speed or press button **8**.

Fuel consumption increases when the air conditioning is being used (switch it off when it is not required).



# AIR CONDITIONING: information and operating instructions (1/2)

## Advice on use

In some situations (air conditioning off, air recirculation activated, ventilation speed at zero or low etc.), you may notice that condensation starts to form on the windows and windscreen.

If there is condensation, use the “**Clear View**” function to remove it, then use the air conditioning in automatic mode to stop it forming again.

### Vehicles equipped with mode ECO

Once activated, ECO mode may reduce air conditioning performance. Please refer to the information on “Driving advice, Eco-driving” in Section 2.



Do not add anything to the vehicle's ventilation circuit (for example, to remove bad odours).

**There is a risk of damage or of fire.**

## Fuel consumption

You will normally notice an increase in fuel consumption (especially in town) when the air conditioning is operating. For vehicles fitted with air conditioning with no automatic mode, switch off the system when it is not required.

### Advice for reducing consumption and helping to preserve the environment

Drive with the air vents open and the windows closed. If the vehicle has been parked in the sun, open the doors for a few moments to let the hot air escape before starting the engine.

## Maintenance

Refer to the Maintenance Document for your vehicle for the inspection frequency.

Use the air conditioning system regularly, even in cold weather, running it at least once a month for approximately 5 minutes.

## Operating faults

As a general rule, contact your approved dealer in the event of an operating fault.

### – Reduction in de-icing, demisting or air conditioning performance.

This may be caused by the passenger compartment filter cartridge becoming clogged.

### – No cold air is being produced.

Check that the controls are set correctly and that the fuses are sound. Otherwise, switch off the system.

## Presence of water under the vehicle

After prolonged use of the air conditioning system, it is normal for water to be present under the vehicle. This is caused by condensation.



**Do not open the refrigerant fluid circuit.** The fluid may damage eyes or skin.

## AIR CONDITIONING: information and operating instructions (2/2)

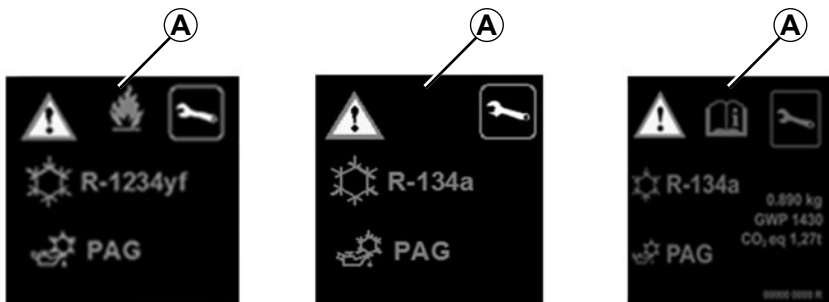

The refrigerant fluid circuit (of which some components are hermetically sealed) contains fluorinated greenhouse gases.

Depending on the vehicle, you will find the following information on label **A** affixed inside the engine compartment.

The presence and location of the information on label **A** depends on the vehicle.



**Do not open the refrigerant circuit.** The fluid may damage eyes or skin.



Before performing any action in the engine compartment, the ignition must be switched off (please see the information on “Starting, stopping the engine” in Section 2).



Type of refrigerant fluid



Type of oil in the air conditioning circuit



Inflammable product



Consult the driver's handbook



Maintenance

x.xxx kg

Quantity of refrigerant fluid present in the vehicle.

GWP xxxxx

Global Warming Potential (CO<sub>2</sub> equivalent).

CO<sub>2</sub> eq  
x.xx t

Quantity in weight and in CO<sub>2</sub> equivalent.

## ELECTRIC WINDOWS (1/3)

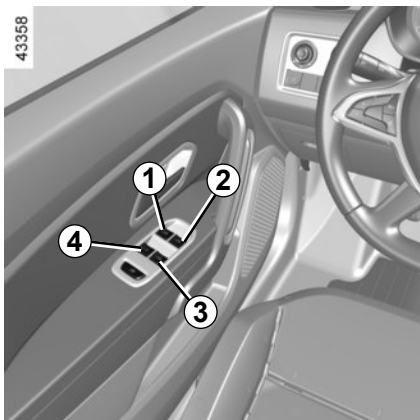

### Electric windows

With the ignition on and, depending on the vehicle, the engine running, press the switch to lower the window to the required level.

Lift the switch to raise the window to the desired height.

The system functions with the ignition off until one of the front doors is opened (limited to approximately 3 minutes).

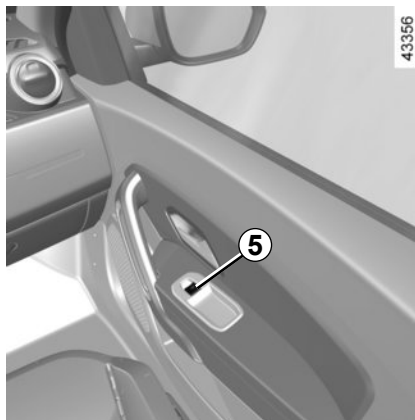

### From the driver's seat

Operate the switches as follows:

- 1 for the driver's side;
- 2 for the front passenger side;
- 3 or 4 for the rear passengers.

### From the front passenger seat

Press switch 5.

Avoid resting any objects against a half-open window: there is a risk that the electric window winder could be damaged.

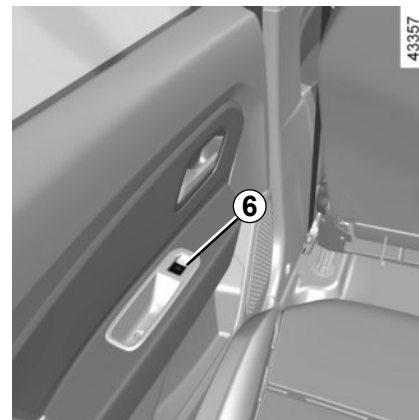

### From the rear seats

Press switch 6.



When closing the windows, ensure that no part of the body (arm, hand, etc.) is protruding from the vehicle.

**Risk of serious injury.**

## ELECTRIC WINDOWS (2/3)

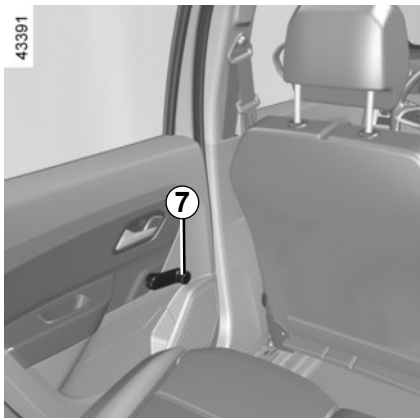

### Manually operated rear windows

Turn the handle 7 to lower or raise the window to the desired height.

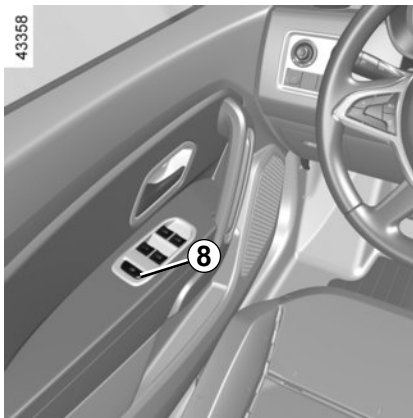

### Safety of rear occupants

Depending on the vehicle, the driver can disable the operation of the rear electric windows by pressing switch 8.

### Driver's responsibility

Never leave your vehicle with the key inside, and with a child, adult who is not self-sufficient or a pet, even for a short while. They may pose a risk to themselves or to others by starting the engine or activating equipment (such as the gear lever or electric windows). If any part of the body becomes trapped, reverse the direction of the window immediately by pressing the relevant switch.

**Risk of serious injury.**

## ELECTRIC WINDOWS (3/3)

### One-touch mode

When the vehicle is equipped with this function, the one-touch mode works in addition to the operation of the electric windows described previously.

It is only fitted to the driver's window.

- Fully and briefly press down on the relevant switch down: the window will open completely.
- Briefly raise the switch concerned fully: the window is raised completely.

Pressing the switch again while the window is moving will stop its movement.

### Special features

If the window detects resistance when closing (e.g.: branch of a tree, etc.) it stops and then lowers again by a few centimetres.

If you use the switch while the window is moving, it stops working.

### Operating faults

In case of a fault when closing a window, the system reverts to normal mode: pull the switch concerned up until the window is fully closed, then hold the switch (still on the closure side) for approximately 3 seconds, then lower the window and hold the switch (still on the opening side) for approximately 3 seconds. The window closes completely by itself and the system is reset.

If necessary, contact an approved Dealer.



When closing the windows, ensure that no part of the body (arm, hand, etc.) is protruding from the vehicle.

**Risk of serious injury.**

Avoid resting any objects against a half-open window: there is a risk that the electric window could be damaged.

## INTERIOR LIGHTING (1/2)

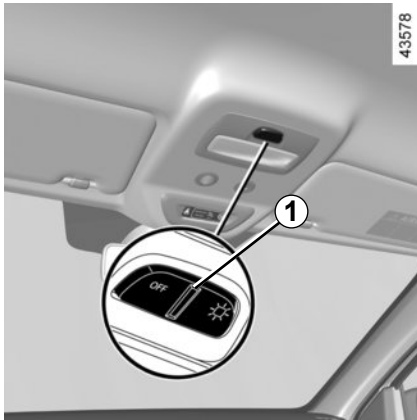

### Courtesy light

Pressing switch **1** provides:

- continuous lighting;
- or temporary lighting by opening one of the front doors, or by opening one of the four doors, depending on the vehicle. The light only goes out when the doors are correctly closed;
- no lighting.

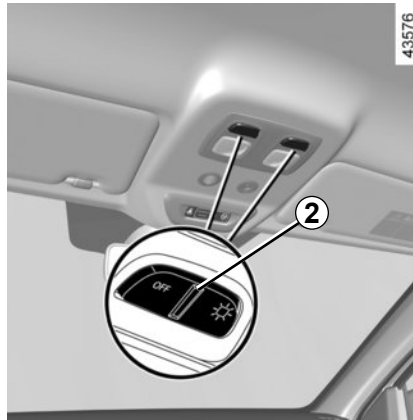

### Map reading lights

(depending on vehicle)

Pressing switch **2** provides:

- continuous lighting;
- or temporary lighting by opening one of the front doors, or by opening one of the four doors, depending on the vehicle. The light only goes out when the doors are correctly closed;
- no lighting.



## INTERIOR LIGHTING (2/2)

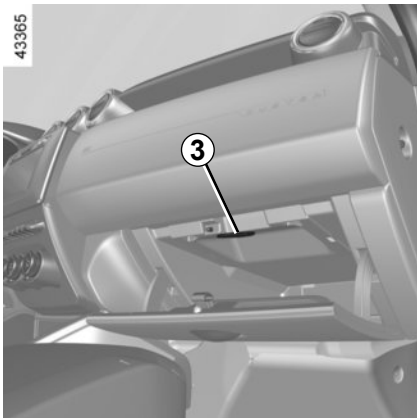

### Glovebox light 3

Light **3** comes on when the cover is opened.

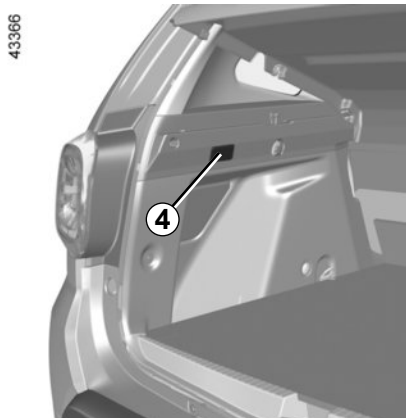

### Boot light 4

The light **4** comes on when the boot is opened.

### Automatic operation of interior lighting

(depending on vehicle)

- if the doors are unlocked using the remote control, the lighting is switched on for approximately 30 seconds.
- If a door is open (or not properly closed), the lighting is switched on for approximately 3 to 30 minutes.
- if all the doors are closed, the lighting start to dim when the ignition is switched on.

## SUN VISOR, GRAB HANDLE

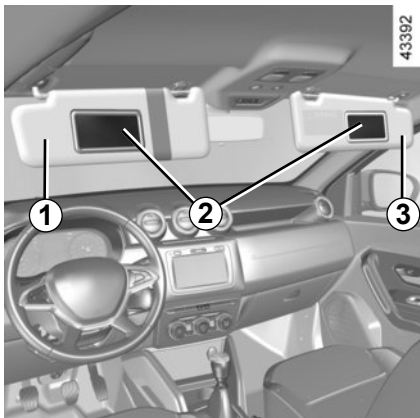

### Sun visor 1 and 3

Lower the sun visor **1** or **3** over the windscreen or unclip it and turn it over the side window.

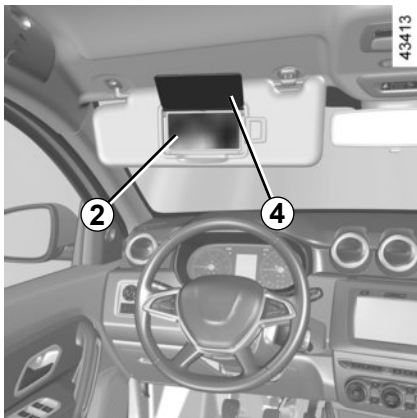

### Courtesy mirrors 2

Depending on the vehicle, the sun visors are fitted with a courtesy mirror.

Lift the cover **4**.

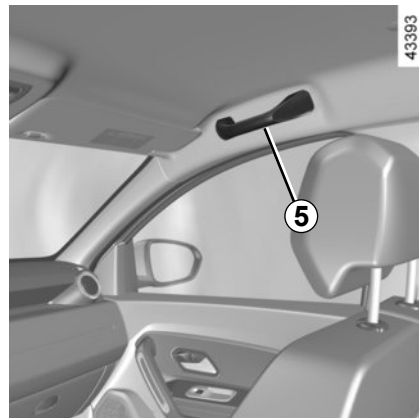

### Grab handle 5

This offers support and can be held when the vehicle is being driven.

Do not use these for getting into or out of the vehicle.



## ASHTRAYS, CIGARETTE LIGHTER, ACCESSORIES SOCKET (1/2)

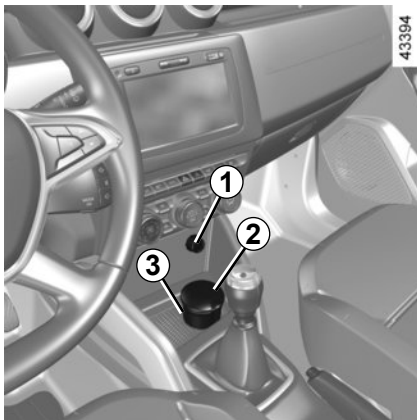

### Cigarette lighter 1

With the ignition on, push in cigar lighter **1**.

It will spring back with a click when it is ready. Pull it out to use. After use, replace it without pushing it all the way in.

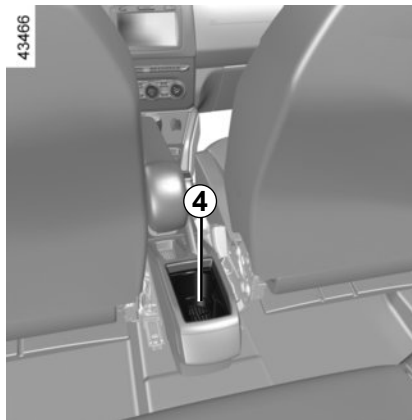

### Ashtray

It can be housed in either position **3** or **4**.

Lift the cover **2** to open.

Remove the ashtray to empty it.

If your vehicle is not fitted with a cigar lighter and an ashtray, these can be obtained from an approved Dealer.

## ASHTRAYS, CIGARETTE LIGHTER, ACCESSORIES SOCKET (2/2)

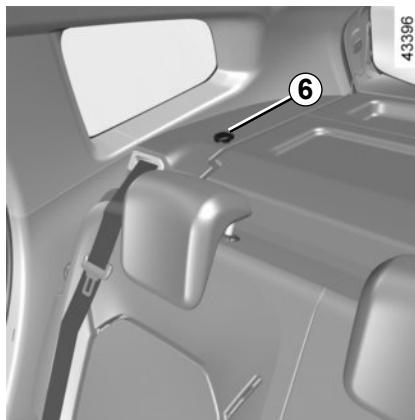
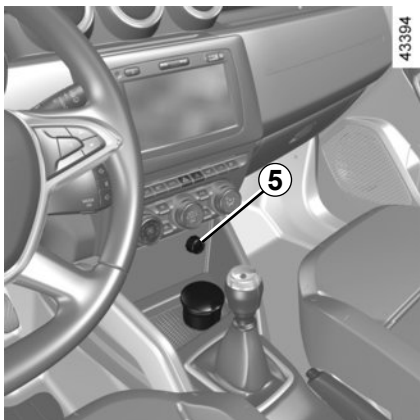

### Accessories sockets 5 and 6

The sockets are provided to connect accessories approved by our Technical Department.



Connect accessories with a maximum power of 120 Watts (12 V) only.

When several accessory sockets are used at the same time, the total power of the connected accessories must not exceed 180 watts.

**Fire hazard.**

## REAR HEADRESTS (1/2)

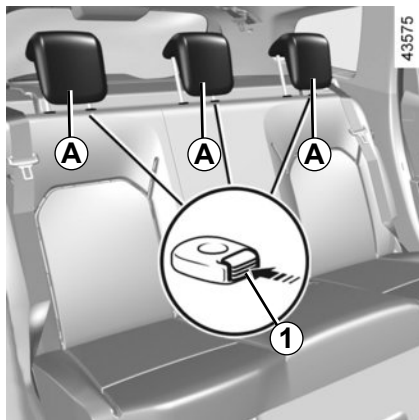

### Five-seater version

#### Position for using headrest A

Lift the headrest fully until it locks. Check that the bonnet is correctly locked.

#### To raise the headrest A

Raise the headrest as far as it will go, then press button 1 and remove the headrest.

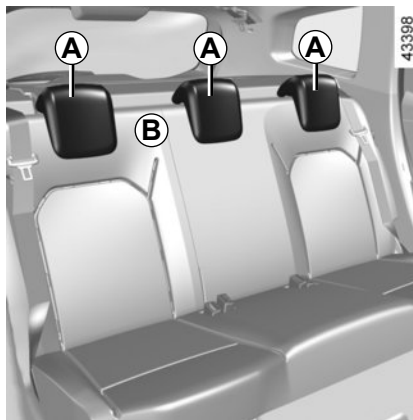

**To put the headrest back in place A**  
Insert the rods in the holes, press button 1, lower the headrest and check that it is securely in place.

#### Headrest storage position A

Press the button 1 and lower the headrest completely.

**The lowest position of the headrest (position B) is a position for storage only:** do not set it in this position when the seat is occupied.

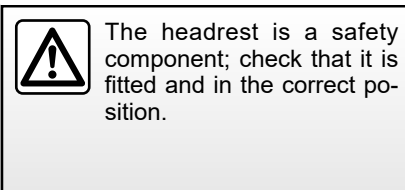
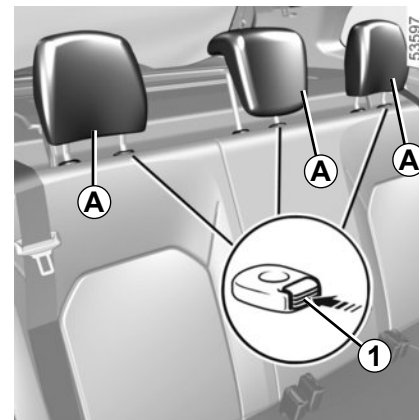

## REAR HEADRESTS (2/2)

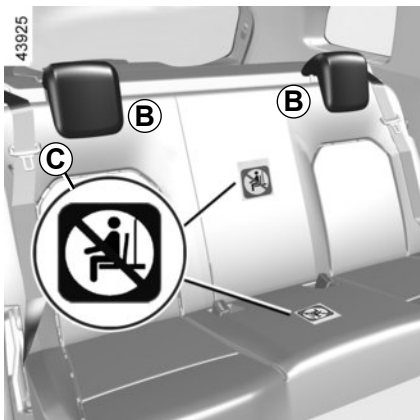

### Four-seater version

This version differs in that it has rear seatbelts and headrests on the rear side seats only.

The **C** label informs you that it is prohibited to seat passengers in areas other than the seats provided.

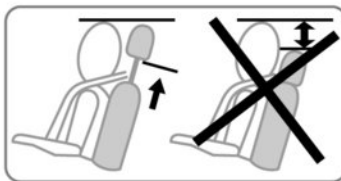

The lowest position of the headrest (position **B**) is a position for storage **only**: do not set it in this position when the seat is occupied.



The headrest is a safety component; check that it is fitted and in the correct position.

## PASSENGER COMPARTMENT STORAGE SPACE AND FITTINGS (1/5)

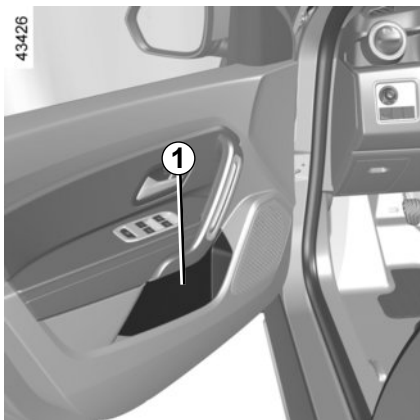

**Front door storage compartments 1**

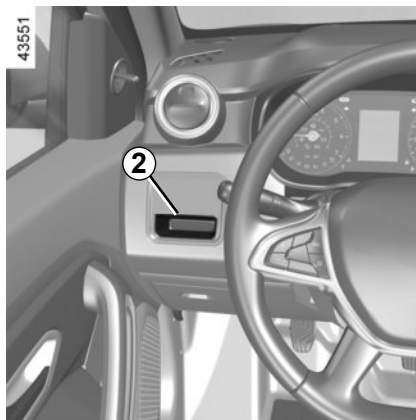

**Dashboard storage 2**

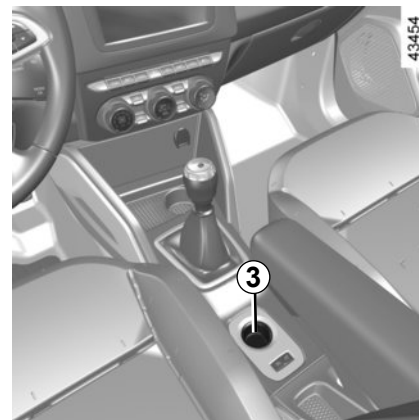

**Central storage compartment 3**



Nothing should be placed on the floor area in front of the driver as such objects may slide under the pedal during braking manoeuvres, thus obstructing its use.



Ensure that no hard, heavy or pointed objects are placed in the “open” storage compartments in such a way that they may fall onto passengers during sudden turning, braking or in the event of an accident.

## PASSENGER COMPARTMENT STORAGE SPACE AND FITTINGS (2/5)



**Centre console storage compartment 4**  
(or radio location)

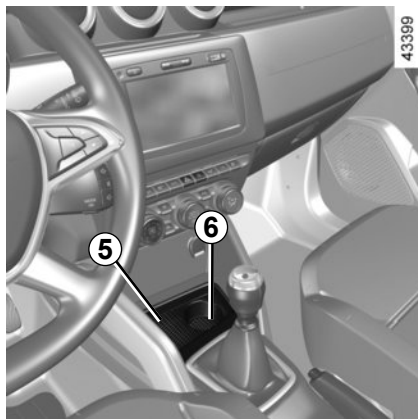

**Central storage compartment 5**

**Place for cups or ashtray 6**

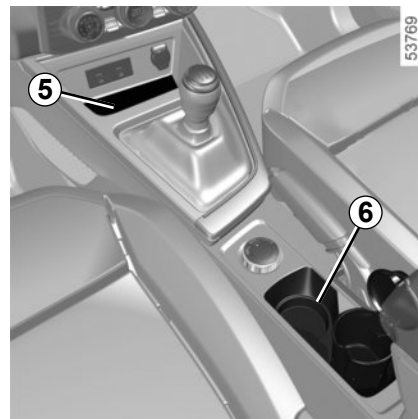

Ensure that no hard, heavy or pointed objects are placed in the “open” storage compartments in such a way that they may fall onto passengers during sudden turning, braking or in the event of an accident.

## PASSENGER COMPARTMENT STORAGE SPACE AND FITTINGS (3/5)

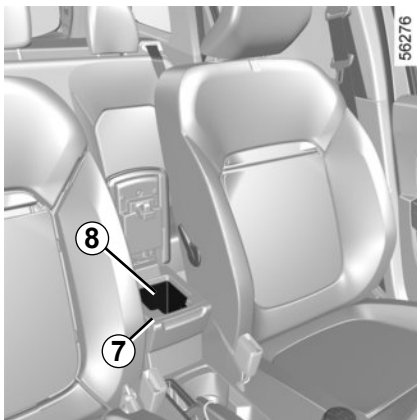

### Central storage compartment 8

With the sliding armrest 7 in its rear-most position, raise it.

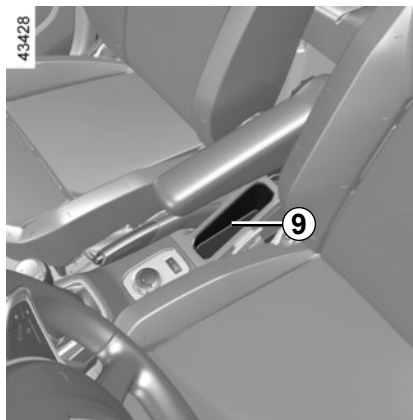

### Central storage compartment 9

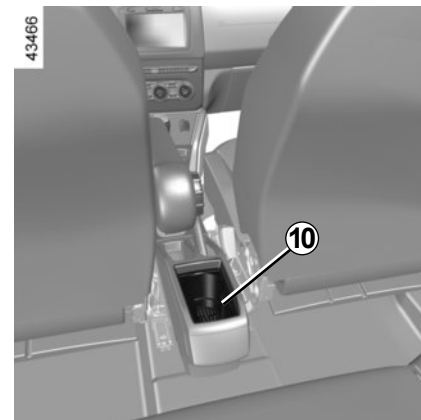

### Cup holders 10

This can be used for storing a mobile ashtray, cup holder, etc.



When cornering, accelerating or braking, ensure that the cup does not spill.

**There is a risk of burns if hot liquid leaks.**

## PASSENGER COMPARTMENT STORAGE SPACE AND FITTINGS (4/5)

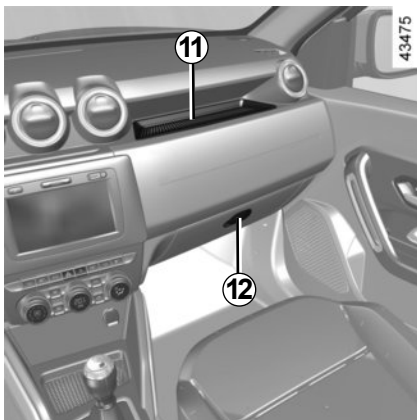

**Dashboard upper storage compartment 11**

### **Passenger side glove box**

Pull handle **12** to open it.

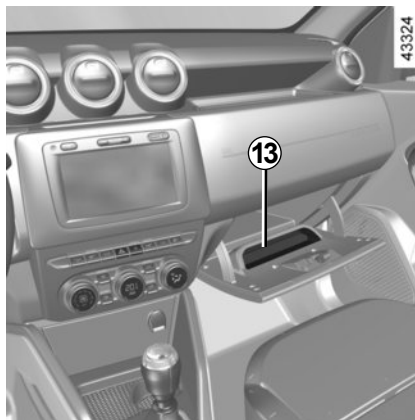

This glove box can be used to store A4 format documents.

Inside the cover, section **13** has been provided for pens, maps, etc.

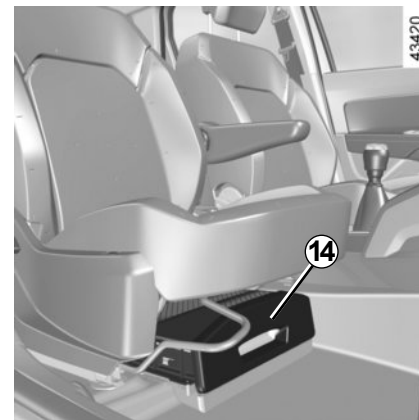

**Storage drawer under passenger seat 14**



Nothing should be placed on the floor area in front of the driver as such objects may slide under the pedal during braking manoeuvres, thus obstructing its use.



## PASSENGER COMPARTMENT STORAGE SPACE AND FITTINGS (5/5)

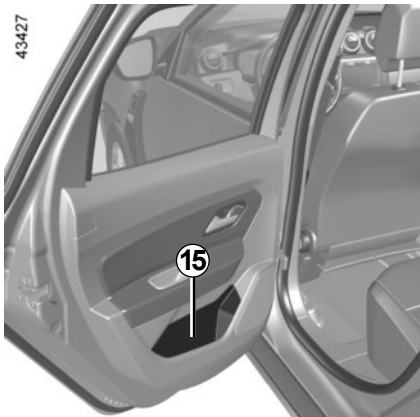

**Rear door storage compartment 15**

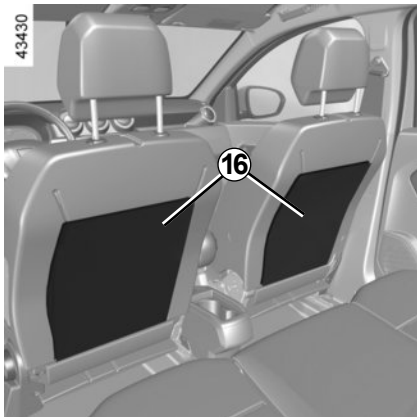

**Front seat storage pockets 16**



Ensure that no hard, heavy or pointed objects are placed in the “open” storage compartments in such a way that they may fall onto passengers during sudden turning, braking or in the event of an accident.

## REAR BENCH SEAT (1/3)

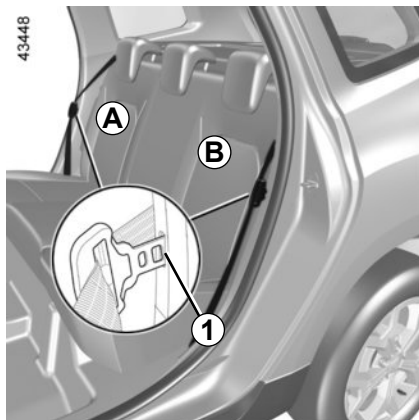

### Five-seater version

#### To fold the back **A** or **B**

- Insert the seat belt buckle of the rear seat in its housing **1**;
- remove or fully lower the headrests (please see the information on “Rear headrests” in Section 3);
- lower handle **2**;
- lower the seat back.



For safety reasons, carry out any adjustments when the vehicle is not being driven.

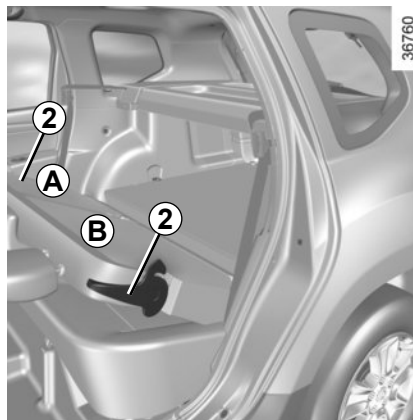

### To reposition the seat back **A** or **B**

- Lift the seat back;
- make sure you lock the seat back in place.



Check that the rear seat belts are positioned and operating correctly each time the rear bench seat is moved.



**When refitting the seat-back**, make sure it is correctly locked in place.

**If seat covers are fitted**, make sure these do not prevent the seatback latch from locking in. Make sure that the seat belts are positioned correctly. Reposition the headrests.



When moving the rear bench seat, ensure that nothing obstructs the anchorage points (part of the body, a pet, gravel, cloth, toys, etc.).

## REAR BENCH SEAT (2/3)

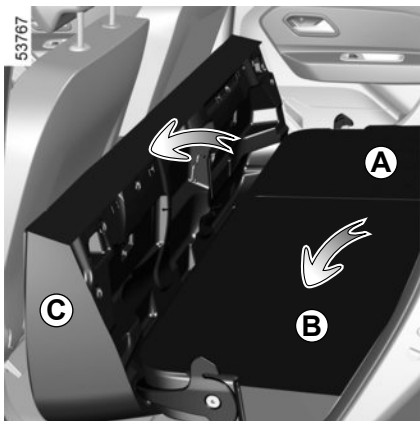

**To fold-down the seat C**  
(depending on vehicle)

Ensure that the front seats are far enough forward.

Tilt seat base **C** against the front seats.

**To fold-down/reposition the seatback A or B**

Proceed as described above.

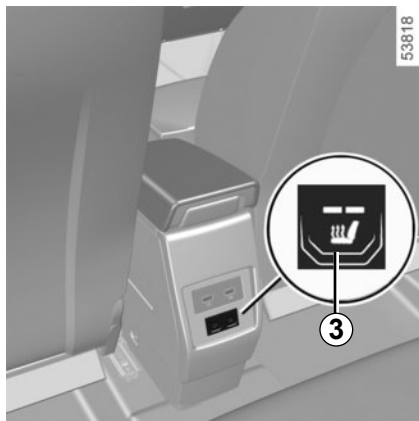

**Heated seats**  
(depending on vehicle)  
Side seats only

With the ignition on:

- pressing the switch **3** on the required seat for the first time activates the heating system on high. Both integrated switch warning lights come on;
- pressing the switch for the second time changes the heating to low. One integrated warning light comes on;
- pressing for the third time turns the heating off.

The system automatically regulates the seat temperature. When activated, it will determine if the seat heating is necessary or not.



Check that the rear seat belts are positioned and operating correctly each time the rear bench seat is moved.

## REAR BENCH SEAT (3/3)

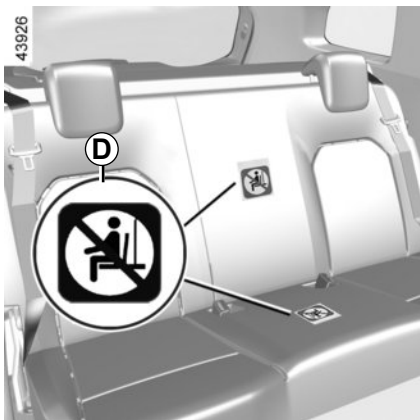

### Four-seater version

This version differs in that it has rear seatbelts and headrests on the rear side seats only.

**The D label informs you that it is prohibited to seat passengers in areas other than the seats provided.**



Check that the rear seat belts are positioned and operating correctly each time the rear bench seat is moved.

# TAILGATE

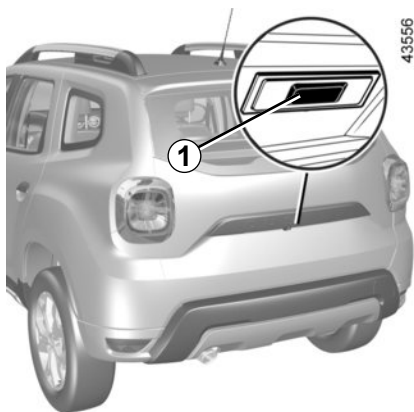

## To open

Press button **1** and lift the tailgate.

## To close

Lower the tailgate using handles **2** inside the tailgate to help you.

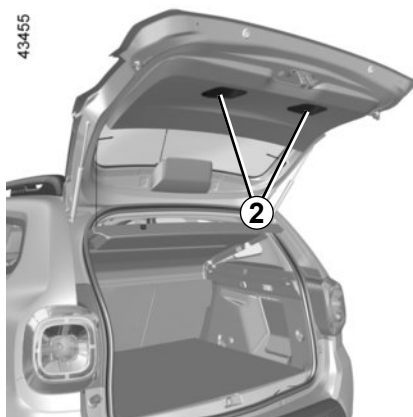

## Electric central locking

The tailgate is locked and unlocked at the same time as the doors.

Once you have lowered the tailgate to shoulder height, release the interior handle and finish closing the tailgate by pressing down on the tailgate from the outside.



The attaching of any carrying device (bike rack, luggage box, etc.) resting on the luggage compartment lid is prohibited. To install a carrying device on your vehicle, contact an Approved Dealer.

## TRANSPORTING OBJECTS IN THE BOOT (1/2)

Always position the objects transported so that the largest surface is against:

- the rear bench seatbacks, for normal loads (example: **A**);

433463



- the front seatbacks with the rear seatbacks folded down, as is the case for maximum loads (example **B**).

433465

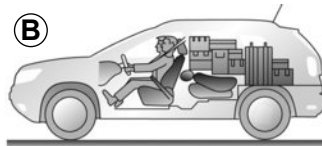

Ensure that the objects being transported are evenly distributed throughout the loading area.

If you have to place objects on the folded seatback, it is necessary that you lower the headrests before folding the seatback so that it can be folded as flat as possible against the seat.

## TRANSPORTING OBJECTS IN THE BOOT (2/2)

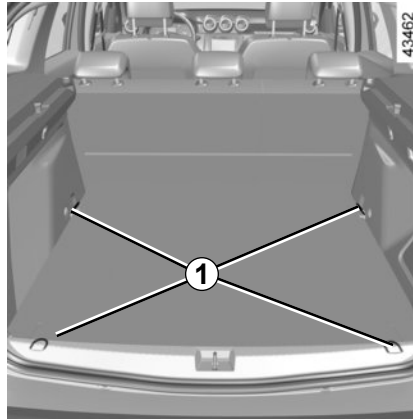
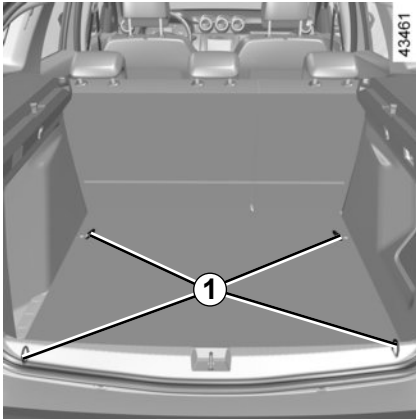

Always position the heaviest items directly on the floor. Use the lashing points **1** on the boot floor, if these are fitted to the vehicle. The luggage should be loaded in such a way that no items will be thrown forward and strike the occupants if the driver has to brake suddenly. Fasten the rear seat belts, even if the seats are not occupied.

## TRANSPORTING OBJECTS towing, attachments

### Permissible nose weight, maximum permissible towing weight braked and unbraked :

Refer to the information on "Weights" in Section 6.

### Choice and fitting of towing equipment

Maximum weight of towing equipment: 25 kg.

It is not permitted to fit a mechanical towing device (ball, hook, etc.) that is removable without tools or retractable if it cannot be easily removed or repositioned when not in use.

For information on how to fit the towing equipment and the conditions of use, refer to the fitting instructions.

Please keep these instructions with the rest of the vehicle documentation.

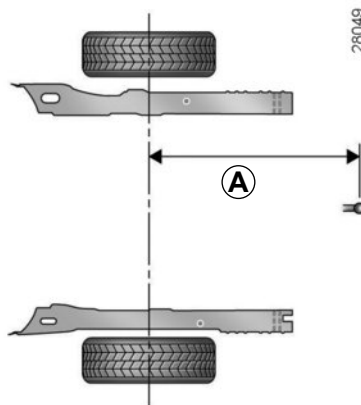

Maximum dimension **A = 955 mm**

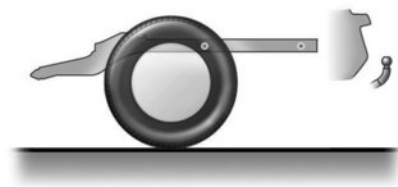

Any towing device must not obstruct any lighting component or the number plate when not in use. Mechanical towing devices (ball, hook, etc.) which can be removed without tools or which are retractable must be removed or repositioned when they are not in use.

In all cases, you must comply with the regulations of the particular country you are in.



## REAR PARCEL SHELF

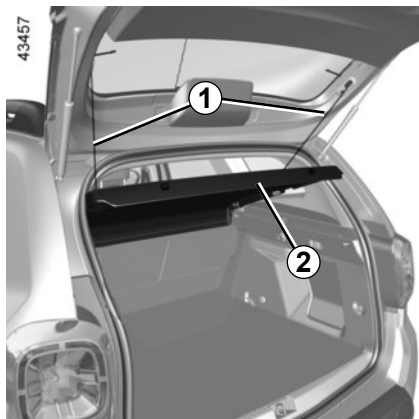

### Removal

Unhook the two cords **1** from the boot door.

The parcel shelf **2** is made up of two rigid sections.

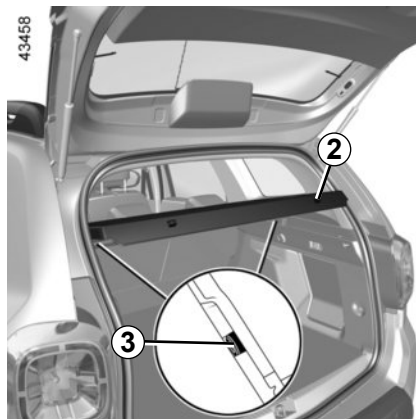

Lift the parcel shelf **2** to half height and unclip the mountings **3** located on each side of the parcel shelf.

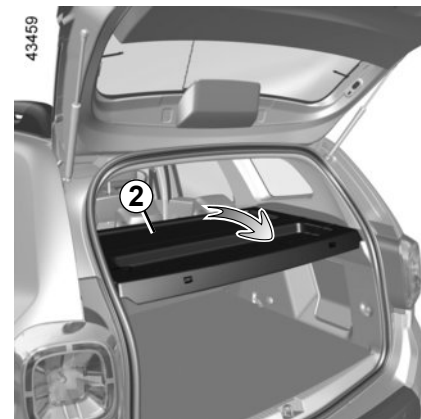

Gently lift the parcel shelf **2** and pull it towards you, holding it at each end.

To refit, proceed in the reverse order to removal.



Do not place any heavy or solid objects on the parcel shelf.

These may pose a risk to the vehicle occupants if the driver has to brake suddenly or if the vehicle is involved in an accident.

## ROOF BARS, SPOILER (1/4)

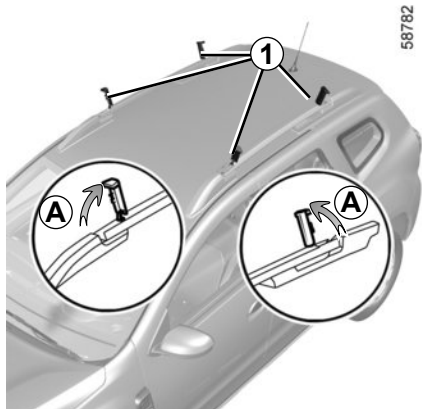

### Modular roof bars

If the vehicle is equipped, this device enables you to position the roof bars in either longitudinal or transverse position.

#### To place the bars in the transverse position:

- unclip the rotary covers **1** and put them in the vertical position (movement **A**);
- loosen the bolts **2** using the torque wrench **6** (see following pages) located in the glove box;

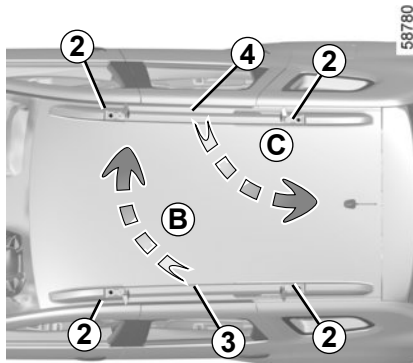

- raise the bars **3** and **4** and fit them in transverse position **5**. To do this, place the bar **3** (movement **B**) in the front position, then place the bar **4** (movement **C**) in the rear position.

**Note:** make sure that bars **3** and **4** are correctly positioned.

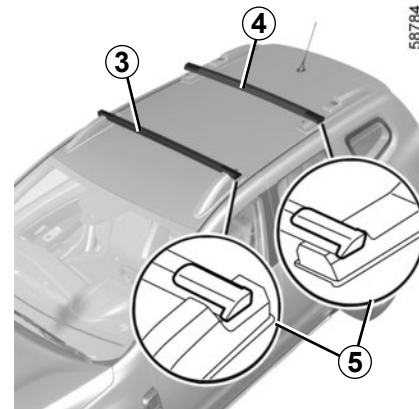

**Maximum permissible load on roof rack:** refer to the information on “Weights” in Section 6.



It is forbidden to attach any carrying device on the roof for vehicles not originally fitted with longitudinal or modular roof bars.

## ROOF BARS, SPOILER (2/4)

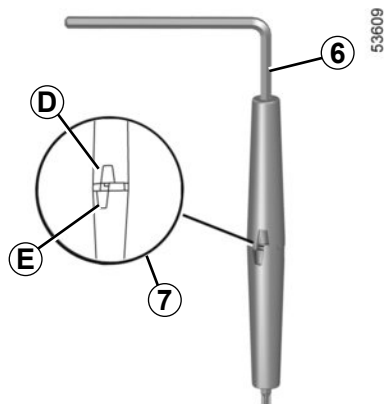

- use the **6** tool to tighten the bolts **2**: marks **D** and **E** located on the tool should be out-of-synch (mark **7**);
- tighten the bolts **2** as far as possible using the tool **6** until marks **D** and **E** located on the tool **6** are parallel (mark **8**);
- re-clip the rotary covers **1**.

**Note:** bars **3** and **4** are not interchangeable.

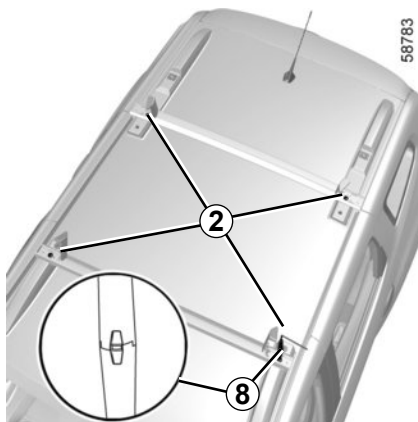

It is strictly forbidden to place the roof bars in the transverse position (carrying position) when entering a roller-type car wash.



Make sure that the two modular roof bars are correctly positioned and locked.

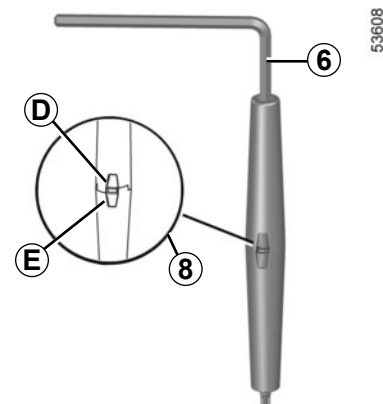

### Roof bars in the transverse position

The maximum speed must be limited to 80 mph (130 km/h).

## ROOF BARS, SPOILER (3/4)

When not using the bars in transverse position, refit the bars in longitudinal position in order to optimise fuel consumption and avoid air noise.

In the event of loss, contact an approved dealer to obtain the bolts **2** and tool **6**.



The modular roof bars are originally assembled and approved by our Technical Department.

They are supplied with bolts **2** and tool **6**. These must only be used for attaching the roof bars to the vehicle.



Check that the objects and/or accessories (bike rack, roof box etc.) fitted to the modular roof bars are correctly positioned, evenly distributed and secured.

## ROOF BARS, SPOILER (4/4)

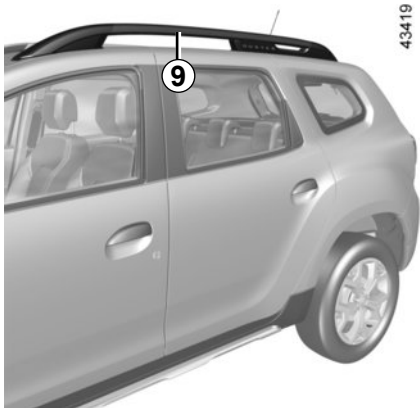

### Longitudinal roof bars

If fitted on the vehicle, you can transport luggage or additional equipment (bike racks, ski racks, etc):

- on a roof rack;
- on transverse roof bars which must in turn be attached to roof bars fitted lengthways **9**;
- directly onto the longitudinal roof bars.

For information on the range of equipment adapted to your vehicle, we advise you to consult an approved Dealer. Refer to the manufacturer's instructions for information on how to fit and operate the equipment.

Please keep these instructions with the rest of the vehicle documentation.

**Maximum permissible load on roof rack:** refer to the information on "Weights" in Section 6.



It is forbidden to attach any carrying device on the roof for vehicles not originally fitted with longitudinal or modular roof bars.



### Spoiler *F*



It is prohibited to attach any carrying equipment (bike rack, luggage box etc.) resting against the spoiler or tailgate. To install a carrying device on your vehicle, contact an Approved Dealer.

## MULTIMEDIA EQUIPMENT (1/3)

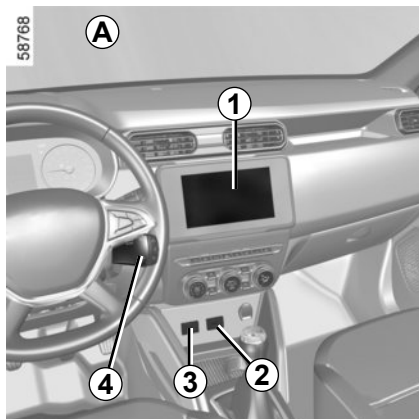

### Multimedia system A or B

The presence and location of this equipment depends on the vehicle's multimedia equipment.

- 1 Multimedia screen;
- 2 Multimedia socket;
- 3 Charging socket;
- 4 Steering column controls.

Please refer to the instruction manual for details of how it works.

### Multimedia socket 2

You can use the USB socket to access the multimedia content of your accessories and to update the system.

The various sources can be selected using the multimedia screen or the radio and the steering column controls.

The sockets USB can also be used to recharge accessories with a maximum power rating of 12 Watts (5 Volts) per socket, which have been approved by our Technical Department.

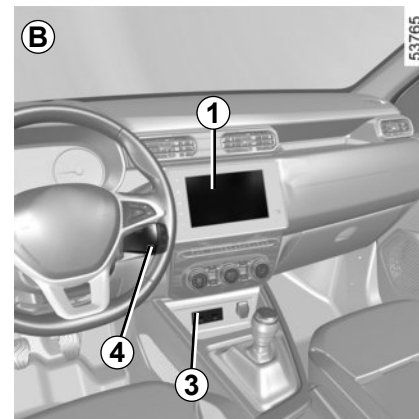

### Charging connection 3

The USB sockets can be used to recharge accessories with a maximum power rating of 12 Watts (5 Volts) per socket, which have been approved by our Technical Department.



Connect accessories with a maximum power of 12 watts only.

**Fire hazard.**

## MULTIMEDIA EQUIPMENT (2/3)

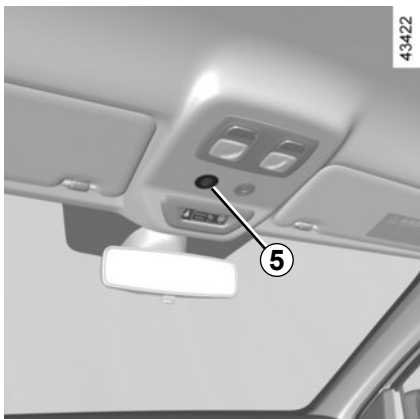

### Hands-free telephone integrated control

Use the microphone **5** or, depending on the vehicle, **6** and the steering column control **4**.

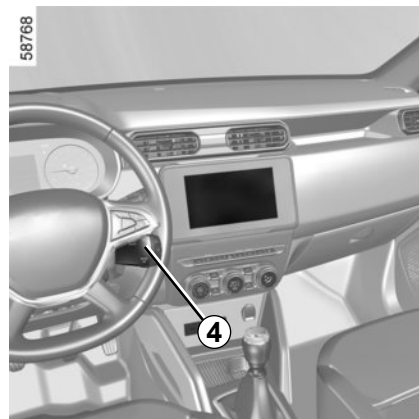

#### Using the telephone

We remind you of the need to conform to the legislation in force concerning the use of such equipment.

## MULTIMEDIA EQUIPMENT (3/3)



### Rear sockets 7

USB sockets only allow the recharging of accessories approved by the brand's Technical Services for which the power must not exceed 12 watts (5 volts) per outlet.



Connect accessories with a maximum power of 12 watts only.

**Fire hazard.**



### Radio 8

Please refer to the multimedia instructions for further information.



# Section 4: Maintenance

Bonnet . . . . .	4.2
Engine oil level: general information . . . . .	4.4
Engine oil level: topping up, filling . . . . .	4.6
Levels . . . . .	4.10
Brake fluid level . . . . .	4.10
Engine coolant . . . . .	4.11
Filters . . . . .	4.13
Tyre pressure . . . . .	4.14
Battery . . . . .	4.16
Bodywork maintenance . . . . .	4.18
Interior trim maintenance . . . . .	4.21

## BONNET (1/2)



To open, pull the handle **1** or, depending on the vehicle, the **2** stalk.



Before performing any action in the engine compartment, the ignition must be switched off (please see the information on “Starting, stopping the engine” in Section 2).



Deactivate the Stop and Start function for any operation performed in the engine compartment.

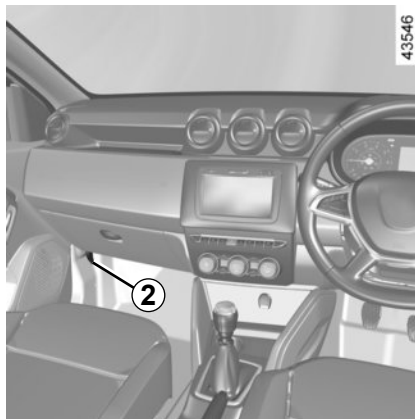

Please note when working close to the engine that it may be hot. The engine cooling fan may also start

at any moment. The  warning light in the engine compartment reminds you of this.

**Risk of injury.**



When working in the engine compartment, ensure that the windscreen wiper stalk is in the park position.

**Risk of injury.**



Never activate the remote engine start-up function or its programming before opening the bonnet or when it is open.

**Risk of burns or serious injury.**



Do not press down on the bonnet: there is a risk that the bonnet may accidentally close.

## BONNET (2/2)

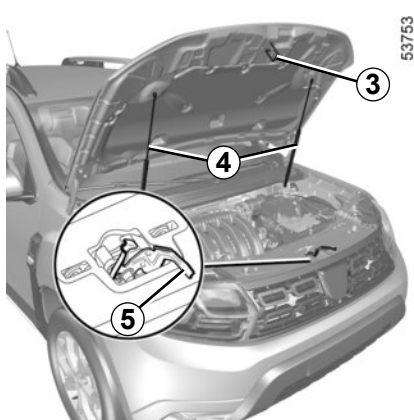

### Unlocking the bonnet catch

To unlock, raise the bonnet slightly and release hook **3** by pushing tab **5** to the left.

### Opening the bonnet

Lift the bonnet, guiding it up, and it will rest in position with the help of two struts **4**.

Depending on the vehicle, lift the bonnet and release the stay **6** from its holder **7**. For your own safety, it is **very important** to fix the stay into the retainer **8** in the bonnet.

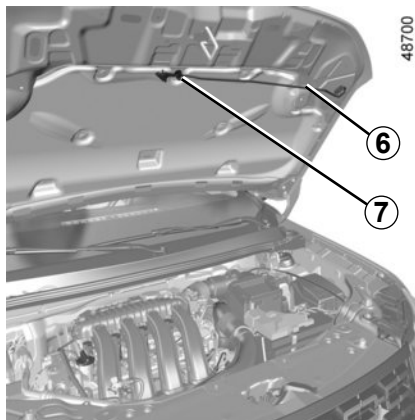

### Closing the bonnet

Check that nothing has been left in the engine compartment.

Depending on the vehicle, to close the bonnet, replace the stay **6** in its holder **7**. Hold the middle of the bonnet and guide it down to one foot (30 cm) above the closed position, then release. It will latch automatically under its own weight.



Ensure that the bonnet is properly locked. Check that nothing is preventing the catch from locking (gravel, cloth, etc.).

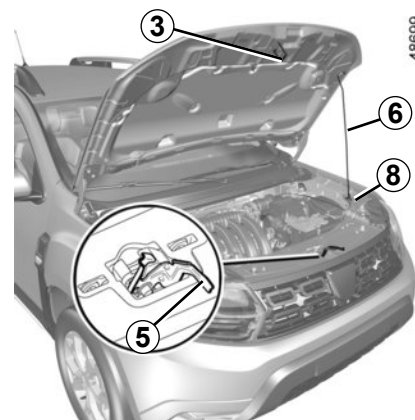

Make sure nothing is left in the engine compartment (cloth, tools, etc.).

Otherwise, this may lead to engine damage or cause a fire.



In the event of even a slight impact involving the radiator grille or bonnet, have the bonnet lock checked by an approved Dealer as soon as possible.

## ENGINE OIL LEVEL: general information (1/2)

It is normal for an engine to use oil for lubrication and cooling of moving parts and it is normal to top up the level between oil changes.

However, contact your approved Dealer if more than 0.5 litres is being consumed every 600 miles (1,000 km) after the running in period.

**Oil change frequency: check the oil level from time to time and certainly before any long journey to avoid the risk of damaging your engine.**

Consult your approved dealer at once if you notice an abnormal or repeated drop in any of the fluid levels.



Deactivate the Stop and Start function for any operation performed in the engine compartment.



### Adding engine oil

Use a funnel or protect the filling neck area to avoid engine oil escaping onto a hot part of the engine compartment or a sensitive part (e.g. electrical components).

**Fire hazard.**



Before performing any action in the engine compartment, the ignition must be switched off (please see the information on “Starting, stopping the engine” in Section 2).

## ENGINE OIL LEVEL: general information (2/2)

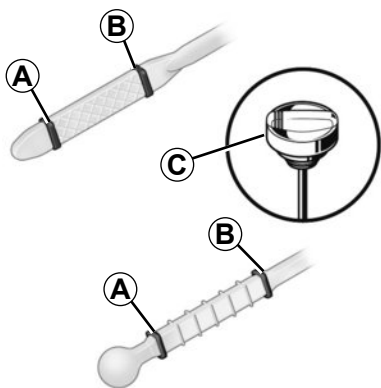

### Reading the oil level

The oil level should be read with the vehicle on level ground, after the engine has been switched off for some time.

**The dipstick must be used to read the exact oil level and make sure that the maximum level has not been exceeded (risk of engine damage). Refer to the following pages.**

Depending on the vehicle, the instrument panel display only alerts the driver when the oil level is at its minimum.

- remove the dipstick and wipe with a clean, lint-free cloth;
- push the dipstick in as far as it will go (for vehicles equipped with a cap-type dipstick **C**, screw the cap in as far as it will go);
- take out the dipstick again;
- read the level: it should never fall below minimum mark **A** or exceed maximum mark **B**.

Once the operation has been completed, ensure that the dipstick is pushed in as far as it will go or that the “cap-type dipstick” is completely screwed in.



### Exceeding the maximum engine oil level

Under no circumstances should maximum filling level **B** be exceeded: this could damage the engine and the anti-pollution system.

If the oil level exceeds the maximum level, **do not start your vehicle**. Contact an authorised dealer.

## ENGINE OIL LEVEL: topping up, filling (1/4)

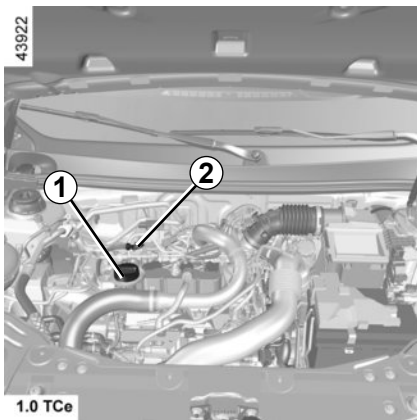

### Topping up/filling

The vehicle must be parked on level ground and the engine should be cold (for instance, before the engine is started up for the first time in the day).



Please note when working close to the engine that it may be hot. The engine cooling fan may also start

at any moment. The  warning light in the engine compartment reminds you of this.

**Risk of injury.**

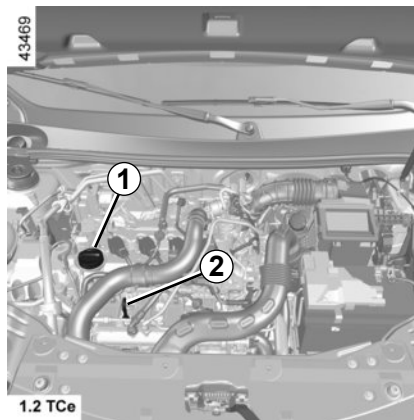

- Unscrew cap **1**;
- top up the level (as a guide, the capacity between the minimum and maximum reading on dipstick **2** is between 1.5 and 2 litres, depending on the engine);
- wait approximately 10 minutes to allow the oil to flow into the engine;
- check the level using the dipstick **2** (as described above).

Once the operation has been completed, ensure that the dipstick is pushed in as far as it will go or that the “cap-type dipstick” is completely screwed in.

Do not exceed the **MAX** level and do not forget to refit dipstick **2** and cap **1**.



Before performing any action in the engine compartment, the ignition must be switched off (please see the information on “Starting, stopping the engine” in Section 2).



**Exceeding the maximum engine oil level**

Under no circumstances should the maximum filling level be exceeded: this could damage the engine and the emission control system.

If the oil level exceeds the maximum level, **do not start your vehicle**. Contact an authorised dealer.

## ENGINE OIL LEVEL: topping up, filling (2/4)

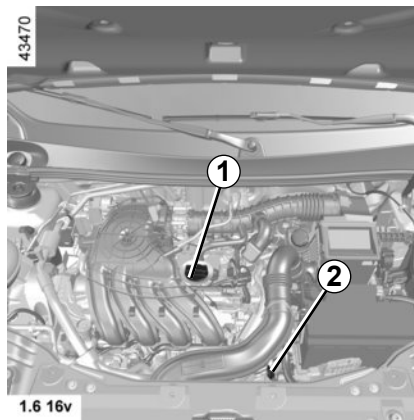
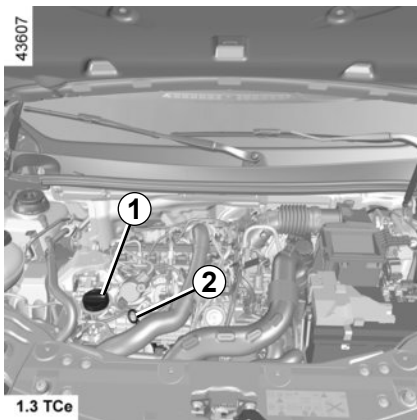

Do not exceed the **MAX** level and do not forget to refit dipstick **2** and cap **1**.



Deactivate the Stop and Start function for any operation performed in the engine compartment.



### Adding engine oil

Use a funnel or protect the filling neck area to avoid engine oil escaping onto a hot part of the engine compartment or a sensitive part (e.g. electrical components).

**Fire hazard.**



Never run the engine in an enclosed space as exhaust gases are poisonous.

## ENGINE OIL LEVEL: topping up, filling (3/4)

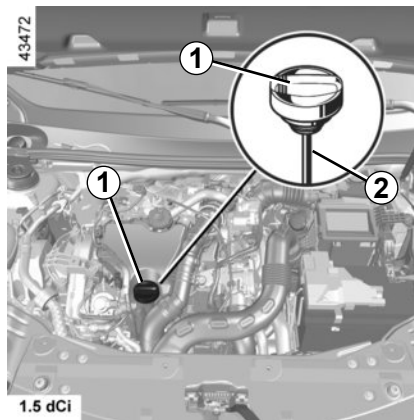
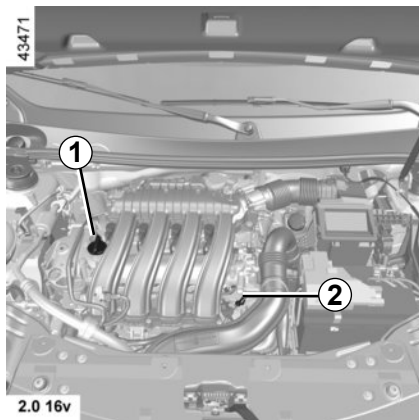

If there is an abnormal or repeated drop in the fluid level, please consult an authorised dealer.



When working in the engine compartment, ensure that the windscreen wiper stalk is in the park position.

**Risk of injury.**



**Refilling the oil or checking the oil level:** be careful when topping up or checking the level of the oil, make sure that no oil drips onto the engine components. Do not forget to properly close the cap and refit the dipstick to prevent any oil spatter on hot engine components.

**Fire hazard.**



**Engine oil change:** if you are changing the oil when the engine is hot, be careful not to scald yourself if the oil overflows.



## ENGINE OIL LEVEL: topping up, filling (4/4)

### Oil change

**Service interval:** refer to the Maintenance Document for your vehicle.

### Oil change capacity

Please refer to the maintenance document for your vehicle, or contact an authorised dealer.

Always check the engine oil level using the dipstick, as explained previously (it should never fall below the minimum level, or be over the maximum level on the dipstick).

### Engine oil grade

Refer to the Maintenance Document for your vehicle.



Deactivate the Stop and Start function for any operation performed in the engine compartment.

### Resetting the alert after an oil change

(depending on the vehicle)

If you change the oil yourself, you will need to reset the oil change warning.

To do this, after switching on the ignition, for ten seconds you must:

- Depress the accelerator pedal fully,
- with your foot on the accelerator, depress the brake pedal three times in succession.

Reinitialisation is complete when the



indicator light goes out. If this is not the case, repeat the operation.

**Special case:** if you change the oil before the engine oil change exceeded warning is displayed, it is also necessary to reset the warning. In this case,

the  warning light comes on for approximately 5 seconds to confirm the reset.



Never run the engine in an enclosed space as exhaust gases are poisonous.



Please note when working close to the engine that it may be hot. The engine cooling fan may also start

at any moment. The  warning light in the engine compartment reminds you of this.

**Risk of injury.**



**Exceeding the maximum engine oil level**

Under no circumstances should the maximum filling level be exceeded: this could damage the engine and the emission control system.

If the oil level exceeds the maximum level, **do not start your vehicle.** Contact an authorised dealer.

## LEVELS (1/3)

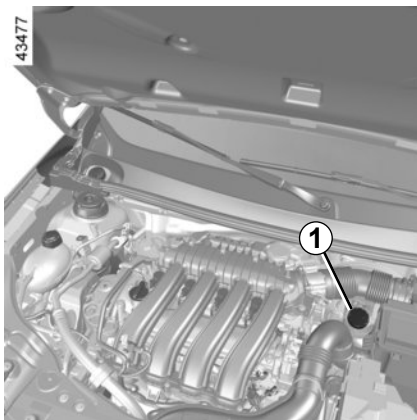

### Brake fluid

This should be checked frequently, and immediately if you notice even the slightest loss in braking efficiency.

The level should be read with the engine switched off and on level ground.



Deactivate the Stop and Start function for any operation performed in the engine compartment.

### Level

It is normal for the level to drop as the brake shoes become worn, but it must never drop lower than the “MINI” warning line shown on brake fluid reservoir **1**.

If you wish to check the disc and drum wear yourself, you should obtain the document explaining the checking procedure from the manufacturer’s network or web site.



Please note when working close to the engine that it may be hot. The engine cooling fan may also start

at any moment. The  warning light in the engine compartment reminds you of this.

**Risk of injury.**

### Topping up

After any operation on the hydraulic circuit, a specialist must replace the fluid.

Only use fluids approved by our Technical Department (and taken from a sealed container).

### Replacement intervals

Refer to the Maintenance Document for your vehicle.

If there is an abnormal or repeated drop in the fluid level, please consult an authorised dealer.



Before performing any action in the engine compartment, the ignition must be switched off (please see the information on “Starting, stopping the engine” in Section 2).

## LEVELS (2/3)

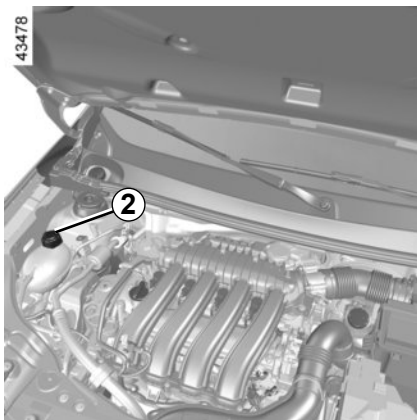

### Coolant

With the engine switched off and on level ground, the level **when cold** must be between the MINI and MAXI marks on reservoir **2**.

Top this level up **when cold** before it reaches the MINI mark.

### Coolant level checking frequency

**Check the coolant level regularly** (very severe damage is likely to be caused to the engine if it runs out of coolant).

If the level needs to be topped up, only use products approved by our Technical Department which ensure:

- protection against freezing;
- anticorrosion protection of the cooling system.

### Replacement intervals

Refer to the Maintenance Document for your vehicle.

If there is an abnormal or repeated drop in the fluid level, please consult an authorised dealer.



No operations should be carried out on the cooling circuit when the engine is hot.

**Risk of burns.**



Please note when working close to the engine that it may be hot. The engine cooling fan may also start

at any moment. The  warning light in the engine compartment reminds you of this.

**Risk of injury.**

## LEVELS (3/3)

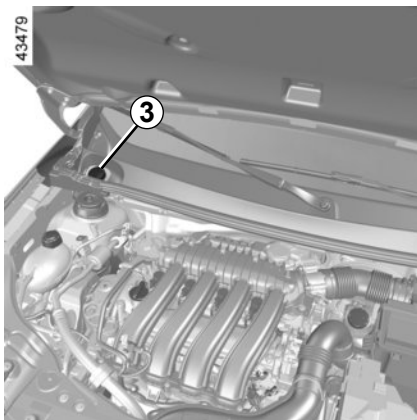

### Windscreen washer reservoir

**Filling:** With the engine switched off, open the cap **3**, fill until you can see the fluid, then refit the cap.

This reservoir supplies the front and rear screen washers.

**Liquid:** Special windscreen washer fluid (use an anti-freeze product in winter).

Use products recommended by an authorised dealer.

**Jets:** to adjust the angle of the jets, pivot the little ball using a pin.

**Note:** do not use pure water (risk of damage to the priming pump, limescale building up on the pump and the jets).



Please note when working close to the engine that it may be hot. The engine cooling fan may also start

at any moment. The  warning light in the engine compartment reminds you of this.

**Risk of injury.**

## FILTERS

The replacement of filter elements (air filter, passenger compartment filter, diesel filter, etc.) is scheduled in the maintenance operations for your vehicle.

**Replacement intervals for filter elements:** refer to the Maintenance Document for your vehicle.

### Passenger compartment filter

If your vehicle is not originally fitted with a passenger compartment filter, it is possible to have one retrofitted.

Contact an approved dealer.



Deactivate the Stop and Start function for any operation performed in the engine compartment.



When working in the engine compartment, ensure that the windscreen wiper stalk is in the park position.

**Risk of injury.**



Please note when working close to the engine that it may be hot. The engine cooling fan may also start

at any moment. The  warning light in the engine compartment reminds you of this.

**Risk of injury.**

## TYRE PRESSURE (1/2)

43407



### Label A

To read it, open the driver's door. Tyre pressures should be checked when the tyres are cold.

If the tyre pressures cannot be checked when the tyres are **cold**, increase the pressures from **0.2 to 0.3 bar** (or **3 PSI**). **Never deflate a hot tyre.**



43481

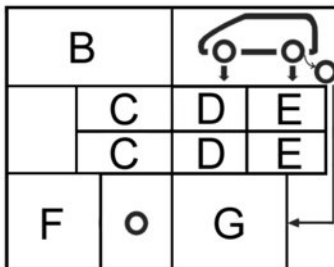

The presence and location of the information on the label depends on the vehicle.

**B:** dimension of the tyres fitted to the vehicle.

**C:** intended driving speed.

**D:** tyre pressures for the front wheels.

**E:** tyre pressures for the rear wheels.

**F:** dimensions of the emergency spare wheel tyre.

**G:** tyre pressure for the emergency spare wheel.

**Tyre safety and the use of chains:** please refer to the "Tyres" paragraph in Section 5 for information on servicing conditions and, depending on the version, the use of chains.



**Special note for fully-loaded vehicles** (maximum authorised all-up weight) **towing a trailer:**

the maximum speed must be limited to **62 mph (100 km/h)** and the tyre pressure increased by **0.2 bar (3 psi)**.

Refer to the information on "Weights" in Section 6.

**Risk of tyre blowouts.**

## TYRE PRESSURES (2/2)

### Vehicle fitted with a tyre pressure loss warning system

If under-inflated (puncture, low pressure, etc.), the  warning light on the instrument panel comes on. See “Tyre pressure loss warning” paragraph in chapter 2.



For your safety, please respect the speed limit.

When they need to be replaced, only tyres of the same make, size, type and profile should be used on a single axle.

**They must: either have a load capacity and speed rating at least equal to those of the original tyres, or conform to those recommended by an authorised dealer.**

Failure to heed these instructions could endanger your safety and affect your vehicle's roadworthiness.

**Risk of loss of control of the vehicle.**

## BATTERY (1/2)

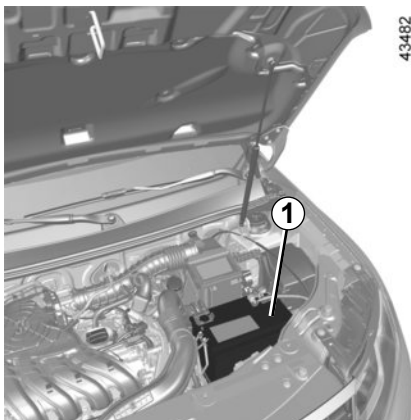

Battery **1** does not require any maintenance. **You should not open it or add any fluid.**



Handle the battery with care as it contains sulphuric acid, which must not come into contact with eyes or skin. If it does, wash the affected area with plenty of cold water and consult a doctor, if necessary.

Ensure that naked flames, red hot objects and sparks do not come into contact with the battery as there is a risk of explosion.



Deactivate the Stop and Start function for any operation performed in the engine compartment.



Before performing any action in the engine compartment, the ignition must be switched off (please see the information on “Starting, stopping the engine” in Section 2).

The charge status of your battery can decrease especially if you use your vehicle:

- for short journeys;
- for driving in town;
- when the temperature drops;
- after extended use of consumers (radio etc.) with the engine switched off.



## BATTERY (2/2)

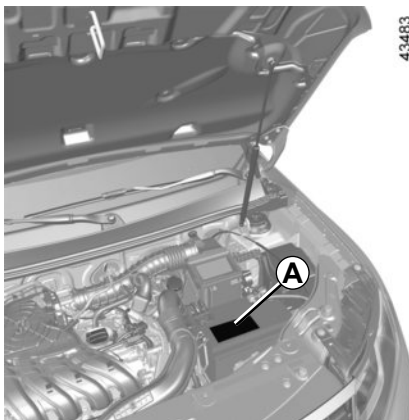

Please note when working close to the engine that it may be hot. The engine cooling fan may also start

at any moment. The  warning light in the engine compartment reminds you of this.

**Risk of injury.**

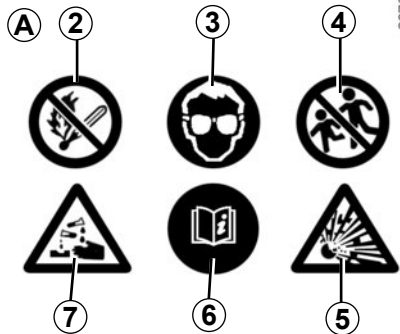

### Label A

Observe the indications on the battery:

- 2 Naked flames and smoking forbidden;
- 3 Wear eye protection;
- 4 Keep away from children;
- 5 Explosive substances;
- 6 Refer to the handbook;
- 7 Corrosive substances.

## Replacing the battery



For your own safety and for the proper operation of the vehicle's electrical equipment (lights, windscreen wipers, ABS, etc.), any intervention on the battery (removal, disconnection, etc.) must categorically be performed by a specialist professional.

### Risk of serious burns from electric shocks.

You must respect the replacement intervals (without exceeding them) as stated in the maintenance document.

The battery is a specific type. Please ensure it is replaced with the same type.

Call an approved Dealer.

## BODYWORK MAINTENANCE (1/3)

A well-maintained vehicle will last longer. It is therefore recommended to maintain the exterior of the vehicle regularly.

Your vehicle has been treated with very effective anti-corrosion products. It is nevertheless subject to various outside influences.

### Corrosive agents in the atmosphere

- atmospheric pollution (built-up and industrial areas);
- saline atmospheres (near the sea, particularly in hot weather);
- seasonal and damp weather conditions (e.g. road salt in winter, water from road cleaners, etc.).

### Minor impacts

#### Abrasive action

Dust and sand in the air, mud, road grit thrown up by other vehicles, etc.

You should take a number of minor precautions in order to safeguard your vehicle against such risks.

### You should

Wash your car frequently, **with the engine off**, with cleaning products recommended by the manufacturer (never use abrasive products). Rinse thoroughly beforehand with a jet:

- spots of tree resin and industrial grime;
  - mud in the wheel arches and underneath the body which forms damp patches;
  - **bird droppings**, which cause a chemical reaction with the paint that **rapidly discolours paintwork and may even cause the paint to peel off**;
- wash the vehicle **immediately** to remove these marks since it is impossible to remove them by polishing;
- salt, particularly in the wheel arches and underneath the body after driving in areas where the roads have been gritted.

Remove any plant matter (resin, leaves, etc.) from the vehicle regularly.

Respect local regulations about washing vehicles (e.g. do not wash your vehicle on a public highway).

Observe the vehicle stopping distances when driving on gravelled surfaces to prevent paint damage.

Repair, or have repaired quickly, areas where the paint has been damaged, to prevent corrosion spreading.

Remember to visit the body shop periodically in order to maintain your anti-corrosion warranty. Refer to the Maintenance Document.

If it is necessary to clean mechanical components, hinges, etc., spray them with products approved by our Technical Department to protect them after they have been cleaned.

We have selected special products to care for your vehicle and you can obtain these from the manufacturer's accessory outlets.

## BODYWORK MAINTENANCE (2/3)

### What you should not do

Wash the vehicle in bright sunlight or freezing temperatures.

Do not scrape off mud or dirt without pre-wetting.

Allow dirt to accumulate on the exterior.

Allow rust to form following minor impacts.

Do not use solvents not approved by our Technical Department to remove stains as this could damage the paintwork.

Do not drive in snow or muddy conditions without washing the vehicle, particularly under the wheel arches and body.



Degrease or clean using high-pressure cleaning equipment or by spraying on products not approved by our Technical Department:

- mechanical components (e.g.: engine compartment);
- the wheels (e.g. braking system components such as brake callipers);
- underbody;
- parts with hinges (e.g.: inside the doors);
- painted plastic external fittings (e.g.: bumpers).

Doing this could give rise to corrosion or operational faults.

## BODYWORK MAINTENANCE (3/3)

### Vehicles with a matte paint finish

This type of paint requires certain precautions.

#### You should do the following

Wash the vehicle by hand using plenty of water, using a soft cloth or a gentle sponge.

#### Do not do the following

Use wax-based products (polishing).

Rub too hard.

Wash the vehicle in a roller-type car wash.

Attach stickers to the paintwork (risk of leaving marks).



Wash the vehicle using a high-pressure cleaning device.

### Cleaning stickers, decorative films, etc.

#### You should do the following

Use a soft cloth or cotton wool.

Moisten it with soapy water, then always wipe clean with a soft cloth or cotton wool.

Finally, carefully dry off with a soft dry cloth.

#### Do not do the following

Use alcohol-based cleaning products.

Use utensils (e.g. scraper).

Rub too hard.



Wash the area using a high-pressure cleaning device.

### Using a roller type car wash

Return the windscreen wiper stalk to the Park position (refer to the information on the "Windscreen washer, wiper" in Section 1). Check the mounting of external accessories, additional lights and mirrors, and ensure that the wiper blades are secured with adhesive tape.

Remove the radio aerial mast if your vehicle is fitted with this equipment.

Remember to remove the tape and refit the antenna after washing.

### Cleaning the headlights, sensors and cameras

Use a soft cloth or cotton wool.

If this does not clean them properly, moisten the cloth with soapy water, then wipe clean with a soft damp cloth or cotton wool.

Finally, carefully dry off with a soft dry cloth.

**Do not use alcohol-based cleaning products or utensils such as scrapers.**

## INTERIOR TRIM MAINTENANCE (1/2)

A well-maintained vehicle will last longer. It is therefore recommended to maintain the interior of the vehicle regularly.

A stain should always be dealt with swiftly.

Whatever type of stain is on the trim, use **cold** (or tepid) **soapy water with natural soap**.

**Detergents (washing-up liquid, powdered products, alcohol-based products) should not be used.**

Use a soft cloth.

Rinse and wipe up excess water.

### Multimedia screen

Maintenance of the screen may depend on the type of multimedia equipment. Please refer to the multimedia instructions for further information.

### Glass instrument panel

(e.g. instrument panel, clock, exterior temperature display etc.)

Use a soft cloth (or cotton wool).

If this does not clean them properly, use a soft cloth (or cotton wool) slightly moistened with soapy water and then wipe clean with another soft damp cloth or cotton wool.

Finally, **carefully** dry off with a soft dry cloth.

**Do not use products containing alcohol and/or spray fluids on the area.**

### Seat belts

They must remain clean.

Use products selected by our Technical Department (approved outlets) or warm, soapy water and a sponge and wipe with a dry cloth.

**Detergents or dyes must not be used under any circumstances.**

### Textiles (seats, door trim, etc)

Vacuum-clean the textiles **regularly**.

#### Liquid stain

Use soapy water.

Dab lightly (never rub) with a soft cloth, rinse and remove the excess.

#### Solid or pasty stain

Carefully remove the excess solid or pasty material **immediately** using a spatula (working from the edges to the centre to avoid spreading the stain).

In the case of a liquid stain, clean as indicated.

#### Special instructions for sweets or chewing gum

Fit an ice cube on the stain to solidify it, then proceed as for a solid stain.

For further recommendations for maintaining the interior, and/or for any unsatisfactory results, please see an authorised dealer.

## INTERIOR TRIM MAINTENANCE (2/2)

### Removal/replacing removable equipment originally fitted in the vehicle

If you need to remove equipment in order to clean the passenger compartment (for example, mats), always ensure that they are correctly refitted and are the right way around (the driver's mat should be fitted on the driver's side, etc.) and fit them with the components supplied with the equipment (for example, the driver mat should always be fixed using the pre-fitted mounting components).

With the vehicle stationary, always ensure that nothing will impede driving (anything obstructing the pedals, heel wedged by the mat etc.).

### You should not:

Position objects such as deodorants, scents etc. near air vents as this could damage your dashboard trim.



Using high-pressure cleaning equipment or sprays inside the passenger compartment:

without careful use, this equipment could impair the correct functioning of the electrical or electronic components in the vehicle, or have other detrimental effects.

# Section 5: Practical advice

Tools . . . . .	5.2
Puncture, Emergency spare wheel . . . . .	5.3
Tyre inflation kit . . . . .	5.6
Wheel trim, Wheels . . . . .	5.10
Changing a wheel . . . . .	5.11
Tyres . . . . .	5.13
Changing bulbs . . . . .	5.17
Front lights . . . . .	5.17
Fog lights . . . . .	5.20
Rear lights . . . . .	5.22
Side indicator lights . . . . .	5.28
Interior lighting . . . . .	5.29
Fuses . . . . .	5.33
Battery: troubleshooting . . . . .	5.37
Radio frequency remote control: batteries . . . . .	5.40
“Hands-free” card: battery . . . . .	5.42
Wipers (replacing blades) . . . . .	5.44
Towing: breakdown . . . . .	5.45
Fitting a radio . . . . .	5.49
Accessories . . . . .	5.50
Operating faults . . . . .	5.51

# TOOLS

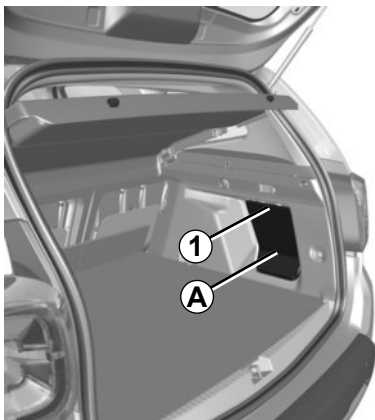

43493

## Accessing the tools

The presence of the various tools depends on the vehicle.

The tools are located in the luggage compartment.

Unclip the flap **A** by placing your hand in the handle **1**. Remove the flap.

After the using the tools, make sure you close the flap **A**. properly.

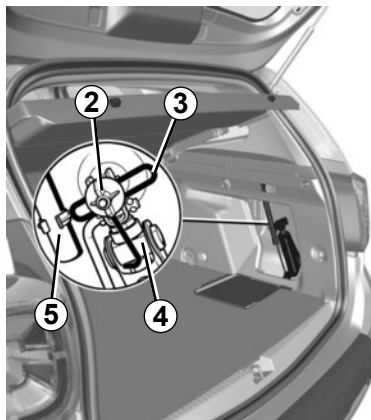

43494

## Jack 4

To use the jack, undo nut **2**. When refitting, fold the jack before placing it in its housing.

Tighten the nut to secure the jack.

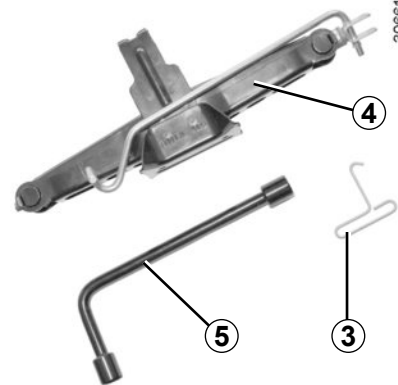

30661

## Wheelbrace 5

This is used to tighten/loosen the wheel bolts and, depending on the vehicle, to access the emergency spare wheel.

## Hubcap tool 3

This tool is used to remove the wheel trims.



Do not leave the tools unsecured inside the vehicle as they may come loose under braking. After use, make sure the tools are correctly positioned in their housings: **risk of injury**.

The jack is designed for wheel changing purposes only. Under no circumstances should it be used for carrying out repairs underneath the vehicle or to gain access to the underside of the vehicle.



# PUNCTURE, EMERGENCY SPARE WHEEL (1/3)

## In case of puncture

Depending on the vehicle, a tyre inflation kit or emergency spare wheel is provided (refer to the following pages).



Do not touch the exhaust, **risk of burns.**



If the vehicle is parked on the hard shoulder, you must warn other road users of your vehicle's presence with a warning triangle or with other devices as per the legislation applying to the country you are in.

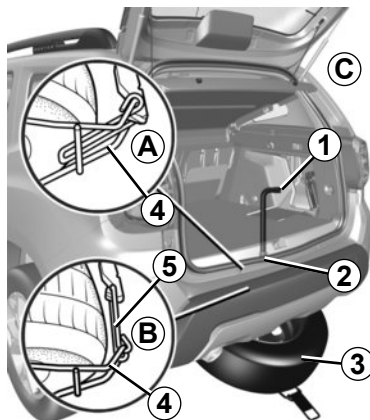

43495

## Emergency spare wheel 4x2 version (2WD)

(depending on the vehicle)

This is located in the cradle **4** under the vehicle **C** or in the boot **D**.

### To take out the spare wheel **3**:

- Open the tailgate;
- undo bolt **2** using wheelbrace **1** (refer to the information on “Tools” in this section);
- detach the holder **4** (example **A**) or depending on the vehicle, detach the holder **4** using the handle **5** (example **B**);

- remove the emergency spare wheel **3**.

### To store the wheel **3** in the cage

- Place the punctured tyre in the sub-frame **4**;
- to return the holder **4** to its initial position, proceed in reverse order and tighten the bolt using the wheelbrace **1** to refit the assembly;
- make sure it is correctly locked.



Do not leave the tools unsecured inside the vehicle as they may come loose under braking. After use, make sure the tools are correctly positioned in their housings: **risk of injury.**

The jack is designed for wheel changing purposes only. Under no circumstances should it be used for carrying out repairs underneath the vehicle or to gain access to the underside of the vehicle.

## PUNCTURE, EMERGENCY SPARE WHEEL (2/3)

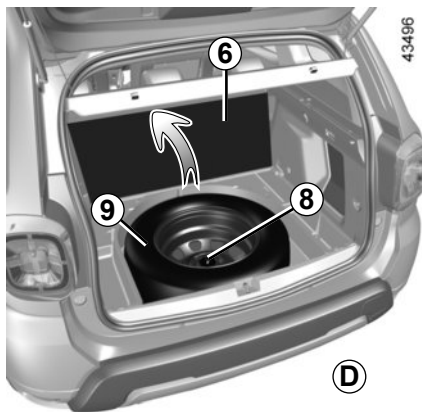

### To take out the spare wheel 9:

- Open the boot lid;
- fold the luggage compartment mat 6;
- depending on the vehicle, remove the part 7;
- unscrew the central mounting 8;
- remove the emergency spare wheel 9.

**Note:** ensure that the emergency spare wheel or punctured wheel and the wheel tray are correctly positioned so that the luggage compartment carpet can be properly fitted.



Do not leave the tools unsecured inside the vehicle as they may come loose under braking. After use, make sure the tools are correctly positioned in their housings: **risk of injury.**

The jack is designed for wheel changing purposes only. Under no circumstances should it be used for carrying out repairs underneath the vehicle or to gain access to the underside of the vehicle.

### Vehicle fitted with a tyre pressure loss warning system

If under-inflated (puncture, low pressure etc.), the warning light  lights up on the instrument panel; please refer to “Tyre pressure monitoring system” in Section 2.

## PUNCTURE, EMERGENCY SPARE WHEEL (3/3)

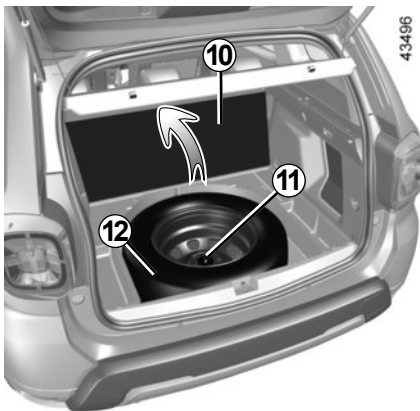

### Emergency spare wheel 4x4 version (4WD)

This is located in the luggage compartment.

To access it:

- Open the boot lid;
- fold the luggage compartment mat **10**;
- unscrew the central mounting **11**;
- remove the emergency spare wheel **12**.

**Note:** ensure that the emergency spare wheel or punctured wheel and the wheel tray are correctly positioned so that the luggage compartment carpet can be properly fitted.



If the emergency spare wheel has been stored for several years, have it checked by your Dealer to ensure that it is safe to use.

### Vehicles fitted with an emergency spare wheel which is different to the other four wheels:

- Never fit more than one emergency spare wheel to the same vehicle.
- Replace the emergency spare wheel as soon as possible with a wheel identical to the original one.
- When this is fitted to the vehicle, which must only be a temporary measure, the driving speed must not exceed the speed indicated on the label on the wheel.
- Fitting an emergency spare wheel may alter the way the vehicle usually runs. Avoid sudden acceleration or deceleration and reduce your speed when cornering.
- If you need to use snow chains, fit the emergency spare wheel to the rear axle and check the tyre pressure.

# TYRE INFLATION KIT (1/4)

32788



The kit repairs tyres when tread **A** has been damaged by objects smaller than 4 mm. It cannot repair all types of puncture, such as cuts larger than 4 mm, or cuts in tyre sidewall **B**.

Ensure also that the wheel rim is in good condition.

Do not pull out the foreign body causing the puncture if it is still in the tyre.



Do not attempt to use the inflation kit if the tyre has been damaged as a result of driving with a puncture.

You should therefore carefully check the condition of the tyre sidewalls before any operation.

Driving with underinflated, flat or punctured tyres can be dangerous and may make the tyre impossible to repair.

### **This repair is temporary**

A tyre which has been punctured should always be inspected (and repaired, where possible) as soon as possible by a specialist.

When taking a tyre which has been repaired using this kit to be replaced, you must inform the specialist.

When driving, vibration may be felt due to the presence of the repair product injected into the tyre.



The kit is only approved for inflating the tyres of the vehicle initially fitted with the kit. It must never be used to inflate the tyres of another vehicle, or any other inflatable object (rubber ring, rubber boat, etc.).

Avoid spillage on skin when handling the repair product bottle. If droplets do leak out, rinse them off with plenty of water.

Keep the repair kit away from children.

Do not dispose of the empty bottle in the countryside. Return it to your approved dealer or to a recycling organisation.

The bottle has a limited service life which is indicated on its label. Check the expiry date.

Contact an approved dealer to replace the inflation tube and repair product bottle.

## TYRE INFLATION KIT (2/4)

35749

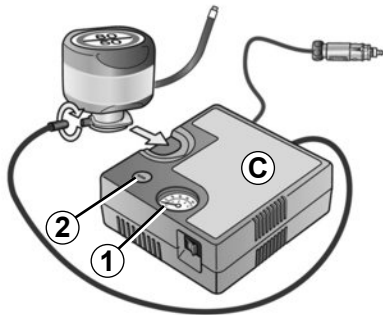

In the event of a puncture, use the kit **C** located in the luggage compartment in the 4x2 version or in the emergency spare wheel tray under the luggage compartment carpet in the 4x4 version.

The image may not be contractual with the kit supplied with the vehicle.

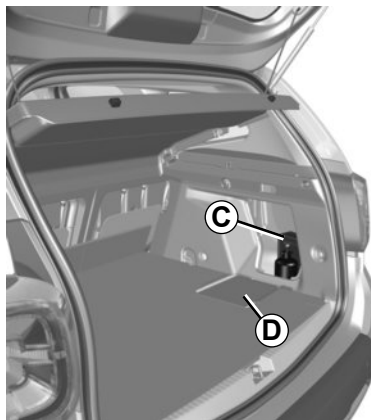

On 4x2 versions, unclip flap **D**.

43516

### Vehicle fitted with a tyre pressure loss warning system

If under-inflated (puncture, low pressure, etc.), the warning light  lights up on the instrument panel. See "Tyre pressure loss warning" in Section 2.



Before using this kit, park the vehicle at a sufficient distance from traffic, switch on the hazard warning lights, apply the handbrake, ask all passengers to leave the vehicle and keep them away from traffic.



If the vehicle is parked on the hard shoulder, you must warn other road users of your vehicle's presence with a warning triangle or with other devices as per the legislation applying to the country you are in.

## TYRE INFLATION KIT (3/4)

### Engine running, handbrake applied,

- Disconnect any accessories previously connected to the vehicle's accessories sockets;
- **refer to the information on the inflation kit compressor** located in the boot of the vehicle and follow the instructions;
- inflate the tyre to the recommended pressure (please refer to the information in the "Tyre pressures" section);
- after a maximum of **15** minutes, stop inflating and read the pressure (on pressure gauge **1**);

**Note:** while the bottle is emptying (approximately 30 seconds), the pressure gauge **1** will indicate briefly a pressure of up to **6** bars, then the pressure drops.

- Adjust the pressure: to increase it, continue inflation with the kit. To reduce it, press the button **2**.

**If a minimum pressure of 1.8 bar cannot be obtained after 15 minutes, repair is impossible. Do not drive the vehicle. Consult an approved dealer.**



Nothing should be placed around the driver's feet as such objects may slide under the pedals during sudden braking manoeuvres and obstruct their use.



Please be aware that a poorly tightened or missing valve cap can make the tyres less airtight and lead to pressure loss. Always use valve caps identical to the original ones and ensure they are tightly screwed on.

## TYRE INFLATION KIT (4/4)

35749

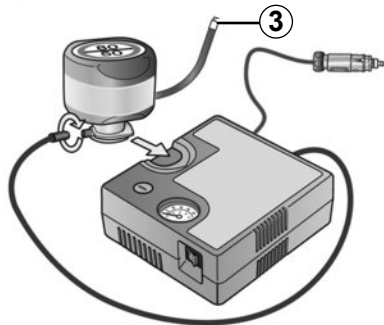

Once the tyre is correctly inflated, remove the kit: slowly unscrew the inflation end piece of the container **3** to prevent any product spatter and store the container in plastic packaging to prevent product leaks.

- Affix the driving recommendation label (located under the container) to the dashboard where the driver can see it.
- Put the kit away.

- At the end of this initial inflation operation, air will still escape from the tyre. You must drive a short distance in order to seal the hole.
- Start immediately and drive at a speed of 12 to 37 mph (20 to 60 km/h) in order to distribute the product evenly in the tyre; after driving a distance of 2 miles (3 km), stop and check the pressure.
- If the pressure is higher than 1.3 bar but lower than the recommended pressure (refer to the label affixed to the edge of the driver's door), adjust it. Otherwise, contact an approved dealer: the tyre cannot be repaired.

### Precautions when using the kit

The kit should not be operated for more than 15 consecutive minutes.

The container must be replaced after the first use even if liquid remains inside.



Following repair with the kit, do not travel further than 120 miles (200 km). In addition, reduce your speed and under no circumstances exceed 48 mph (80 km/h). The sticker, which you must affix in a prominent position on the dashboard, reminds you of this.

Depending on the country or local legislation, a tyre repaired with the inflation kit may need to be replaced.

## WHEEL TRIM, WHEELS

43497



### Central wheel trim with visible wheel bolts

(Wheel trim 1)

The bolts are directly accessible.

30572

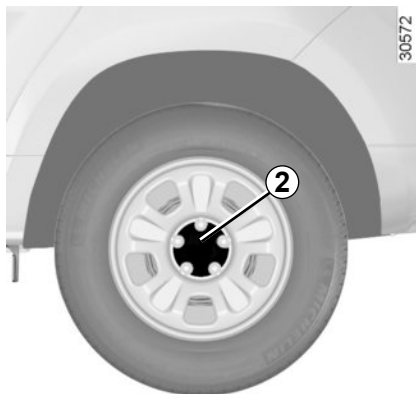

### Central wheel trim with visible wheel bolts

(Wheel trim 2)

Remove it using the hubcap tool, by inserting the hook near a wheel bolt (refer to the information on "Tools").

To put it back, position hooks 4 in relation to bolts 3.

Push in the wheel trim's retaining hooks.

30677

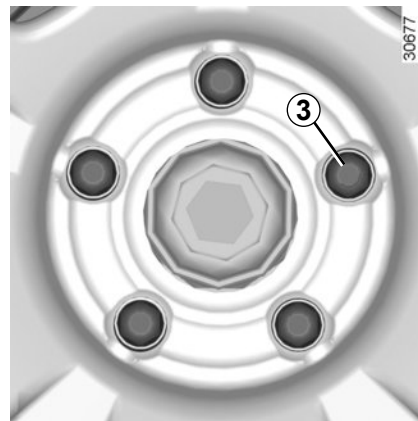

30676

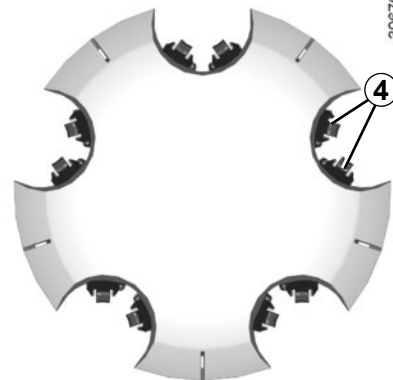



## CHANGING A WHEEL (1/2)

43611

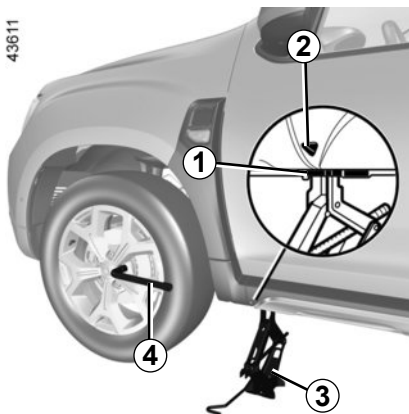

### Vehicles equipped with a jack and wheelbrace

If necessary, remove the wheel trim, refer to the information on “Wheel trims - Wheels” in this Section. Undo the wheel bolts using wheelbrace **4**. Fit it so that you press downwards rather than pulling upwards.



To prevent any risk of injury or damage to the vehicle, only crank the jack until the wheel you are replacing is a maximum of 3 centimetres off the ground.

Place the jack **3** horizontally; the jack head **must** be lined up with the sill **1** closest to the wheel concerned, as shown by arrow **2**.

Start cranking the jack up by hand to align the base plate (which should be pushed slightly under the vehicle). Turn the wheelbrace until the wheel lifts off the ground.

Remove the bolts.

Take off the wheel.

Fit the emergency spare wheel on the central hub and turn it to align the mounting holes in the wheel and the hub.



If you have a puncture, replace the wheel as soon as possible.

A tyre which has been punctured should always be inspected (and repaired, where possible) by a specialist.



Switch on the hazard warning lights.

Keep the vehicle away from traffic and on a level surface where it will not slip.

Apply the parking brake and engage a gear (first or reverse, or P for automatic transmissions).

Ask the passengers to leave the vehicle and to keep away from traffic.



If the vehicle is parked on the hard shoulder, you must warn other road users of your vehicle's presence with a warning triangle or with other devices as per the legislation applying to the country you are in.

## CHANGING A WHEEL (2/2)

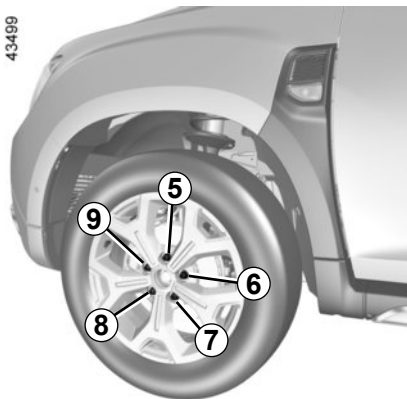

Tighten the bolts, checking that the wheel is correctly positioned on its hub and lower the jack.

With the wheels on the ground, tighten the bolts firmly, starting on side **5**, then **7**, **9**, **6** and ending with **8**. Check the tightness and the tyre pressure on the emergency spare wheel as soon as possible.

### Vehicle fitted with a tyre pressure loss warning system

If under-inflated (puncture, low pressure, etc.), the warning light  lights up on the instrument panel. See “Tyre pressure loss warning” in Section 2.

**Note:** ensure that the emergency spare wheel or punctured wheel and the wheel tray are correctly positioned so that the luggage compartment carpet can be properly fitted.



Do not leave the tools unsecured inside the vehicle as they may come loose under braking. After use, make sure the tools are correctly positioned in their housings: **risk of injury**.

The jack is designed for wheel changing purposes only. Under no circumstances should it be used for carrying out repairs underneath the vehicle or to gain access to the underside of the vehicle.

# TYRES (1/4)

## Tyre and wheel safety

The tyres are the only contact between the vehicle and the road, so it is essential to keep them in good condition. You must make sure that your tyres conform to local road traffic regulations.



For your safety, please respect the speed limit.

When they need to be replaced, only tyres of the same make, size, type and profile should be used on a single axle.

**They must: either have a load capacity and a speed capacity at least equal to the original tyres, or correspond to those recommended by your authorised dealer.**

Failure to heed these instructions could endanger your safety and affect your vehicle's roadworthiness.

**Risk of loss of control of the vehicle.**



## Maintaining the tyres

The tyres must be in good condition and the tread form must have sufficient depth; tyres approved by our Technical Department have wear warning strips **1** which are **indicators moulded into the tread at several points.**

When the tyre tread has been worn to the level of the warning strips, **they become visible 2**: it is **then** necessary to replace your tyres because the tread rubber is now only **1.6 mm deep at most, resulting in poor road holding on wet roads.**

An overloaded vehicle, long journeys by motorway, particularly in very hot weather, or continual driving on poorly surfaced minor roads will lead to more rapid tyre wear and affect safety.



Incidents which occur when driving, such as striking the kerb, may damage the tyres and wheel rims, and could also lead to misalignment of the front or rear axle geometry. If such incidents occur, have the condition of these parts checked by an approved dealer.

## TYRES (2/4)

### Tyre pressures

Adhere to the tyre pressures (including the emergency spare wheel). The tyre pressures should be checked at least once a month and additionally before any long journey (refer to the label affixed to the edge of the driver's door).



#### **Incorrect tyre pressures**

lead to abnormal tyre wear and unusually hot running.

These are factors which may seriously affect safety and lead to:

- poor road holding;
- risk of blowouts or throwing a tread.

The tyre pressure depends on the load and speed of use; adjust the pressures according to the conditions of use (refer to the information on "Tyre pressures" in Section 4).

Pressures should be checked when the tyres are cold; ignore higher pressures which may be reached in hot weather or following a fast journey.

If tyre pressures cannot be checked when the tyres are **cold**, assume an increase of **0.2** to **0.3** bar.

**Never deflate a hot tyre.**

#### **Special note**

Depending on the vehicle, there may be an adapter which needs to be positioned on the valve before air is added.

Your vehicle is equipped with large wheels. These are more sensitive to imbalance. If you experience vibration while driving, contact an approved dealer.



Please be aware that a poorly tightened or missing valve cap can make the tyres less airtight and may lead to pressure loss.

Always use valve caps which are identical to the originals.

## TYRES (3/4)

### Vehicle fitted with a tyre pressure loss warning system

If underinflated (puncture, low pressure, etc.), the warning light  on the instrument panel comes on, see “Tyre pressure loss warning system” in Section 2.

### Emergency spare wheel

Refer to the information on “Puncture” and “Changing a wheel” in Section 5.



#### Changing a wheel

As the tyre pressure loss warning system may take several minutes to correctly determine the positions of the wheels and the pressure values after driving, check the tyre pressures following any operation.

## Fitting new tyres



For safety reasons, this operation must be carried out by a specialist.

Fitting different tyres may change your vehicle as follows:

- it may mean that your vehicle no longer conforms to current regulations;
- It may change the way it handles when cornering;
- It may cause the steering to be heavy;
- it may affect the use of snow chains.

## Changing wheels around

### 4x4 version

We recommend that you swap the wheels regularly in order to ensure that the tyres wear evenly.

Swap the wheels as shown in the above diagram. Refer to your vehicle’s maintenance document for the intervals.

### 4x2 version

This practice is not recommended.

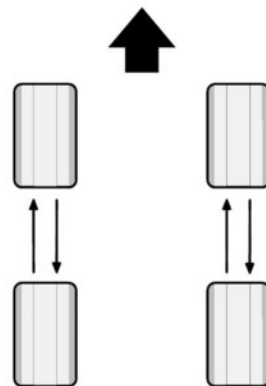

## TYRES (4/4)

### Use in winter

#### Chains

2-wheel drive version (2WD)

**Snow chains must be fitted to the front wheels.**

4-wheel drive version (4WD)

**Snow chains may be fitted to only the front wheels, or to all four wheels.**

**Chains cannot be fitted** to tyres which are larger than those originally fitted to the vehicle.



Snow chains may only be fitted to tyres of the same size as those originally fitted to **your vehicle**.

#### Snow or Winter tyres

We would recommend that these be fitted to all **four wheels** to ensure that your vehicle retains maximum adhesion.

**Warning:** These tyres sometimes have a specific direction of rotation and a maximum speed index which may be lower than the maximum speed of your vehicle.

#### Studded tyres

This type of equipment may only be used for a limited period and as laid down by local legislation.

It is necessary to observe the speed specified by current legislation.

These tyres must be fitted at least to both wheels on the front axle or, depending on the country, to all wheels on the vehicle.

In all cases, we would recommend that you contact your approved dealer who will be able to advise you on the choice of equipment which is most suitable for your vehicle.

## FRONT HEADLIGHTS: replacing the bulbs (1/3)

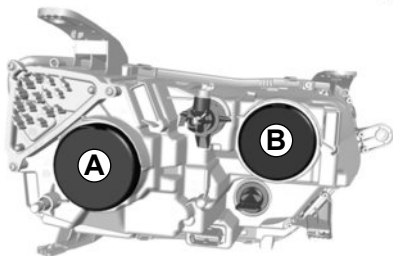

### Dipped beams

Remove cover **A**.

Tilt bulb holder **3** to release it and then replace the bulb.

**Type of bulb: H7.**

After replacing the bulb, please ensure that the lights are adjusted by a professional.



The bulbs are under pressure and can break when replaced.

**Risk of injury.**

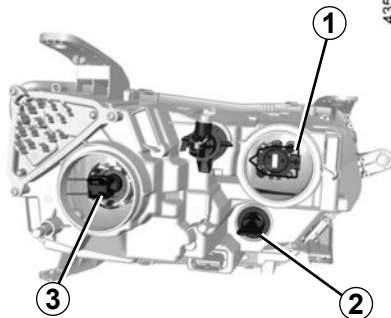

**Before replacing the bulb,** for the dipped beam headlight or the main beam headlight, make a careful note of its original position in its housing. After changing it, check that the replacement bulb is in exactly the same position in the housing. Clip the cover in place.

### Main beam headlight

Remove cover **B**.

Tilt bulb holder **1** to release it and then replace the bulb.

**Type of bulb: H1.**

**Do not touch the bulb glass. Hold it by its base.**

It is **essential** to use anti-U.V. 55W bulbs so as not to damage the plastic on the headlights.



Please note when working close to the engine that it may be hot. The engine cooling fan may also start

at any moment. The  warning light in the engine compartment reminds you of this.

**Risk of injury.**

## FRONT HEADLIGHTS: replacing the bulbs (2/3)

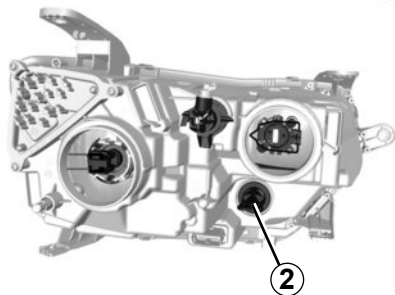

### Direction indicator lights

Turn the bulb holder 2 a quarter of a turn and take out the bulb.

**Type of bulb: PY21W.**



### Daytime running light, front LED side light 4

Please see an authorised dealer.

To comply with current legislation, or as a precaution, you can obtain an emergency kit from your approved dealer containing a set of spare bulbs and fuses.



Before performing any action in the engine compartment, the ignition must be switched off (please see the information on “Starting, stopping the engine” in Section 2).



Any operation on (or modification to) the electrical system must be performed by an approved dealer since an incorrect connection might damage the electrical equipment (harness, components and in particular the alternator). In addition, your Dealer has all the parts required for fitting these units.



## FRONT HEADLIGHTS: replacing the bulbs (3/3)

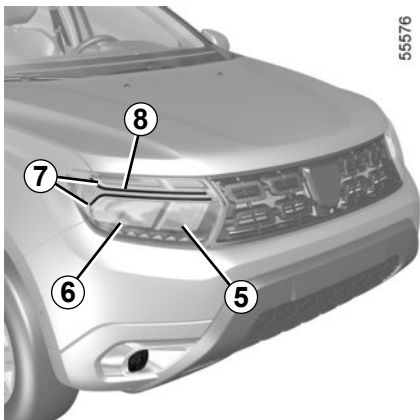

### Main beam headlight 5

(depending on the vehicle)

Remove cover **C**.

Unclip the connector **9**, remove the assembly from its housing and take out the bulb.

**Type of bulb:** H1.

**Before replacing the bulb**, make a careful note of its position in its housing. After changing it, check that the replacement bulb is in exactly the same position in the housing. Clip the cover in place.

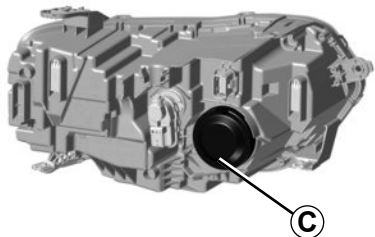

### LED dipped beam headlight 6

(depending on the vehicle)

Please see an authorised dealer.

### LED daytime running light/ side light 7

(depending on the vehicle)

Please see an authorised dealer.

### LED direction indicator light 8

(depending on the vehicle)

Please see an authorised dealer.

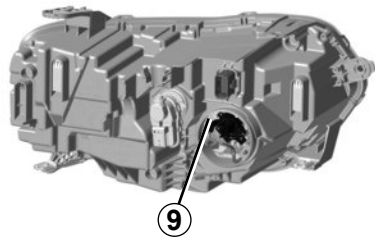

Please note when working close to the engine that it may be hot. The engine cooling fan may also start

at any moment. The  warning light in the engine compartment reminds you of this.

**Risk of injury.**

## FOG LIGHTS: changing bulbs (1/2)

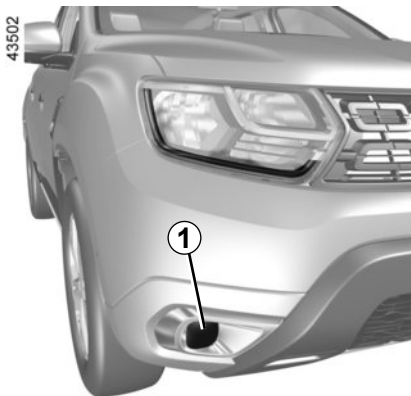

### Front fog lights 1

- Access the bulb holder by releasing flap 2;
- turn the bulb holder a quarter turn;
- remove the bulb.

#### Type of bulb: H16

or H11 (depending on the vehicle).



The bulbs are under pressure and can break when replaced.

#### Risk of injury.

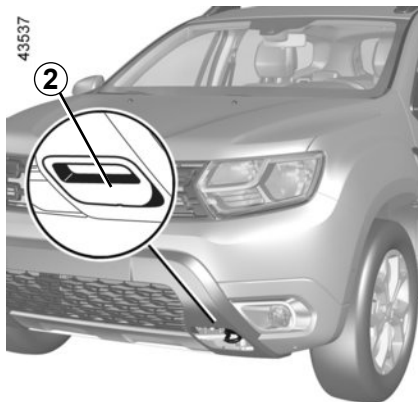

### Refitting

To refit, proceed in the reverse order, taking care not to damage the wiring.

Once the bulb has been replaced, check that it is properly secured.

However, **we would advise you to have these bulbs replaced by an Approved Dealer.**

To comply with local legislation, or as a precaution, you can obtain an emergency kit containing a set of spare bulbs and fuses from an approved Dealer.



Please note when working close to the engine that it may be hot. The engine cooling fan may also start

at any moment. The  warning light in the engine compartment reminds you of this.

#### Risk of injury.

## FOG LIGHTS: changing bulbs (2/2)



### Rear fog light 3

(depending on vehicle)

Access the bulb holder located under the rear bumper, then unscrew it by turning towards the centre of the vehicle and remove the bulb.

**Bulb type: P21W.**



Do not touch the exhaust.  
**Risk of burns.**

### Refitting

To refit, proceed in the reverse order, taking care not to damage the wiring.

Once the bulb has been replaced, check that it is properly secured.

However, because of their reduced accessibility, **we advise you to have your bulbs replaced by an approved Dealer.**



The bulbs are under pressure and can break when replaced.

**Risk of injury.**



Any operation on (or modification to) the electrical system must be performed by an approved Dealer since an incorrect connection might damage the electrical equipment (harness, components and in particular the alternator). In addition, your Dealer has all the parts required for fitting these units.

## REAR LIGHTS: replacing the bulbs (1/6)

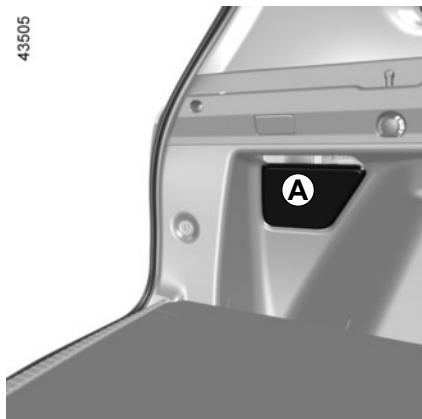

### Direction indicator lights / brake and side lights

Open the luggage compartment lid and remove cover **A**. Unscrew the nuts **1** and release the clips **2**, then pull out the light unit **3**.

Release the connector **4** and unlock the clips **5** to remove the bulb holder **6**.

To comply with current legislation, or as a precaution, you can obtain an emergency kit from your approved dealer containing a set of spare bulbs and fuses.

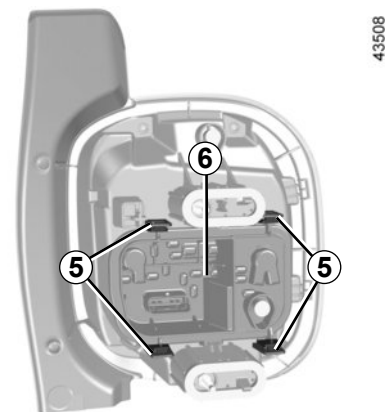
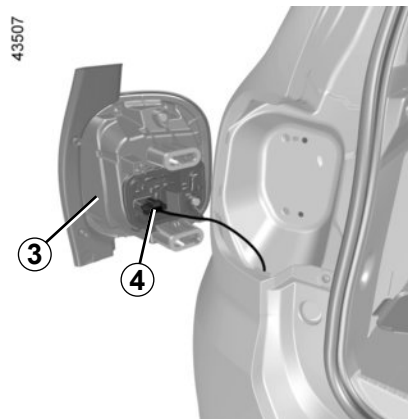
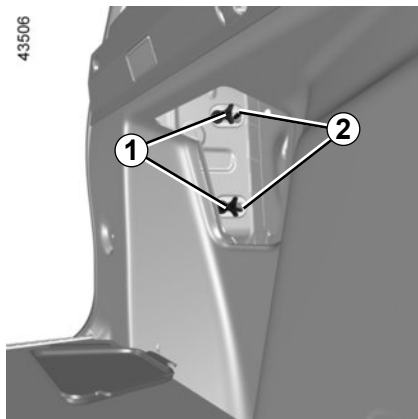

The bulbs are under pressure and can break when replaced.

**Risk of injury.**

## REAR LIGHTS: replacing the bulbs (2/6)

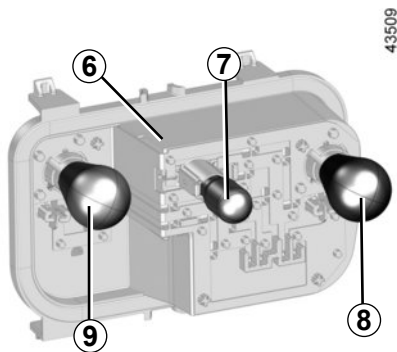

### 7 Direction indicator lights

Type of bulb: **WY16W**.

### 8 Side light

Pear-shaped, bayonet type **P21/5W** bulb with two filaments.

### 9 Side light and brake light

Pear-shaped, bayonet type **P21/5W** bulb with two filaments.

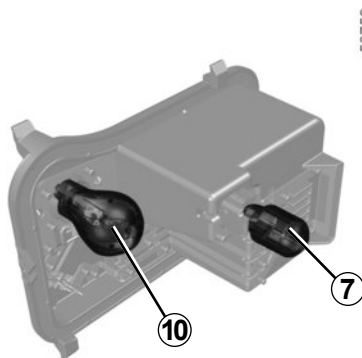

### 10 Brake light (depending on the vehicle)

Type of bulb: **P21W**.



Do not touch the exhaust.

**Risk of burns.**

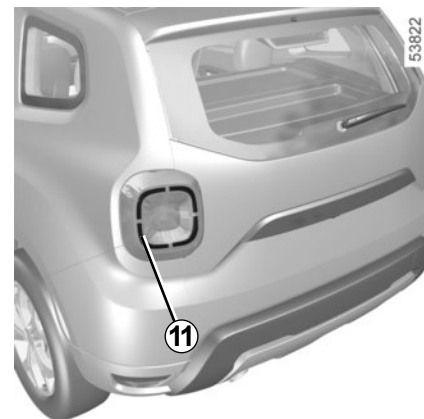

### LED side light 11

(depending on the vehicle)

Consult an approved dealer.

## REAR LIGHTS: replacing the bulbs (3/6)

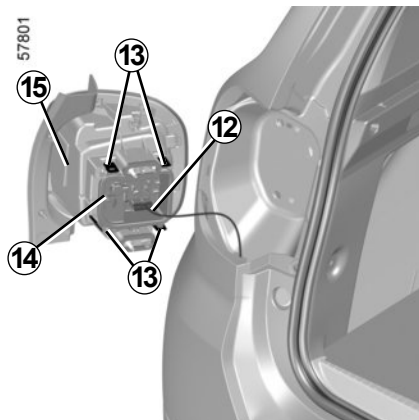

### Direction indicator lights/ brake and side lights

(depending on the vehicle)

Open the luggage compartment lid and remove cover **A**. Unscrew the nuts **1** and release the clips **2**, then pull out the light unit **15**.

Release the connector **12** and unlock the clips **13** to remove the bulb holder **14**. Release the position connector **16**.

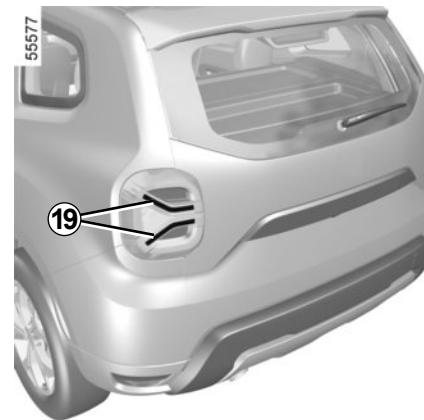
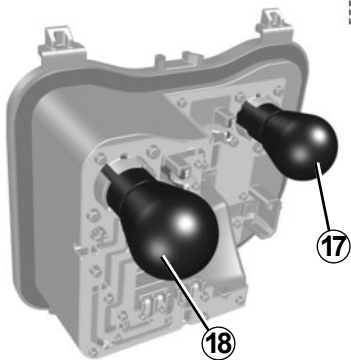
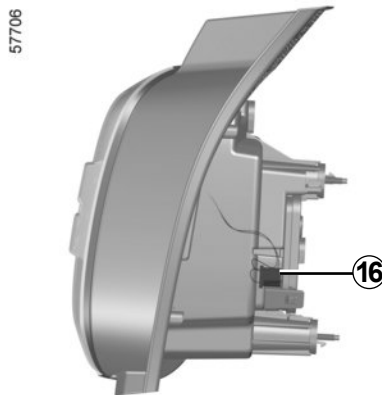

**Brake light 17**

**Bulb type: P21W.**

**Direction indicators 18**

**Bulb type: PY21W.**

**LED side light 19**

Consult an approved dealer.



The bulbs are under pressure and can break when replaced.

**Risk of injury.**

## REAR LIGHTS: replacing the bulbs (4/6)

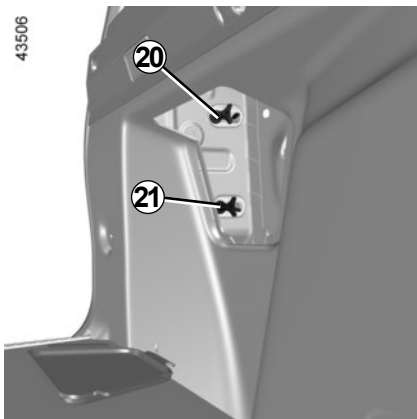

### Refitting

To re-fit, proceed in the reverse order taking care not to damage the wiring, tighten nut **20** first, then nut **21**.



### Reversing light 22 (depending on vehicle)

Access the bulb holder located under the rear bumper, then unscrew it by turning towards the centre of the vehicle and remove the bulb.

**Type of bulb: P21W.**

### Refitting

To refit, proceed in the reverse order, taking care not to damage the wiring. Once the bulb has been replaced, check that it is properly secured.

However, because of their reduced accessibility, **we advise you to have your bulbs replaced by an Approved Dealer.**

## REAR LIGHTS: replacing the bulbs (5/6)



43510

### High-level LED brake light 23

Consult an approved dealer.



55579

### LED number plate light 24

(depending on vehicle)

Consult an approved dealer



The bulbs are under pressure and can break when replaced.

**Risk of injury.**



## REAR LIGHTS: replacing the bulbs (6/6)

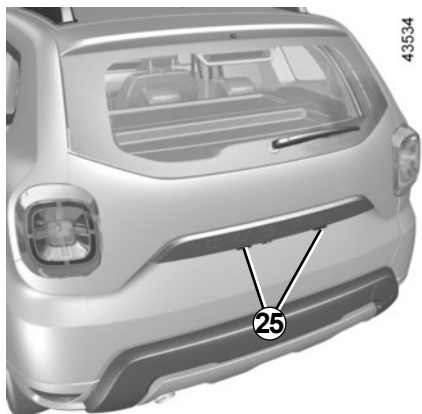

### Number plate light 25

Unclip light **25** by pressing tab **26** using a flat-blade screwdriver or similar.

Unclip lens **27** and take out bulb **28**.

### Bulb type 28: W5W.

However, because of their reduced accessibility, **we advise you to have your bulbs replaced by an Approved Dealer.**

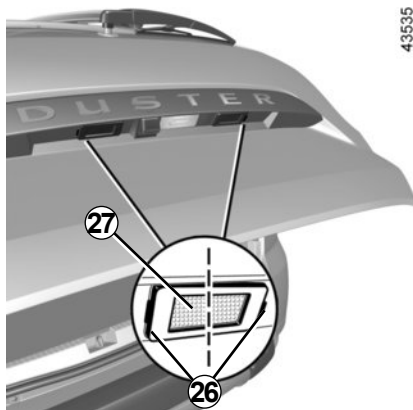

The bulbs are under pressure and can break when replaced.

**Risk of injury.**

## INDICATOR LIGHTS: changing bulbs

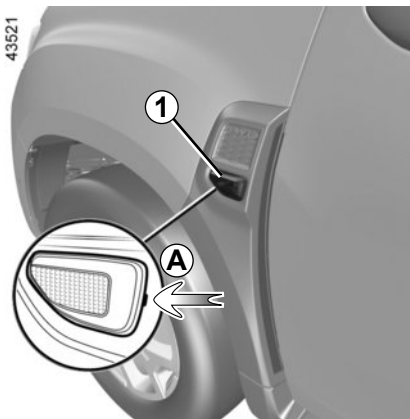

Unclip the indicator light **1** using a flat-blade screwdriver or similar positioned at **A** to flip the indicator light towards the outside of the vehicle.

Turn bulb holder **2** a quarter of a turn (movement **B**) and take out bulb **3** (movement **C**).

**Bulb type: WY5W** or, depending on the vehicle, **W5W**.

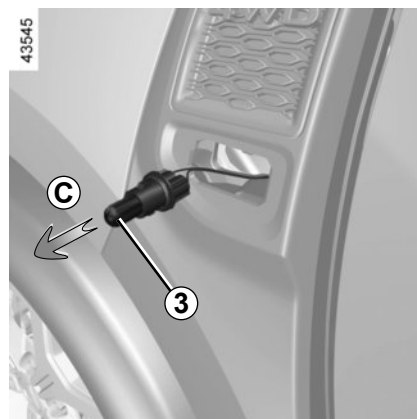
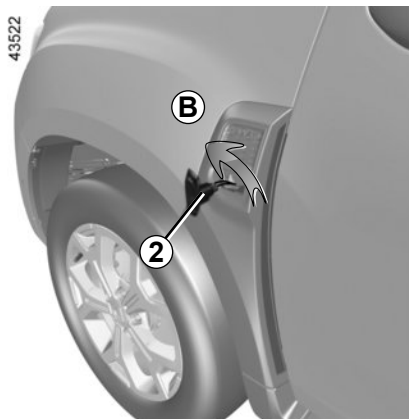

The bulbs are under pressure and can break when replaced.

**Risk of injury.**

## INTERIOR LIGHTS: changing bulbs (1/4)

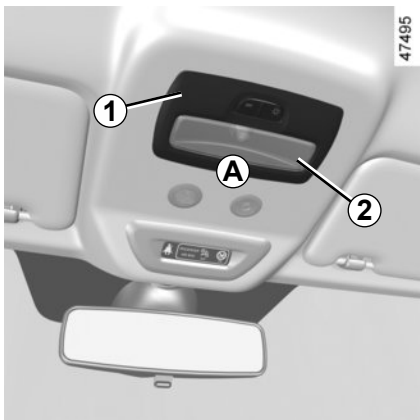

### Front ceiling light 1

- Unclip the lens 2 using a flat screwdriver-type tool, positioned in A;
- unclip and release the bulb holder 3 using the tabs 4;
- remove the bulb concerned.

Type of bulb 5: W5W.

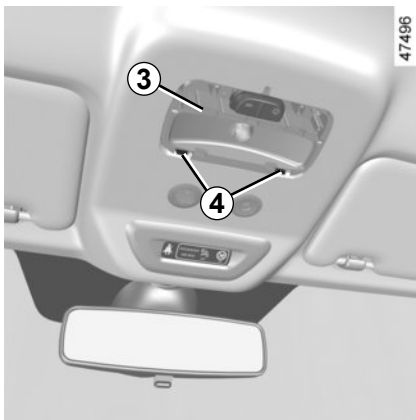

### Refitting

- Clip the lens 2 on to the bulb holder 3;
- clip in the interior lights 1 until the unit clicks;
- ensure that the interior lights are properly positioned and locked into place.



The bulbs are under pressure and can break when replaced.

**Risk of injury.**

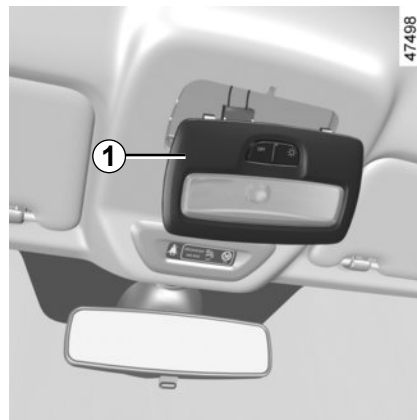
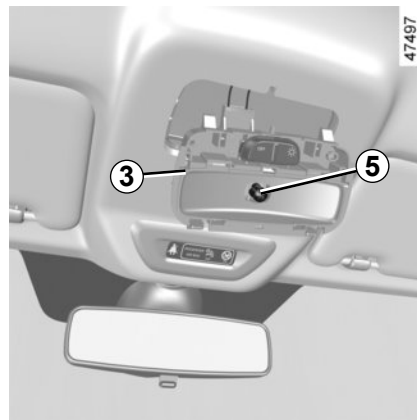

## INTERIOR LIGHTS: changing bulbs (2/4)

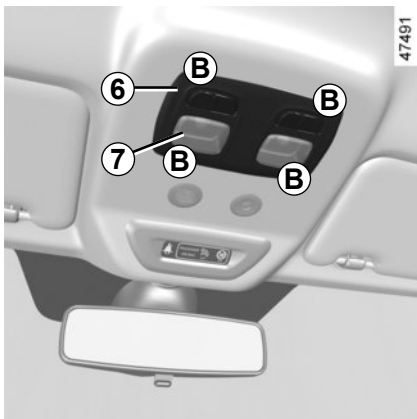

### Front map reading lights 6

(depending on the vehicle)

- Unclip the lens 7 using a flat screw-driver-type tool, positioned in B;
- unclip and release the bulb holder 8 using the tabs 9;
- remove the bulb concerned.

Type of bulb 10: W5W.

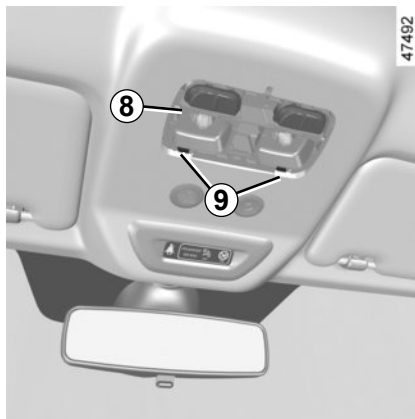

### Refitting

- Clip the lens 7 on to the bulb holder 8;
- clip in the reading spots block 6 until the unit clicks;
- make sure that the reading spots block is correctly positioned and locked into place.

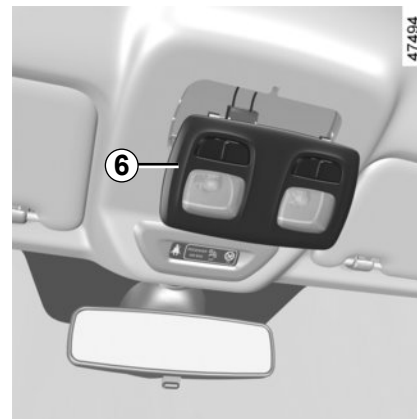
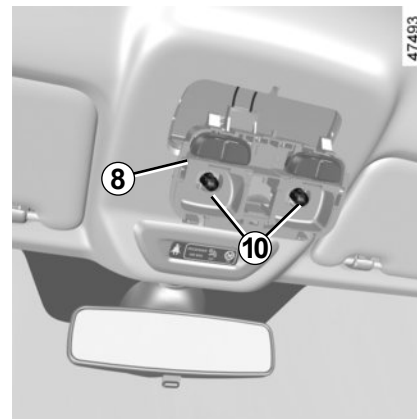

## INTERIOR LIGHTS: changing bulbs (3/4)

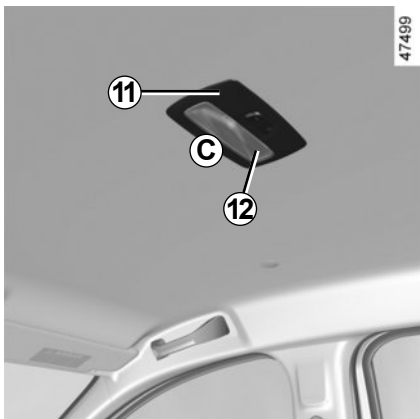

### Rear reading spot 11

(depending on the vehicle)

- Unclip the lens 12 using a flat screwdriver-type tool, positioned in C;
- unclip and release the bulb holder 13 using the tabs 14;
- remove the bulb concerned.

**Type of bulb 15: W5W.**

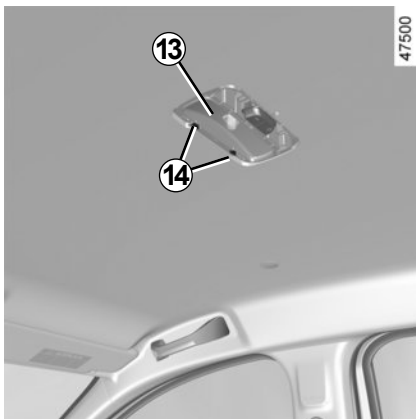

### Refitting

- Clip the lens 12 on to the bulb holder 13;
- clip in the reading spots block 11 until the unit clicks;
- make sure that the reading spots block is correctly positioned and locked into place.



The bulbs are under pressure and can break when replaced.

**Risk of injury.**

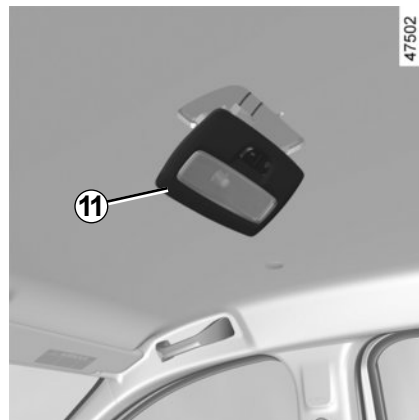
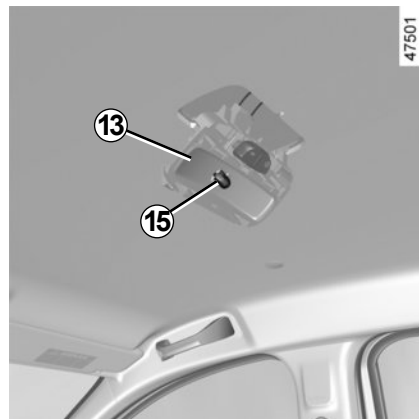

## INTERIOR LIGHTS: changing bulbs (4/4)

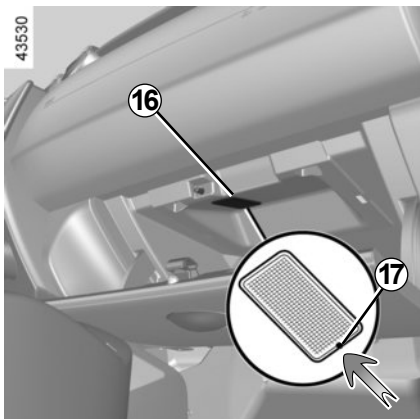

### Glove box light **16** (depending on the vehicle)

Unclip the light **16** by pressing the tab **17** with a flat-blade screwdriver or similar to move the light towards the inside of the unit.

Disconnect the light.

**Type of bulb: W5W.**

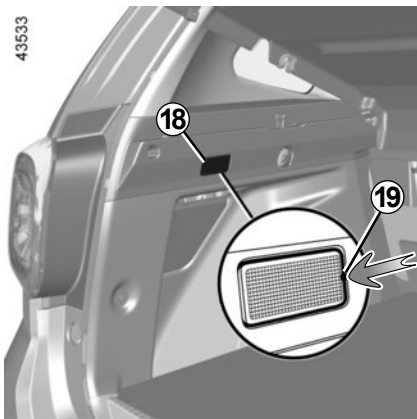

### Luggage compartment light **18**

Unclip light **18** using a flat-blade screwdriver or similar, by pressing on tab **19** to move the light towards the inside of the luggage compartment.

Disconnect the light.

**Type of bulb: W5W.**

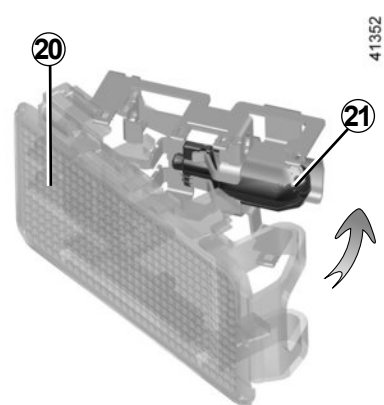

Release the lens **20** and access bulb **21**.

**Type of bulb 21: W5W.**



The bulbs are under pressure and can break when replaced.

**Risk of injury.**

## FUSES (1/4)

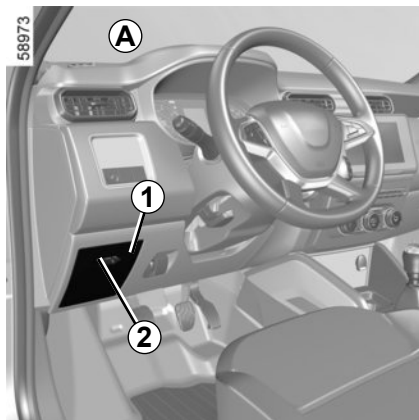

### Fuse box

If any electrical component does not work, check the condition of the fuses.

Unclip the **1** flap using the **2** notch or, depending on the vehicle, unclip the **3** flap using the **4** notch.

Depending on the vehicle, to identify the fuses, refer to the fuse allocation label located at the back of the **1** or **3** flap and shown on the following pages.

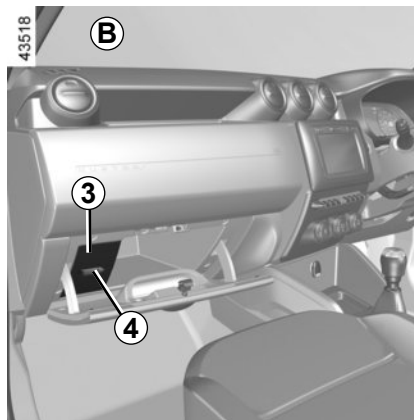

### Tweezers 5

Remove the fuse using the tweezers **5** located on the back of flap **1** or **3**.

To remove the fuse from the tweezers, slide the fuse to the side.

It is not advisable to use the free fuse locations.

To comply with current legislation, or as a precaution, you can obtain an emergency kit from your approved dealer containing a set of spare bulbs and fuses.

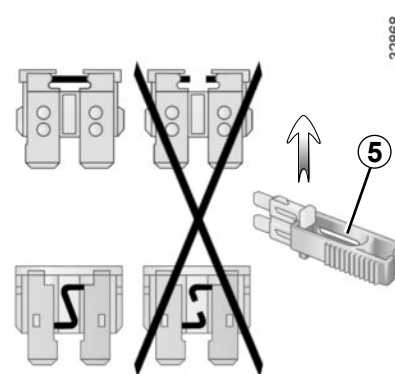











Check the fuse in question and **replace it**, if necessary, **with a fuse of the same rating**.











If a fuse is fitted where the rating is too high, it may cause the electrical circuit to overheat (risk of fire) in the event of an item of equipment using an excessive amount of current.

## FUSES (2/4)

### Allocation of fuses

(the presence and location of fuses depends on the vehicle equipment level)

Symbol	Allocation
	Horn, central alarm unit
	Front window winder, electric front windows
	Rear electric windows
	Rear screen wash/wipe pump
	Interior lights, boot light, glovebox light
	Energy management unit, electrical locking, brake lights, main beam headlights, dipped beam headlights, daytime running lights, fog lights, side lights
	Multimedia, heated seat
	4-wheel drive (4WD) transmission, automatic gearbox
	Direction indicator lights
	LPG











Symbol	Allocation
	Automatic door locking
	Left-hand main beam headlight, right-hand dipped beam headlight, left-hand daytime running lights, rear fog lights, side lights
	Towbar socket
	Rear accessories socket
	ABS - ESC, brake switch, clutch switch, engine immobiliser
	Injection, instrument panel, passenger compartment unit
	Hands-free access unit
	Airbag
	Light sensor, child safety
	Starter



## FUSES (3/4)

### Allocation of fuses

(the presence and location of fuses depends on the vehicle equipment level)

Symbol	Allocation
	Front windscreen wiper
	Passenger compartment ventilation
	Power-assisted steering
	Instrument panel
	Heated rear windscreen, seatbelt warning, park assist, additional passenger compartment heating, cruise control/speed limiter
	Radio, air conditioning control panel, passenger compartment ventilation, rear accessories socket
	Cigarette lighter
	Defrosting rear view mirror
	Rear view electric mirrors control
 	Right-hand main beam headlights, left-hand dipped beam headlights, right-hand daytime running light, front fog lights, side lights

Use the fuse allocation label in the storage compartment to identify the fuses.

Passenger compartment **A**: the fuse allocation label is on the rear side of the flap **1**.

Passenger compartment **B**: the fuse allocation label is located behind the glovebox **3**.

Certain fuses should only be replaced by a qualified professional. These fuses are not listed on the label.

Only change the fuses represented on the label.

## FUSES (4/4)

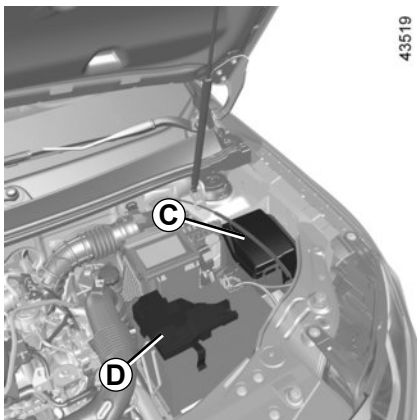

### Fuses in the engine compartment C and D

Some functions are protected by fuses located in the engine compartment in units **C** and **D**.

However, because of their reduced accessibility, **we advise you to have your fuses replaced by an approved dealer.**



When working in the engine compartment, ensure that the windscreen wiper stalk is in the park position.

**Risk of injury.**

**C**

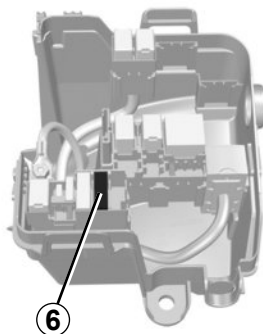

### LPG fuse in the engine compartment C

LPG fuse **6**: LPG circuit shut-off or LPG circuit and petrol circuit shut-off.



Before performing any action in the engine compartment, the ignition must be switched off (please see the information on “Starting, stopping the engine” in Section 2).



Deactivate the Stop and Start function for any operation performed in the engine compartment.



Please note when working close to the engine that it may be hot. The engine cooling fan may also start

at any moment. The  warning light in the engine compartment reminds you of this.

**Risk of injury.**

## BATTERY: troubleshooting (1/3)

### To avoid all risk of sparks:

- Ensure that any power consumers (courtesy lights etc.) are switched off before disconnecting or reconnecting a battery;
- when charging, stop the charger before connecting or disconnecting the battery;
- to avoid creating a short circuit between the terminals, do not place metal objects on the battery;
- always wait at least one minute after the engine has been switched off before disconnecting a battery;
- make sure that you reconnect the battery terminals after refitting.



Before performing any action in the engine compartment, the ignition must be switched off (please see the information on “Starting, stopping the engine” in Section 2).

### Connecting a battery charger

**The charger must be compatible with a battery with a nominal voltage of 12 volts.**

Do not disconnect the battery while the engine is running. **Follow the instructions given by the manufacturer of the battery charger you are using.**

When lots of accessories are fitted to the vehicle, have them connected to the + after ignition feed.



Special procedures may be required to charge some batteries. Contact your authorised dealer.

Avoid all risk of sparks which may cause an immediate explosion, and charge the battery in a well ventilated area.

**Risk of serious injury.**



Handle the battery with care as it contains sulphuric acid, which must not come into contact with eyes or skin. If it does, wash the affected area with plenty of cold water. If necessary, consult a doctor.

Ensure that naked flames, red hot objects and sparks do not come into contact with the battery as there is a risk of explosion.

Please note when working close to the engine that it may be hot. In addition, the engine cooling fan may

start at any moment. The  warning light in the engine compartment reminds you of this.

**Risk of injury.**

## BATTERY: troubleshooting (2/3)

### Starting the vehicle using the battery from another vehicle

If you have to use the battery from another vehicle to start, obtain suitable jump leads (with a large cross section) from an approved dealer or, if you already have jump leads, ensure that they are in perfect condition.

**The two batteries must have an identical nominal voltage of 12 volts.** The battery supplying the current should have a capacity (amp-hours, Ah) which is at least the same as that of the discharged battery.

Ensure that there is no risk of contact between the two vehicles (risk of short circuiting when the positive terminals are connected) and that the discharged battery is properly connected. Switch off your vehicle ignition.

Start the engine of the vehicle supplying the current and run it at an intermediate engine speed.

In the event of a battery fault (battery disconnected, discharged, etc.), a reset of the power-assisted steering must be carried out: refer to the information on "Steering wheel, Power-assisted steering" in section 1).

## BATTERY: troubleshooting (3/3)

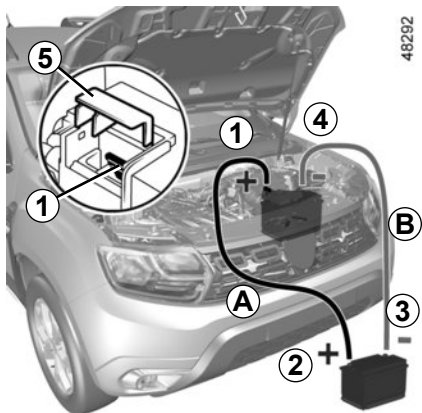

Lift the red cover **5** on the terminal (+) **1**.

Attach the positive lead (+) **A** to the terminal (+) **1** of the discharged battery, then to the terminal (+) **2** of the battery supplying the current.

Connect the negative cable (-) **B** to the terminal (-) **3** of the battery supplying the current and then to the terminal (-) **4** of the discharged battery.

Start the engine as normal. As soon as it is running, disconnect leads **A** and **B** in the reverse order (**4-3-2-1**)



Please note when working close to the engine that it may be hot. The engine cooling fan may also start

at any moment. The  warning light in the engine compartment reminds you of this.

**Risk of injury.**



Check that there is no contact between leads **A** and **B** and that the positive lead **A** is not touching any metal parts on the vehicle supplying the current.

**Risk of injury and/or damage to the vehicle.**

# RADIO FREQUENCY REMOTE CONTROL: batteries (1/2)

## Operating faults

If the battery is too weak to ensure correct operation, you can still start and lock/unlock the vehicle (please refer to the information on “Locking/unlocking the opening elements” in Section 1).

The batteries are available from approved Dealers, and their service life approximately two years.

Check that there is no dye on the battery: risk of an incorrect electrical contact.



When they need to be replaced, be sure to use the same or equivalent type of battery (consult an Approved Dealer).

40618



## Replacing the battery

Open the case at slot **1** using a flat-blade screwdriver or similar, and replace the battery **2**, observing the type and polarity shown on the back of the cover.

Ensure that the cover is correctly clipped on and the screw tightened.

**Note:** It is not advisable to touch the electronic circuit in the key cover when replacing the battery.

40619

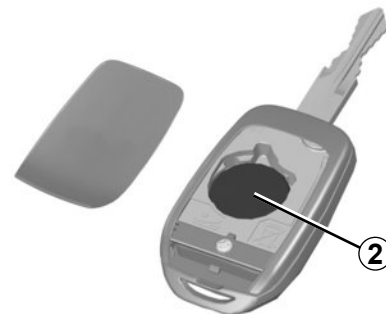

When replacing:

– make sure that the batteries are correctly inserted.

### Risk of explosion.

– if the flap does not close correctly, do not use and keep out of reach of children.

## RADIO FREQUENCY REMOTE CONTROL: batteries (2/2)

53757



### Precautions relating to batteries:

- keep (new or used) batteries out of reach of children;

- do not swallow batteries;

### **Risk of chemical burns which may prove fatal.**

- if ingested or inserted into any part of the body, consult a doctor as soon as possible.

53758

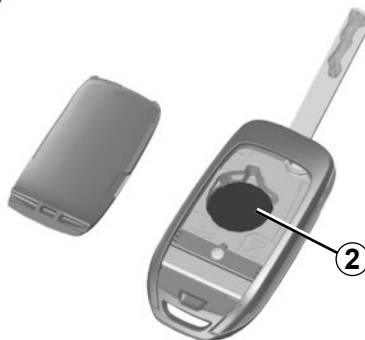

Do not throw away your used batteries; give them to an organisation responsible for collecting and recycling batteries.

26913



## “HANDS-FREE” CARD: battery (1/2)

### Operating faults

If the battery is too weak to ensure correct operation, you can still start and lock/unlock the vehicle (please refer to the information on “Locking/unlocking the opening elements” in Section 1).



When they need to be replaced, be sure to use the same or equivalent type of battery (consult an Approved Dealer).



When replacing:

– make sure that the batteries are correctly inserted.

#### Risk of explosion.

– if the flap does not close correctly, do not use and keep out of reach of children.

40303



### Replacing the battery

When the message “Keycard Battery Low” appears on the instrument panel, replace the battery in the card:

- slide the rear casing **1** downwards while pressing on zone **A**;
- remove the battery cover **2**;
- remove the battery by pressing on one side and lifting the other;
- replace it according to the direction and template shown inside the cover.

43532

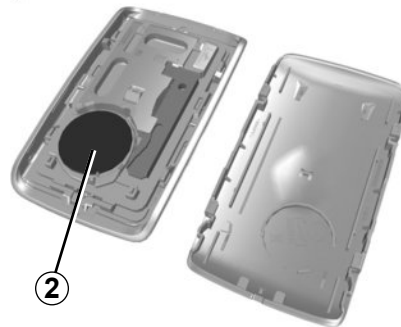

When refitting, proceed in the reverse order, then press one of the buttons on the card four times, close to the vehicle: the message will disappear.

Check that the cover is clipped shut.

**Note:** Do not touch the electronic circuit or contacts on the card when replacing the battery.



## “HANDS-FREE” CARD: battery (2/2)



### Precautions relating to batteries:

- keep (new or used) batteries out of reach of children;
- do not swallow batteries;

### **Risk of chemical burns which may prove fatal.**

- if ingested or inserted into any part of the body, consult a doctor as soon as possible.

The batteries are available from approved Dealers, and their service life approximately two years. Check that there is no dye on the battery: risk of an incorrect electrical contact.

26613



Do not throw away your used batteries; give them to an organisation responsible for collecting and recycling batteries.

# WIPER BLADES: replacement

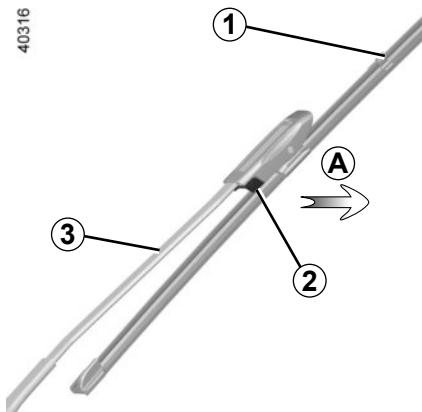

## Windscreen wiper blades 1

Ignition switched off, lift the wiper arm 3, pull tab 2 (movement A) and push the blade upwards.

### Refitting

Slide the blade along the arm until it clips on. Check that the bonnet is correctly locked. The wiper arm on the driver's side must always be on top.



Before changing the wiper blade, make sure the stalk is in the off position (deactivated).

**Risk of injury.**

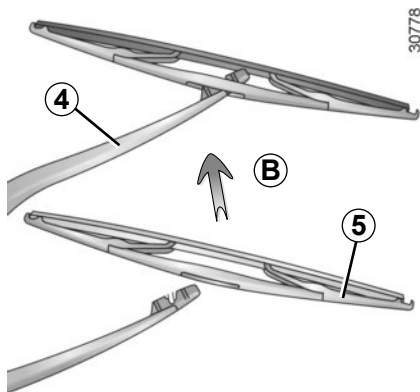

## Replacing the rear screen wiper blade 5

- With the ignition switched off, lift wiper arm 4;
- pivot the blade 5 until some resistance is met;
- pull the blade to release it (movement B).

### Refitting

To refit the wiper blade, proceed in reverse order to removal. Make sure that the blade is correctly locked in position.

Check the condition of the wiper blades. You are responsible for their service life:

- clean the blades, windscreen and rear screen regularly with soapy water;
- do not use them when the windscreen or rear screen are dry;
- free them from the windscreen or rear screen when they have not been used for a long time.



– In frosty weather, make sure that the wiper blades are not stuck by ice (to avoid the risk of the motor overheating).

- Check the condition of the wiper blades.

Replace the wiper blades as soon as they begin to lose efficiency (approximately once a year).

Whilst changing the blade, take care not to drop the arm onto the window after it has been removed as this may break the window.

## TOWING: breakdown (1/4)

Before towing, put the gearbox in neutral, unlock the steering column and release the parking brake.

For vehicles fitted with an automatic gearbox, if it is not possible to put the gear lever into position **N**, please consult an authorised dealer.

### Steering column unlocking

Insert the key in the ignition-starter switch and turn it to the “**On**” position. Depending on the vehicle, place the card on the symbol and press the engine start button for **two seconds**.

Reposition the lever to neutral (position **N** for vehicles fitted with an automatic gearbox).

The steering column unlocks, the accessory functions are powered: you can use the vehicle's lights (direction indicators, brake lights, etc.). At night the vehicle must have its lights on.

Depending on the vehicle, once you have finished towing, press the engine start button twice (risk of running down the battery).



- Use a rigid towing bar. If a rope or cable is used (where the law allows this), the vehicle being towed must be able to brake.
- A vehicle must not be towed if it is not fit to be driven.
- Avoid accelerating or braking suddenly when towing, as this may result in damage being caused to the vehicle.
- In any case, it is advisable not to exceed **16 mph (25 km/h)**.
- Do not push the vehicle if the steering column is locked.

## TOWING: breakdown (2/4)

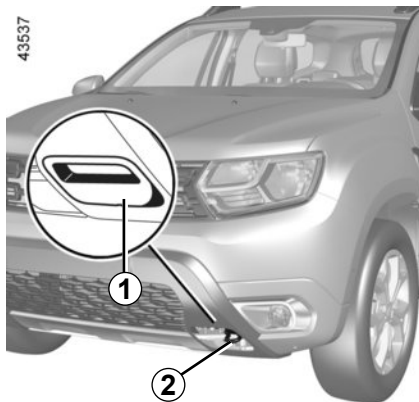

### Front and rear towing points

**Only use the front 2 and rear 4** towing points.

Unclip front **1** or rear **3** cover by inserting a flat-blade screwdriver or similar under the cover.



Ensure that the towing eye is bolted correctly.

**Risk of losing the towed object.**

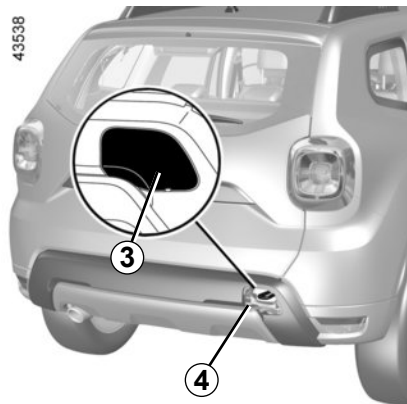

These towing points may only be used for towing; never use them for lifting the vehicle directly or indirectly.



When the engine is stopped, steering and braking assistance are not operational.



Do not leave the tools unsecured inside the vehicle as they may come loose under braking.

## TOWING: breakdown (3/4)



### 4-wheel drive vehicles (4WD)

Whichever type of gearbox is fitted, a 4WD vehicle must never be towed if any of its 4 wheels are touching the ground.



Do not remove the key from the ignition when the vehicle is being towed.

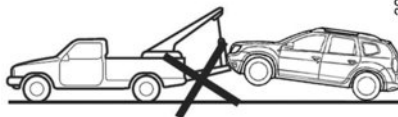

You must never tow a 4-wheel drive vehicle, irrespective of the mode selected, if one of the 4 wheels is in contact with the ground (except for off-road recovery).

**Risk of mechanical damage.**

### Off-road recovery

If your vehicle is stuck in sand, snow or mud, attach a flexible towing device (towing belt or other device specially designed for this purpose) to the front or rear towing point (refer to the information on "Front and rear towing points" on the previous page).

Refer to the manufacturer's instructions for information on how to fit and operate the equipment.

If a **4x4 (4WD)** vehicle becomes stuck, it should only be towed for a short distance. **Risk of mechanical damage.**



For off-road recovery, it is forbidden to use a rigid bar to tow a vehicle that is stuck. **Risk of mechanical damage.**

## TOWING: breakdown (4/4)

### Towing a vehicle with an automatic gearbox

When the engine is switched off, the gearbox is no longer lubricated. It is preferable to tow this type of vehicle on a trailer or, for **4x2 (2WD)** vehicles only, tow it with the rear wheels off the ground.

**Under exceptional circumstances** and for **4x2 (2WD)** vehicles only, you may tow the vehicle with all four wheels on the ground, only going forward, with the gear lever in neutral position **N** and for a distance not exceeding 31 miles (50 km).

If the gear lever cannot be put into the **N** position, please consult an authorised dealer.



When storing the tools, ensure they are securely replaced in the luggage compartment, in their original position.

Do not leave the tools unsecured inside the vehicle as they may come loose under braking.

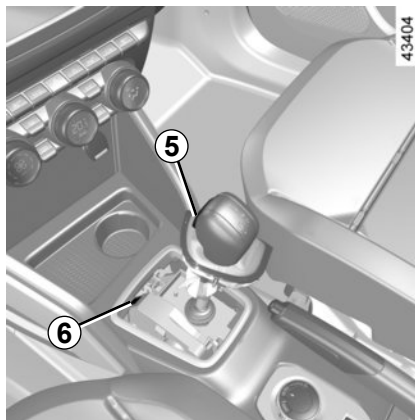

When setting off, if the lever is locked in position **P** even though you are pressing the brake pedal, the lever can be released manually.

To do this, unclip the base of the lever, then insert a tool (rigid rod) into the slot **6** and press simultaneously on the button **5** in order to unlock the lever.

Contact an authorised dealer as soon as possible.

# FITTED AUDIO EQUIPMENT

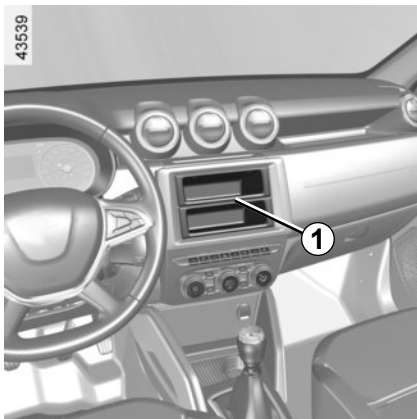

If your vehicle is not fitted with an audio system, one can be fitted and locations have been provided for:

- the radio **1**;
- front speakers **2** and **3**;
- rear speakers **4**.

To install any equipment, please consult an approved dealer.

## Radio location 1

Unclip the blanking cover. The aerial, + and – supply and speaker wire connections are located behind it.

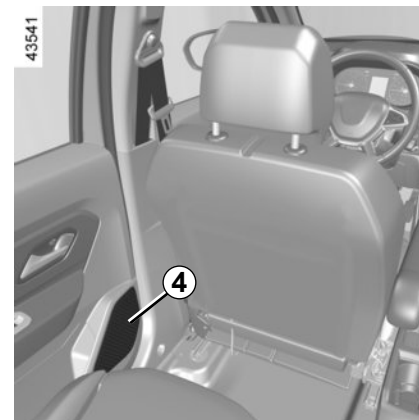
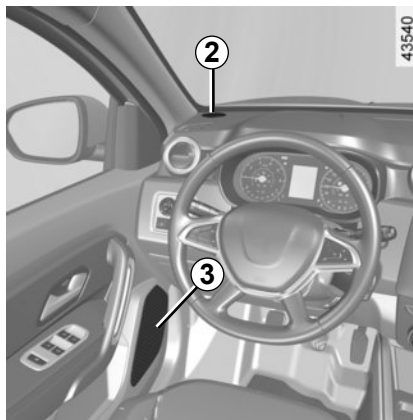

- In all cases, it is very important to follow the manufacturer's instructions carefully.
- The specifications of the brackets and wires (available from our network) vary depending on the equipment level of your vehicle and the type of radio. Consult an authorised dealer to find out the correct part number.
- No work may be carried out on the vehicle's electrical or radio circuits, except by approved Dealers: an incorrectly connected system may result in damage being caused to the electrical equipment and/or the components connected to it.

# ACCESSORIES



## Electrical and electronic accessories

Before installing this type of accessory (particularly for transmitters/receivers: frequency bandwidth, power level, position of the aerial, etc.), make sure it is compatible with your vehicle. You can get advice from an authorised dealer.

Before connecting an accessory to a socket, please ensure that you do not exceed the maximum power authorised for the socket: please refer to the information on “Multimedia equipment” and “Ashtrays, Cigarette lighter, Accessories sockets” in Section 3. **Fire hazard.**

No work may be carried out on the vehicle’s electrical or radio circuits, except by authorised dealers: an incorrectly connected system may result in damage being caused to the electrical equipment and/or the components connected to it.

If the vehicle is fitted with any aftermarket electrical equipment, make sure that the installation is correctly protected by a fuse. Establish the rating and position of this fuse.

### Using the diagnostic socket

The use of electronic accessories on the diagnostic socket may cause serious disturbance to the vehicle’s electronic systems. For your safety we recommend that you use only electronic accessories approved by the manufacturer, consult an Approved Dealer. **Serious accident risk.**

### Fitting aftermarket accessories

If you wish to install accessories on the vehicle: please contact an authorised dealer. Also, to ensure the correct operation of your vehicle, and to avoid any risk to your safety, we recommend that you use only accessories specifically designed for your vehicle, which are the only accessories for which the manufacturer will provide a warranty.

If you are using an anti-theft device, only attach it to the brake pedal.

### Obstructions to the driver

On the driver’s side, only use mats suitable for the vehicle, attached with the pre-fitted components, and check the fitting regularly. Do not lay one mat on top of another. **There is a risk of wedging the pedals.**



## OPERATING FAULTS (1/9)

### Using the card

The card does not lock or unlock the doors.

### POSSIBLE CAUSES

Card battery is flat.

Use of appliances operating on the same frequency as the card (mobile phone, etc.).

Vehicle located in a high electromagnetic radiation zone.

Vehicle battery flat.

The message “Place Card Near Symbol + START” appears on the instrument panel.

The vehicle is started.

### WHAT TO DO

Replace the battery. You can still lock/unlock and start your vehicle (refer to the information on “Locking/unlocking the doors” in Section 1 and “Starting/Stopping the engine” in Section 2).

Stop using the equipment or use the integrated key (refer to the information on “Locking, unlocking the opening elements” in Section 1).

Use the key integrated in the card (refer to the information on “Locking, unlocking the opening elements” in Section 1).

Place the card on the start symbol until the instrument panel message stops being displayed, then press the starting button within 2 seconds of the message going out.

With the engine running, the card’s locking/unlocking device is blocked. Turn off the ignition.

## OPERATING FAULTS (2/9)

### Using the card

The card does not lock or unlock the doors.

### POSSIBLE CAUSES

Desynchronisation of the card.

### WHAT TO DO

Unlock the driver's door by inserting the key integrated into the card into the door lock (see the paragraph on "Locking, unlocking the opening elements" in Section 1), then place the card on the symbol **4** (see the paragraph on "Starting, stopping the engine: vehicle with card" in Section 2) and press the button **2** to synchronise the card.

## OPERATING FAULTS (3/9)

The following advice will enable you to carry out quick, temporary repairs. For safety reasons you should always contact an approved dealer as soon as possible.

Using the remote control	POSSIBLE CAUSES	ACTION REQUIRED
The remote control does not lock or unlock the doors.	The remote control battery is flat.	Use the emergency key.
	Use of appliances operating on the same frequency as the remote control (mobile phone, etc.).	Stop using the devices or use the key.
	Vehicle located in a high electromagnetic radiation zone. Discharged battery.	Replace the battery. You can still lock/unlock and start your vehicle (refer to the information on "Locking/unlocking the doors" in Section 1 and "Starting/Stopping the engine" in Section 2).
	The vehicle is started.	With the engine running, the key's locking/unlocking device is blocked. Turn off the ignition.
	Desynchronisation of the remote control.	Unlock the driver's door using the key in the door lock, then start the engine to synchronise the remote control.

## OPERATING FAULTS (4/9)

<b>The starter is activated</b>	<b>POSSIBLE CAUSES</b>	<b>WHAT TO DO</b>
The instrument panel indicator lights are weak or fail to light up and the starter does not turn.	Battery terminals not tight, battery terminals disconnected or oxidised.	Retighten or reconnect the terminals, or clean them if they are oxidised.
	Discharged battery or not operational.	Connect another battery to the faulty battery. Refer to the paragraph "Battery: troubleshooting" in section 5 or replace the battery if necessary. Do not push the vehicle if the steering column is locked.
	Faulty circuit.	Consult an approved dealer.
The engine will not start.	Starting conditions are not fulfilled.	Please refer to the information on "Starting, stopping the engine" in Section 2.
	The "hands-free" card does not work.	Please refer to the information on "Starting, stopping the engine" in Section 2.
With the vehicle stationary, engine cold, the engine's idle speed is high.	Petrol version, this is not necessarily a fault. This may be caused by the increase in the engine temperature.	The engine's idle speed should decrease after about one minute. Otherwise, this may be caused by another fault. Consult an approved dealer.

## OPERATING FAULTS (5/9)

<b>The starter is activated</b>	<b>POSSIBLE CAUSES</b>	<b>WHAT TO DO</b>
The engine cannot be switched off.	Card not detected.	Press and hold the start button.
	Electronic fault.	Press the start button quickly five times.
The steering column remains locked.	Steering wheel locked.	Move the steering wheel while pressing the engine start button (please refer to Section 2 “Starting, stopping the engine”).
	Faulty circuit.	Consult an approved dealer.

## OPERATING FAULTS (6/9)

On the road	POSSIBLE CAUSES	WHAT TO DO
Vibrations.	Tyres not inflated to correct pressures, incorrectly balanced or damaged.	Check the tyre pressures: if this is not the problem, have them checked by an approved Dealer.
White smoke from the exhaust.	In the diesel version, this is not necessarily a fault. Smoke may be caused by particle filter regeneration.	Refer to the information on “Special features of diesel versions” in Section 2.
	Petrol version, this is not necessarily a fault. Depending on the climate conditions (cold, humidity etc.), smoke may be produced under hard vehicle acceleration.	Reduce the engine speed and avoid sudden acceleration to gradually make the smoke disappear. Otherwise, this may be caused by another fault. Consult an approved dealer.
Smoke under the bonnet.	Short-circuit or cooling system leak.	Stop, switch off the ignition, stand away from the vehicle and contact an approved dealer.
The oil pressure warning light comes on:		
while cornering or braking	The level is too low.	Top up the engine oil level (refer to the information on “Engine oil level: topping up/ filling” in Section 4).
is slow to go out or remains lit under acceleration	Loss of oil pressure.	Stop the vehicle and contact an approved Dealer.

## OPERATING FAULTS (7/9)

On the road	POSSIBLE CAUSES	WHAT TO DO
Steering becomes heavy.	Assistance overheating. Fault with the electric assistance motor. Fault in the assistance system.	Drive carefully at reduced speed, be aware of the level of force in the steering wheel needed to turn the wheels. Consult an approved dealer
The engine is overheating. The coolant temperature indicator is in the warning zone and warning light <b>STOP</b> comes on.	Engine cooling fan not working.	Stop the vehicle, switch off the engine and contact an approved dealer.
	Coolant leaks.	Check the coolant reservoir: it should contain fluid. If there is no coolant, consult an authorised dealer as soon as possible.
Coolant boiling in the coolant reservoir.	Mechanical fault: damaged cylinder head gasket.	Stop the engine. Contact an approved dealer.



**Radiator:** If there is a significant lack of coolant, remember that it must never be topped up using cold coolant when the engine is very hot. After any procedure on the vehicle which has involved even partial draining of the cooling system, it must be refilled with a new mixture prepared in the correct proportions. Reminder: only products approved by our Technical Department may be used for this purpose.

## OPERATING FAULTS (8/9)

<b>Electrical equipment</b>	<b>POSSIBLE CAUSES</b>	<b>WHAT TO DO</b>
The wipers do not work.	Wiper blades stuck.	Free the blades before using the wipers.
	Faulty electrical circuit.	Consult an approved dealer.
	Fuse damaged.	Replace the fuse or have it replaced; refer to the information on "Fuses" in section 5.
The wiper does not stop.	Faulty electrical controls.	Consult an approved dealer.
Direction indicators flashing more quickly.	Blown bulb.	See information on "Headlights: changing bulbs" in section 5.
The direction indicators do not work.	Faulty electrical circuit or control.	Consult an approved dealer.
	Fuse damaged.	Replace the fuse or have it replaced; refer to the information on "Fuses" in section 5.
The lights do not come on or go off.	Faulty electrical circuit or control.	Consult an approved dealer.
	Fuse damaged.	Replace the fuse or have it replaced; refer to the information on "Fuses" in section 5.



## OPERATING FAULTS (9/9)

<b>Electrical equipment</b>	<b>POSSIBLE CAUSES</b>	<b>WHAT TO DO</b>
<p>Traces of condensation in the headlights or rear lights.</p>	<p>Traces of condensation may be a natural phenomenon caused by variations in temperature and humidity.</p> <p>In this case, the traces will disappear slowly once the lights are switched on.</p>	
<p>The front seat belt reminder light comes on when the seat belts are fastened.</p>	<p>An object is stuck between the floor and the seat and is disrupting the operation of the sensor.</p>	<p>Remove all objects from underneath the front seats.</p>



# ***Section 6: Technical specifications***

Vehicle identification plate . . . . .	6.2
Technical Information for the emergency services . . . . .	6.3
Engine identification . . . . .	6.4
Dimensions . . . . .	6.6
Engine specifications. . . . .	6.7
Weights/Towing weights . . . . .	6.9
Replacement parts and repairs . . . . .	6.10
Service sheets . . . . .	6.11
Anticorrosion check . . . . .	6.17

# VEHICLE IDENTIFICATION PLATE

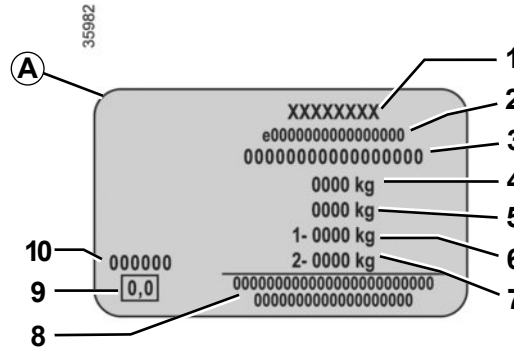
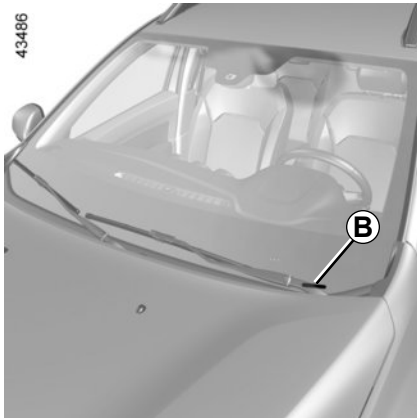
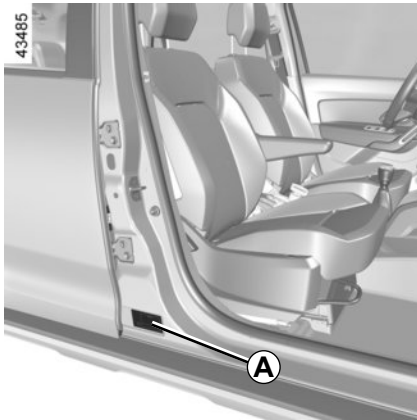

**Quote the details given on identification plate A on all letters or orders.**

**The presence and location of the information depends on the vehicle.**

## Vehicle identification plate A

- 1 Manufacturer name.
- 2 EC design number or approval number.
- 3 Identification number.  
**Depending on the vehicle, this information is also provided on the marking B.**
- 4 MMAC (Maximum Authorised Mass).

- 5 MTR (Gross Train Weight: vehicle fully loaded, with trailer).
- 6 MMTA (Maximum Permissible Weight) for front axle.
- 7 MMTA on rear axle.
- 8 Reserved for related or additional entries.
- 9 Diesel exhaust emissions.  
**Depending on the vehicle, this information is not indicated on the manufacturer's plate but on the engine smoke opacity label (refer to the information on "Special features of Diesel versions" in Section 2).**
- 10 Paint reference (colour code).

## TECHNICAL INFORMATION FOR THE EMERGENCY SERVICES

57591



57729

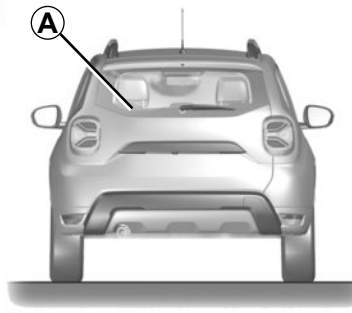

The QR code on the **A** label allows emergency workers using a tablet or smartphone to immediately access the technical information useful for working on the vehicle in the event of an accident.

Ensure that the **A** label is always visible and present on the windscreen as well as the rear screen.

**Any modification or damage would prevent access to the information.**

# ENGINE IDENTIFICATION (1/2)

33293

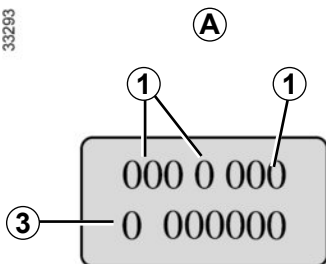

**Please quote the engine identification information in area A in all correspondence or orders.**

(Location varies depending on engine)

- 1 Engine type.
- 2 Engine suffix.
- 3 Engine serial number.

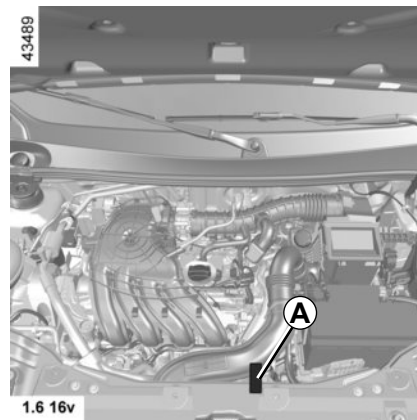
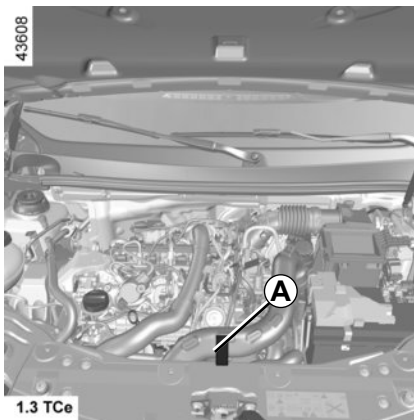
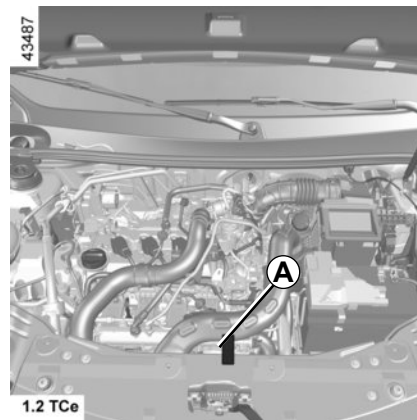
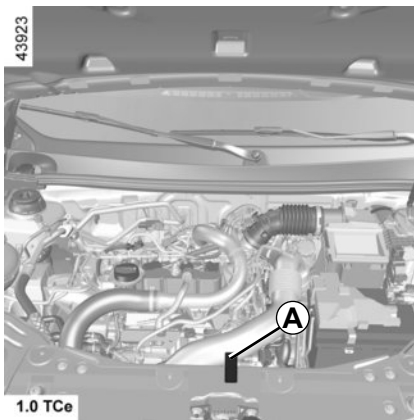

## ENGINE IDENTIFICATION (2/2)

33293

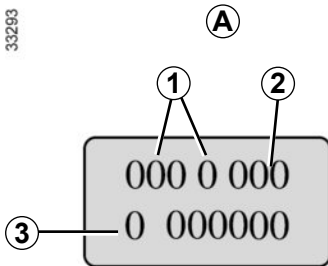

**Please quote the engine identification information in area A in all correspondence or orders.**

(Location varies depending on engine)

- 1 Engine type.
- 2 Engine suffix.
- 3 Engine serial number.

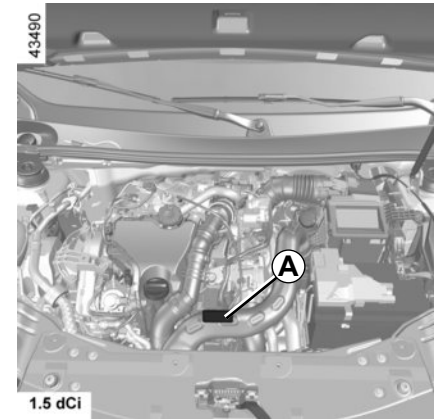
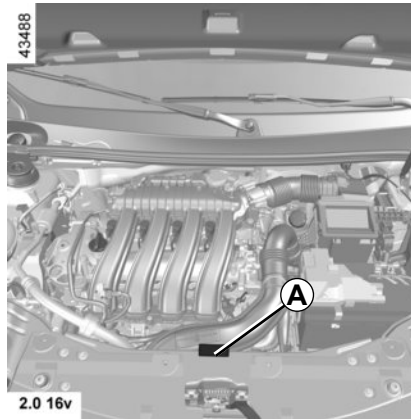

# DIMENSIONS (in metres)

58639

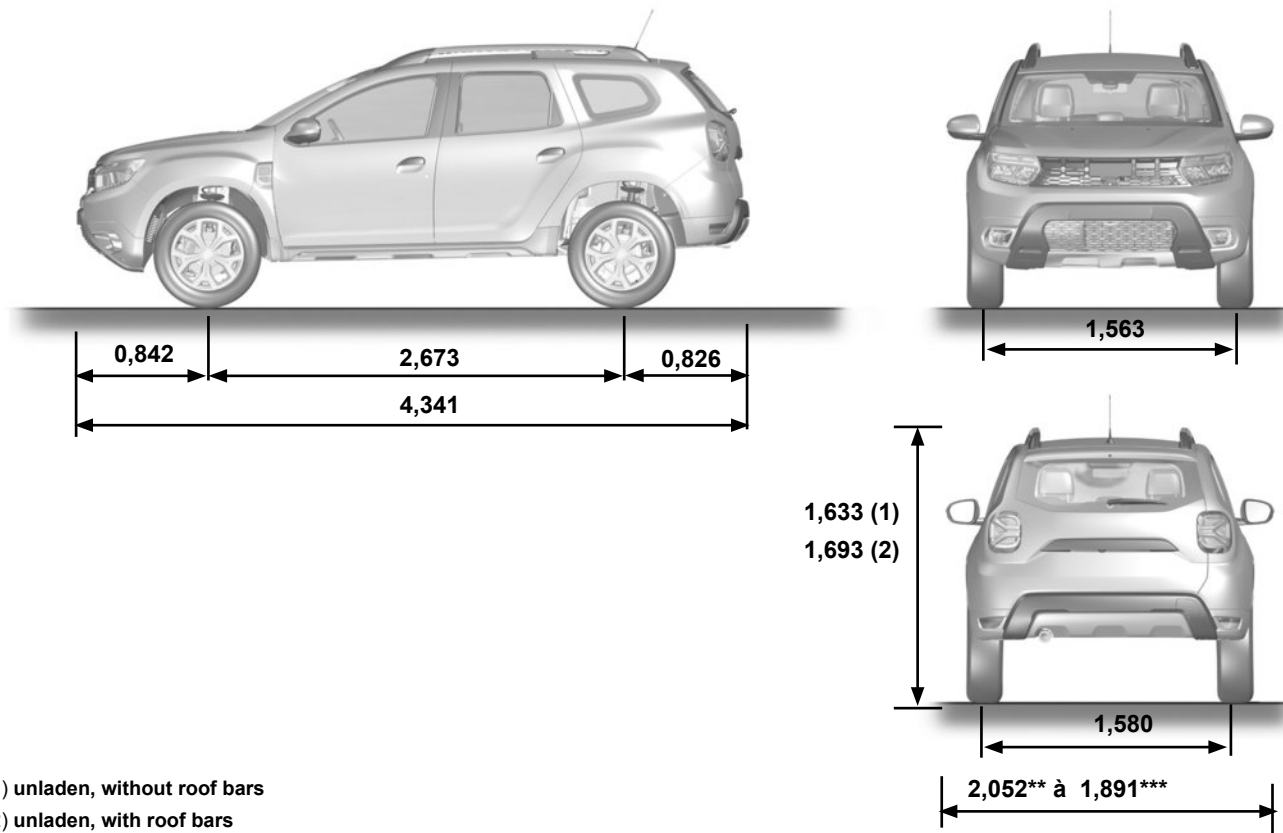

(1) unladen, without roof bars

(2) unladen, with roof bars

\*\* with door mirrors folded out





\*\*\* with door mirrors folded in



## ENGINE SPECIFICATIONS (1/2)

Versions	1.0 TCe	1.2 TCe	1.3 TCe	1.6 16V	2.0 16V	1.5 dCi
<b>Engine type</b> (see engine plate)	H4Dt	H5Ft	H5H Turbo	H4M	F4R	K9K
<b>Cubic capacity (cc)</b>	999	1 198	1332	1598	1998	1461
<b>Type of fuel</b> <b>Octane rating</b>	Petrol It is <b>essential</b> that you use unleaded petrol of the octane rating stated on the label inside the fuel filler flap.				Diesel The label located in the fuel filler flap indicates authorised fuels.	
<b>Spark plugs</b>	Only use spark plugs specified for your vehicle's engine. The type should be marked on a label stuck inside the engine compartment. If it is not then contact your authorised dealer. Fitting spark plugs other than those specified may damage the engine.					

## ENGINE SPECIFICATIONS (2/2)

Versions	1.0 TCe	1.2 TCe	1.3 TCe	1.6 16V	2.0 16V	1.5 dCi
<b>Engine type</b> (see engine plate)	H4Dt	H5Ft	H5H Turbo	H4M	F4R	K9K
<b>Cubic capacity (cc)</b>	999	1 198	1332	1598	1998	1461
<b>Fuel types that meet European standards and are compatible with the engines of vehicles sold in Europe</b> (in any other case, contact an Approved Dealer).			Unleaded petrol compliant with standard <b>EN 228</b> contains up to 5% ethanol in volume.		 Diesel fuel compliant with standard <b>EN 590</b> contains up to 7% fatty acid methyl ester in volume.	
			Unleaded petrol compliant with standard <b>EN 228</b> contains up to 10% ethanol in volume.		 Diesel fuel compliant with standard <b>EN 16734</b> contains up to 10% fatty acid methyl ester in volume.	
					 Diesel fuel compliant with standard <b>EN 15940</b> contains up to 7% acid methyl ester in volume.	

## WEIGHTS (in kg)

The weights shown are for a basic vehicle without options: they will vary depending on the equipment level of your vehicle. Please consult an authorised dealer.

Versions	4x2	4x4
<b>Maximum Authorised Mass (MMAC) Gross Train Weight (MTR)</b>	Weights shown on the vehicle identification plate (refer to the information on "Vehicle identification plates" in Section 6)	
<b>Braked Trailer Weight*</b>	found by calculating: <b>MTR - MMAC</b>	
<b>Unbraked trailer weight*</b>	625	675
<b>Permissible nose weight*</b>	75	
<b>Maximum permissible load on roof with a carrying device</b>	80 (including the carrying device)	

### \*Towing weight (towing a caravan, boat, etc.)

Towing is prohibited when the GTW - MAM calculation is equal to zero, or when the GTW is equal to zero (or is not listed) on the identification plate.

- It is important to comply with the towing weights, governed by local legislation in each country and, in particular, laid down in the Road Traffic Regulations. Contact an authorised dealer for any towing equipment modifications.
- For vehicles fitted with a trailer, **the gross train weight (vehicle + trailer) must never be exceeded**. However, the following is tolerated:
  - the Maximum permissible weight at the rear may be exceeded by no more than 15%,
  - the maximum permissible all-up weight may be exceeded by no more than 10% or 100 kg (whichever occurs first).
 In either case, the maximum speed of the vehicle and trailer must not exceed 50 mph (80 km/h) and the tyre pressure must be increased by 0.2 bar (3 psi).
- The engine output and climbing capability are reduced with altitude. We recommend that the maximum load be reduced by 10% at an altitude of 1,000 metres and by an additional 10% for each 1,000 metres thereafter.

### Weight transfer (4x2 versions only)

If the Maximum Authorised Mass of the vehicle has not been reached, up to 300 kg can be transferred to the braked trailer, within the limits of the Gross Train Weight.

## **SPARE PARTS AND REPAIRS**

Original parts are based on strict specifications and are subject to highly-specialised tests. Therefore, they are of at least the same level of quality as the parts fitted originally.

If you always fit genuine replacement parts to your vehicle, you will ensure that it performs well. Furthermore, repairs carried out within the manufacturer's Network using original parts are guaranteed according to the conditions set out on the reverse of the repair order.

# SERVICE SHEETS (1/6)

VIN: .....

Date: _____ Miles (Km): _____		Invoice number: _____		Comments/miscellaneous	
<b>Type of operation:</b>		<b>Stamp</b>			
Service <input type="checkbox"/>					
..... <input type="checkbox"/>					
<b>Anti-corrosion check:</b>					
OK <input type="checkbox"/> Not OK* <input type="checkbox"/>					
*See specific page					

Date: _____ Miles (Km): _____		Invoice number: _____		Comments/miscellaneous	
<b>Type of operation:</b>		<b>Stamp</b>			
Service <input type="checkbox"/>					
..... <input type="checkbox"/>					
<b>Anti-corrosion check:</b>					
OK <input type="checkbox"/> Not OK* <input type="checkbox"/>					
*See specific page					

Date: _____ Miles (Km): _____		Invoice number: _____		Comments/miscellaneous	
<b>Type of operation:</b>		<b>Stamp</b>			
Service <input type="checkbox"/>					
..... <input type="checkbox"/>					
<b>Anti-corrosion check:</b>					
OK <input type="checkbox"/> Not OK* <input type="checkbox"/>					
*See specific page					

# SERVICE SHEETS (2/6)

VIN: .....

Date: _____ Miles (Km): _____		Invoice number: _____		Comments/miscellaneous	
<b>Type of operation:</b>		<b>Stamp</b>			
Service <input type="checkbox"/>					
..... <input type="checkbox"/>					
<b>Anti-corrosion check:</b>					
OK <input type="checkbox"/> Not OK* <input type="checkbox"/>					
*See specific page					

Date: _____ Miles (Km): _____		Invoice number: _____		Comments/miscellaneous	
<b>Type of operation:</b>		<b>Stamp</b>			
Service <input type="checkbox"/>					
..... <input type="checkbox"/>					
<b>Anti-corrosion check:</b>					
OK <input type="checkbox"/> Not OK* <input type="checkbox"/>					
*See specific page					

Date: _____ Miles (Km): _____		Invoice number: _____		Comments/miscellaneous	
<b>Type of operation:</b>		<b>Stamp</b>			
Service <input type="checkbox"/>					
..... <input type="checkbox"/>					
<b>Anti-corrosion check:</b>					
OK <input type="checkbox"/> Not OK* <input type="checkbox"/>					
*See specific page					

# SERVICE SHEETS (3/6)

VIN: .....

Date: _____ Miles (Km): _____		Invoice number: _____		Comments/miscellaneous	
<b>Type of operation:</b>		<b>Stamp</b>			
Service <input type="checkbox"/>					
..... <input type="checkbox"/>					
<b>Anti-corrosion check:</b>					
OK <input type="checkbox"/> Not OK* <input type="checkbox"/>					
*See specific page					
Date: _____ Miles (Km): _____		Invoice number: _____		Comments/miscellaneous	
<b>Type of operation:</b>		<b>Stamp</b>			
Service <input type="checkbox"/>					
..... <input type="checkbox"/>					
<b>Anti-corrosion check:</b>					
OK <input type="checkbox"/> Not OK* <input type="checkbox"/>					
*See specific page					
Date: _____ Miles (Km): _____		Invoice number: _____		Comments/miscellaneous	
<b>Type of operation:</b>		<b>Stamp</b>			
Service <input type="checkbox"/>					
..... <input type="checkbox"/>					
<b>Anti-corrosion check:</b>					
OK <input type="checkbox"/> Not OK* <input type="checkbox"/>					
*See specific page					

# SERVICE SHEETS (4/6)

VIN: .....

Date:	Miles (Km):	Invoice number:	Comments/miscellaneous
<b>Type of operation:</b>		<b>Stamp</b>	
Service	<input type="checkbox"/>		
.....	<input type="checkbox"/>		
<b>Anti-corrosion check:</b>			
OK	<input type="checkbox"/>	Not OK*	<input type="checkbox"/>
*See specific page			

Date:	Miles (Km):	Invoice number:	Comments/miscellaneous
<b>Type of operation:</b>		<b>Stamp</b>	
Service	<input type="checkbox"/>		
.....	<input type="checkbox"/>		
<b>Anti-corrosion check:</b>			
OK	<input type="checkbox"/>	Not OK*	<input type="checkbox"/>
*See specific page			

Date:	Miles (Km):	Invoice number:	Comments/miscellaneous
<b>Type of operation:</b>		<b>Stamp</b>	
Service	<input type="checkbox"/>		
.....	<input type="checkbox"/>		
<b>Anti-corrosion check:</b>			
OK	<input type="checkbox"/>	Not OK*	<input type="checkbox"/>
*See specific page			



# SERVICE SHEETS (5/6)

VIN: .....

Date: _____ Miles (Km): _____		Invoice number: _____		Comments/miscellaneous	
<b>Type of operation:</b>		<b>Stamp</b>			
Service <input type="checkbox"/>					
..... <input type="checkbox"/>					
<b>Anti-corrosion check:</b>					
OK <input type="checkbox"/> Not OK* <input type="checkbox"/>					
*See specific page					

Date: _____ Miles (Km): _____		Invoice number: _____		Comments/miscellaneous	
<b>Type of operation:</b>		<b>Stamp</b>			
Service <input type="checkbox"/>					
..... <input type="checkbox"/>					
<b>Anti-corrosion check:</b>					
OK <input type="checkbox"/> Not OK* <input type="checkbox"/>					
*See specific page					

Date: _____ Miles (Km): _____		Invoice number: _____		Comments/miscellaneous	
<b>Type of operation:</b>		<b>Stamp</b>			
Service <input type="checkbox"/>					
..... <input type="checkbox"/>					
<b>Anti-corrosion check:</b>					
OK <input type="checkbox"/> Not OK* <input type="checkbox"/>					
*See specific page					

# SERVICE SHEETS (6/6)

VIN: .....

Date: _____ Miles (Km): _____		Invoice number: _____		Comments/miscellaneous	
<b>Type of operation:</b>		<b>Stamp</b>			
Service <input type="checkbox"/>					
..... <input type="checkbox"/>					
<b>Anti-corrosion check:</b>					
OK <input type="checkbox"/> Not OK* <input type="checkbox"/>					
*See specific page					
Date: _____ Miles (Km): _____		Invoice number: _____		Comments/miscellaneous	
<b>Type of operation:</b>		<b>Stamp</b>			
Service <input type="checkbox"/>					
..... <input type="checkbox"/>					
<b>Anti-corrosion check:</b>					
OK <input type="checkbox"/> Not OK* <input type="checkbox"/>					
*See specific page					
Date: _____ Miles (Km): _____		Invoice number: _____		Comments/miscellaneous	
<b>Type of operation:</b>		<b>Stamp</b>			
Service <input type="checkbox"/>					
..... <input type="checkbox"/>					
<b>Anti-corrosion check:</b>					
OK <input type="checkbox"/> Not OK* <input type="checkbox"/>					
*See specific page					

# ANTICORROSION CHECK (1/5)

If the continuation of the warranty is subject to repair, it is indicated below.

VIN: .....

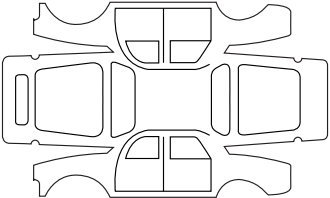
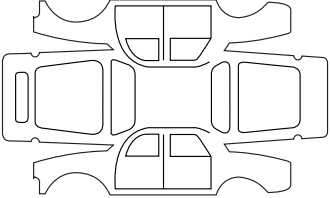
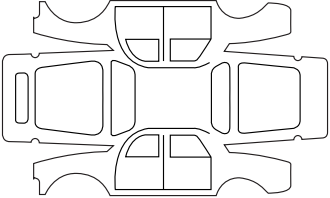
Corrosion repair operation to be carried out:		<b>Stamp</b>
Date of repair:		
Repair to be carried out:		<b>Stamp</b>
Date of repair:		
Repair to be carried out:		<b>Stamp</b>
Date of repair:		

# ANTICORROSION CHECK (2/5)

If the continuation of the warranty is subject to repair, it is indicated below.

VIN: .....

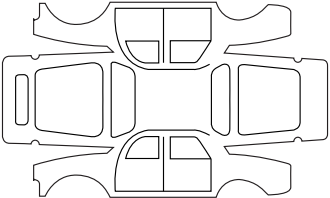
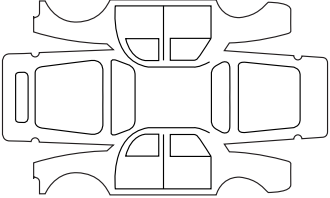
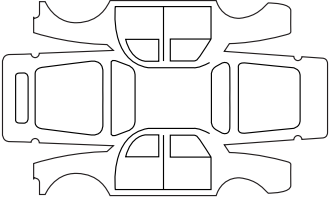
Corrosion repair operation to be carried out:		<b>Stamp</b>
Date of repair:		
Repair to be carried out:		<b>Stamp</b>
Date of repair:		
Repair to be carried out:		<b>Stamp</b>
Date of repair:		

# ANTICORROSION CHECK (3/5)

If the continuation of the warranty is subject to repair, it is indicated below.

**VIN:** .....

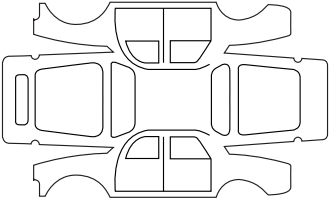
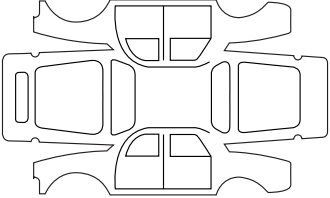
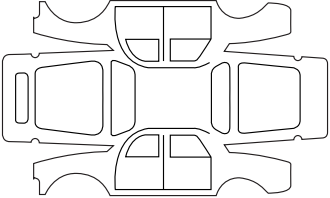
Corrosion repair operation to be carried out:		<b>Stamp</b>
Date of repair:		
Repair to be carried out:		<b>Stamp</b>
Date of repair:		
Repair to be carried out:		<b>Stamp</b>
Date of repair:		

# ANTICORROSION CHECK (4/5)

If the continuation of the warranty is subject to repair, it is indicated below.

**VIN:** .....

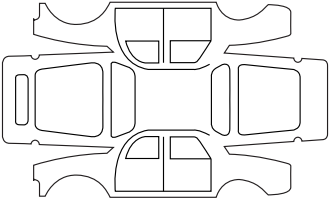
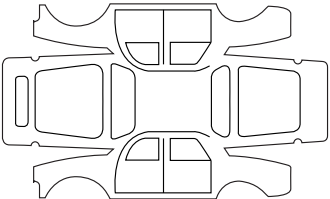
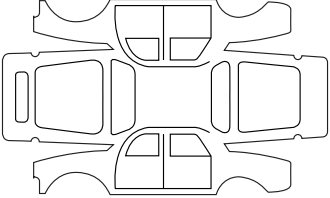
Corrosion repair operation to be carried out:		<b>Stamp</b>
Date of repair:		
Repair to be carried out:		<b>Stamp</b>
Date of repair:		
Repair to be carried out:		<b>Stamp</b>
Date of repair:		

# ANTICORROSION CHECK (5/5)

If the continuation of the warranty is subject to repair, it is indicated below.

VIN: .....

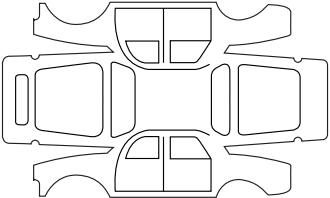
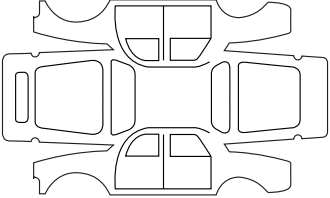
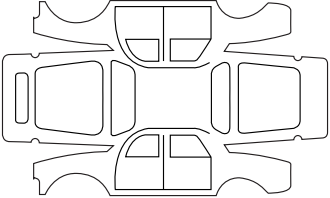
Corrosion repair operation to be carried out:		
Corrosion repair operation to be carried out:		Stamp
Date of repair:		
Repair to be carried out:		
Repair to be carried out:		Stamp
Date of repair:		
Repair to be carried out:		
Repair to be carried out:		Stamp
Date of repair:		





# ALPHABETICAL INDEX (1/6)

**4**  
4 wheel drive (4WD).....2.37 → 2.41

## A

ABS .....2.42 → 2.46  
accessories.....5.50  
accessories socket .....3.21 – 3.22  
additive (reagent).....1.114 → 1.118  
additive tank capacity .....1.114 → 1.118  
adjusting your driving position .....1.22 → 1.27  
advice on antipollution .....2.30  
air bag.....1.28 → 1.34  
air conditioning .....3.2 → 3.14  
air vents .....3.2 → 3.4  
airbag  
    front passenger airbag deactivation.....1.51  
anti-corrosion check .....6.17 → 6.21  
anti-corrosion protection.....4.18  
anti-lock braking system: ABS .....2.42 → 2.46  
antipollution  
    advice .....2.30  
armrest  
    front.....1.19 → 1.21  
armrest .....3.29  
ashtrays .....3.21 – 3.22  
automatic gearbox (use).....2.58 → 2.61, 5.48  
automatic gearbox selector lever.....2.58 → 2.61  
automatic locking of the doors while driving .....1.15

## B

batteries.....5.42  
battery  
    breakdown recovery .....5.37 → 5.39  
battery.....4.16 – 4.17  
battery (remote control).....5.40 – 5.41

blind spot warning signal .....2.69 → 2.72  
blind spot: warning signal .....2.69 → 2.72  
bonnet.....4.2 – 4.3  
brake fluid .....4.10  
bulbs  
    changing .....5.17 → 5.32

## C

capacity of mechanical components.....4.4, 4.16  
card: battery.....5.42 – 5.43  
card: use.....1.5 → 1.11  
catalytic converter.....2.17 – 2.18  
central door locking .....1.12 → 1.14  
changing a bulb .....5.17 → 5.32  
changing a wheel.....5.11 – 5.12  
changing fuel while driving .....2.21 → 2.24  
changing gear .....2.36, 2.58 → 2.61  
child booster seat .....1.35 → 1.37  
child restraint/seat .....1.35 → 1.42, 1.45 – 1.46, 1.49 – 1.50  
child safety.....1.2, 1.9 → 1.11, 1.16 – 1.17, 1.35 → 1.42,  
1.45 – 1.46, 1.49 – 1.50, 3.15 → 3.17  
child seats.....1.35 → 1.42, 1.45 – 1.46, 1.49 – 1.50  
children .....1.5, 1.10 – 1.11, 1.16 – 1.17  
children (safety).....1.5, 1.9, 3.15 → 3.17  
cigar lighter .....3.21 – 3.22  
cleaning:  
    inside the vehicle .....4.21 – 4.22  
clock .....1.95 – 1.96  
closing the doors .....1.12 → 1.14, 1.16 – 1.17  
control instruments ....1.70 → 1.79, 1.95 – 1.96, 1.98 → 1.101  
controls.....1.54 → 1.69, 1.68 – 1.69  
courtesy light .....3.18 – 3.19  
cruise control .....2.52 → 2.57  
cruise control-speed limiter.....2.47 → 2.57

# ALPHABETICAL INDEX (2/6)

## D

dashboard.....	1.54 → 1.69, 1.68 – 1.69
de-icing/de-misting	
windscreen.....	3.5 → 3.8
demisting	
rear screen.....	3.9 → 3.12
windscreen.....	3.9 → 3.12
dimensions .....	6.6
dipstick.....	4.4 – 4.5
doors.....	1.15 → 1.17
doors/tailgate .....	1.5 → 1.7
driver assistance.....	2.73 → 2.78
driver's position .....	1.54 → 1.69, 1.68 – 1.69
driving.....	2.2 → 2.12, 2.17 → 2.20, 2.25 → 2.29, 2.36 → 2.65, 2.73 → 2.78
driving aids .....	2.73 → 2.78
driving position	
settings .....	1.22 → 1.27
driving recommendations .....	2.25 → 2.29

## E

ECO driving .....	1.70 → 1.75, 2.25 → 2.29
ECO mode.....	2.25 → 2.29
electric beam height adjustment.....	1.102 – 1.103
electric windows .....	3.15 → 3.17
electronic stability control: ESC.....	2.42 → 2.46
emergency brake assist.....	2.42 → 2.46
emergency braking.....	2.42 → 2.46
emergency call .....	2.79 → 2.81
emergency key .....	1.5 → 1.7
emergency spare wheel .....	5.3 → 5.5, 5.13 → 5.16
engine	
technical specifications.....	6.7 – 6.8
engine coolant.....	4.11
engine identification plates.....	6.4 – 6.5
engine immobiliser (switch).....	2.2

engine oil .....	4.4 – 4.5
engine oil grade .....	4.6 → 4.9
engine oil level.....	4.6 → 4.9
engine specifications .....	6.7 – 6.8
engine standby .....	2.13 → 2.16
engine start/stop button.....	2.7 → 2.12
environment.....	2.31
ESC: electronic stability control.....	2.42 → 2.46
external temperature .....	1.96

## F

### faults

operating faults .....	5.51 → 5.59
filling with reagent.....	1.114 → 1.118
filter	
air filter .....	4.13
diesel filter.....	1.111, 4.13
particle filter .....	2.18, 2.20
passenger compartment filter .....	4.13
filter.....	4.13
fitting a radio.....	5.49
fittings .....	3.25 → 3.29
flap	
fuel flap .....	1.108 → 1.113
fog lights .....	1.99
front passenger air bag deactivation .....	1.51
front seat adjustment.....	1.19 → 1.21
front seats	
adjustment .....	1.18 → 1.21
fuel	
advice on fuel.....	2.25 → 2.29
consumption .....	2.25 → 2.29
filling.....	1.108 → 1.113
quality .....	1.108 → 1.113, 6.7 – 6.8
fuel consumption .....	3.13
fuel economy .....	2.25 → 2.29

## ALPHABETICAL INDEX (3/6)

fuel filler cap .....	1.108 → 1.113
fuel priming bulb .....	1.111
fuel tank .....	1.108 → 1.113
fuel tank capacity .....	1.108 → 1.113
fuses .....	5.33 → 5.36

### G

gear lever .....	2.36
glove box .....	3.28
grab handle .....	3.20

### H

handbrake .....	2.36
hands-free telephone integrated control .....	3.42 → 3.44
«hands-free» card: battery .....	5.42 – 5.43
«hands-free» card: use .....	1.8 → 1.11
hazard warning lights signal .....	1.97
headlight beam adjustment .....	1.102 – 1.103
headlight flashers .....	1.97
headrest .....	1.18, 3.23 – 3.24
heated seats .....	1.19 → 1.21
heated steering wheel .....	1.91
heated windscreen .....	3.9 → 3.12
heating and air conditioning system .....	3.2 → 3.13
heating system .....	3.2 → 3.14
Hill Start Assist .....	2.42 → 2.46
horn .....	1.97
hubcap tool .....	5.2

### I

ignition switch .....	2.2
indicator lights .....	5.28
indicators .....	1.97, 5.17 → 5.19
indicators:	
direction indicators .....	1.97
instrument panel .....	1.78 – 1.79

instrument panel .....	1.70 → 1.90
instrument panel messages .....	1.78 → 1.90
interior trim	
maintenance .....	4.21 – 4.22
Isofix .....	1.49 – 1.50

### J

jack .....	5.2, 5.11 – 5.12
jets .....	1.106

### K

keys .....	1.2 – 1.3
------------	-----------

### L

levels .....	4.4 – 4.5, 4.10 → 4.12
levels:	
coolant .....	4.11
lifting the vehicle	
changing a wheel .....	5.2 → 5.5, 5.10 → 5.12
lighting:	
exterior .....	1.6, 1.98 → 1.101, 5.17 → 5.28
interior .....	3.18 – 3.19, 5.29 → 5.32
lights	
additional .....	5.20 – 5.21
adjustment .....	1.102 – 1.103
lights .....	1.98 → 1.103
lights:	
adjusting .....	1.102 – 1.103
brake lights .....	5.22
daytime running lights .....	5.17
dipped beam headlights .....	1.98, 5.17 → 5.19
direction indicators .....	1.97, 5.17 → 5.19
fog lights .....	1.99, 5.20 – 5.21
hazard warning .....	1.97
main beam headlights .....	1.98, 5.17 → 5.19

# ALPHABETICAL INDEX (4/6)

reversing lights.....	5.22
side lights.....	1.98, 5.17 → 5.19
locking the doors.....	1.4 → 1.11
LPG.....	1.78 – 1.79, 1.82 – 1.83, 1.112 – 1.113, 2.4 → 2.7, 2.21 → 2.24, 5.34 → 5.36

## M

maintenance.....	2.30
maintenance:	
bodywork.....	4.18 → 4.20
interior trim.....	4.21 – 4.22
mechanical.....	4.4 – 4.5, 4.10, 4.16, 6.11 → 6.16
map reading lights.....	3.18 – 3.19
methods of restraint in addition to the front seat belts.....	1.28 → 1.32, 1.34
methods of restraint in addition to the seat belts...1.28 → 1.32	
mirrors.....	3.20
multimedia equipment.....	3.42 → 3.44
multi-view camera.....	2.73 → 2.78

## N

navigation.....	3.42 → 3.44
navigation system.....	3.42 → 3.44

## O

oil change.....	4.6 → 4.9
opening the doors.....	1.12 → 1.14, 1.16 – 1.17
operating faults.....	5.51 → 5.59
overspeed buzzer.....	1.76 – 1.77

## P

paint	
maintenance.....	4.18 → 4.20
reference.....	6.2
parking distance control.....	2.62 → 2.68
power-assisted steering.....	1.91

practical advice.....	1.111, 3.36, 5.2 → 5.5, 5.10 → 5.39, 5.44 → 5.49
pretensioners.....	1.28 → 1.32
puncture.....	5.3 → 5.5, 5.11 – 5.12

## Q

QR Code.....	6.3
quality	
fuel.....	1.108 → 1.113

## R

radio	
fitting a radio.....	5.49
radio.....	3.42 → 3.44
radio frequency remote control/key	
use.....	1.2
reagent (tank).....	1.114 → 1.118
reagent quality.....	1.114 → 1.118
reagent tank.....	1.114 → 1.118
reagent tank cap.....	1.114 → 1.118
reagent tank capacity.....	1.114 → 1.118
rear bench seat.....	3.30 → 3.32
rear parcel shelf.....	3.37
rear screen de-icing/demisting.....	3.5 → 3.8
rear seats	
functions.....	3.30 → 3.32
rear view camera.....	2.66 → 2.68
rear view mirrors.....	1.93 – 1.94
remote control door locking	
batteries.....	5.40 – 5.41
remote control door locking unit.....	1.2 → 1.4
remote engine start-up.....	1.2 – 1.3
replacement parts.....	6.10
reverse gear	
selecting.....	2.36
reversing sensor.....	2.62 → 2.65

## ALPHABETICAL INDEX (5/6)

roof bars .....	3.38 → 3.41
roof rack	
roof bars .....	3.38 → 3.41
running in .....	2.2

### S

SCR: selective catalytic reduction .....	1.114 → 1.118
screens	
multimedia screen .....	2.73 → 2.78
seat belts .....	1.22 → 1.34
seats	
heated seat .....	3.30 → 3.32
service sheets .....	6.11 → 6.16
signals and lights .....	1.98 → 1.101
socket	
multimedia socket(s) .....	3.42 → 3.44
speakers	
location .....	5.49
special features of diesel versions .....	2.19 – 2.20
special features of LPG versions .....	2.21 → 2.24
special features of petrol vehicles .....	2.17 – 2.18
speed limiter .....	2.47 → 2.51
spoiler .....	3.41
starting .....	2.3 → 2.6
starting the engine .....	2.2 → 2.16
steering wheel	
adjustment .....	1.91 – 1.92
Stop & Start .....	2.13 → 2.16
Stop & Start function .....	2.13 → 2.16
storage compartment .....	3.25 → 3.29
storage compartments .....	3.25 → 3.29
sun visor .....	3.20
switching on the vehicle ignition .....	2.9

### T

tailgate .....	3.33 → 3.35
tank	
Brake fluid .....	4.10
Coolant .....	4.11
technical specifications .....	6.2, 6.7 → 6.10
telephone .....	3.42 → 3.44
temperature regulation .....	3.9 → 3.14
towing	
breakdown .....	5.45 → 5.48
towing equipment .....	3.36
towing .....	6.9
towing a caravan .....	6.9
towing hitch .....	5.45 → 5.48
towing rings .....	3.34 – 3.35
towing weights .....	6.9
traction control .....	2.42 → 2.46
transporting children .....	1.35 → 1.42, 1.45 – 1.46, 1.49 – 1.50
transporting objects	
in the luggage compartment .....	3.34 – 3.35
trims .....	5.10
trip computer and warning system .....	1.78 → 1.90
tyre inflation kit .....	5.6 → 5.9
tyre pressure .....	2.32 → 2.35, 4.14 – 4.15, 5.14
tyre pressure loss warning .....	2.32 → 2.35
tyre pressures .....	4.14 – 4.15
tyres .....	2.32 → 2.35, 4.14 – 4.15, 5.13 → 5.16

### U

unlocking the doors .....	1.12 → 1.14
---------------------------	-------------

### V

variable power-assisted steering .....	1.91
vehicle identification .....	6.2
vehicle identification plates .....	6.2

## ALPHABETICAL INDEX (6/6)

ventilation	
air conditioning.....	3.2 → 3.4
heating and air conditioning system .....	3.5 → 3.8
ventilation .....	3.9 → 3.14

### W

warning buzzer .....	1.99
warning lights.....	1.70 → 1.90
washing .....	4.18 → 4.20
weight .....	6.9
weights .....	6.9
wheelbrace .....	5.2
windows.....	3.15 → 3.17
windscreen de-icing/demisting .....	3.9 → 3.12
windscreen washer.....	1.104 → 1.107
wiper blades .....	1.104 → 1.107, 5.44
wipers	
blades .....	5.44
wipers .....	1.104 → 1.107