

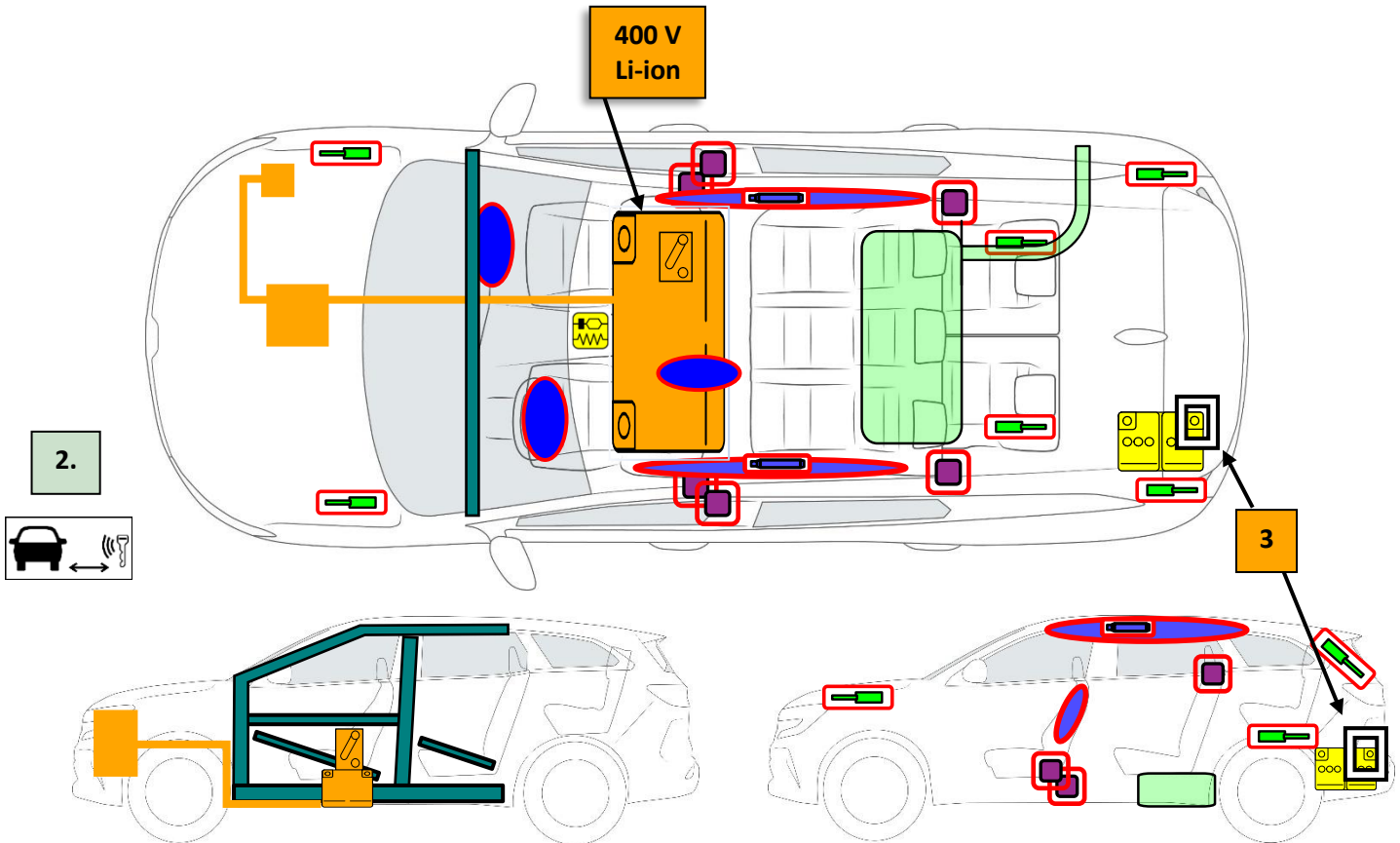

RENAULT ESPACE E-Tech Full Hybrid (2023 -)



	Airbag		Gasgenerator		Gurtstraffer		SRS Steuergerät		
			Gasdruckdämpfer / vorgespannte Feder		Karosserie-Verstärkung				
	Niedervolt-Batterie				Treibstofftank				
	Hochspannungsbatterie		Hochspannungskabel		Hochvolt-Trennstelle				

Confidential C

In Zusammenarbeit mit
REPUBLIQUE FRANÇAISE

MINISTÈRE DE L'INTÉRIEUR

Interne Bezeichnung

RS-RHN HEV-2023

Datum der Version

03/05/2023

Version

1

Seite

1 / 4

1. Identifizierung/Erkennung

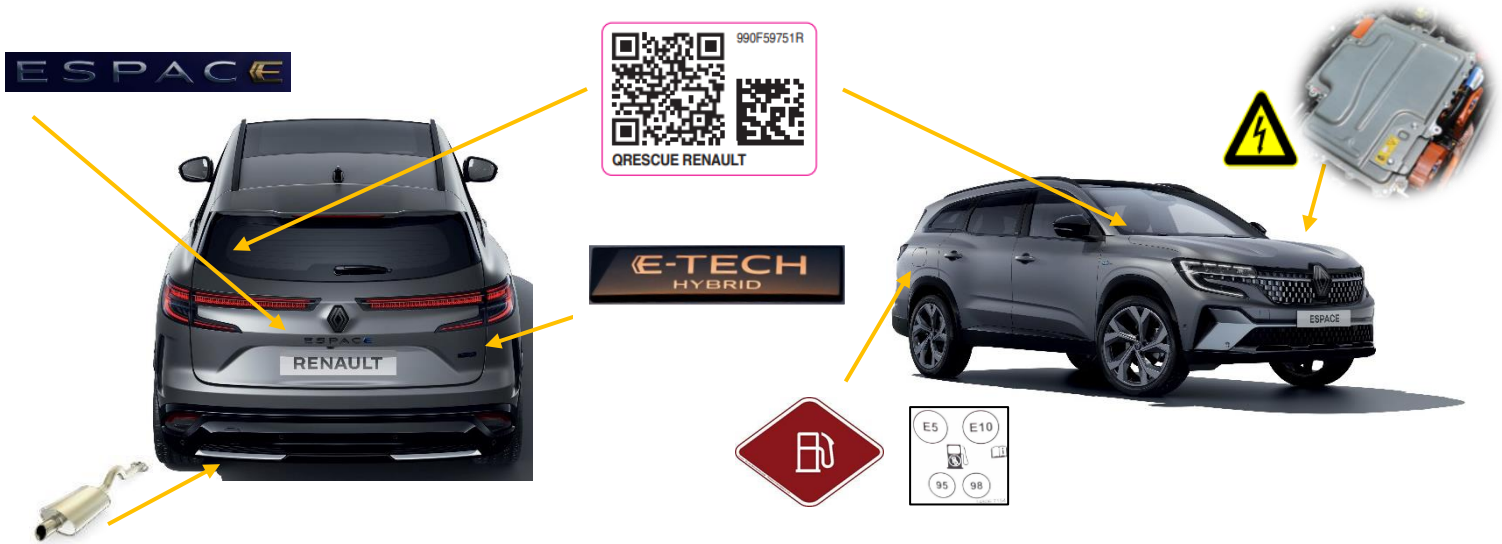

2. Immobilisieren/Stabilisieren/Anheben

Motorstillstand



Hier nicht anheben/aufsetzen!



Bereich mit orangefarbenen Kabeln

3. Direkte Gefahren ausschalten/Sicherheitsbestimmungen

12 Volts Battery

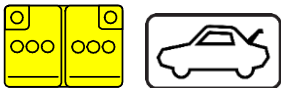

Bei Airbagauslösung schaltet sich die 12V-Batterie automatisch aus

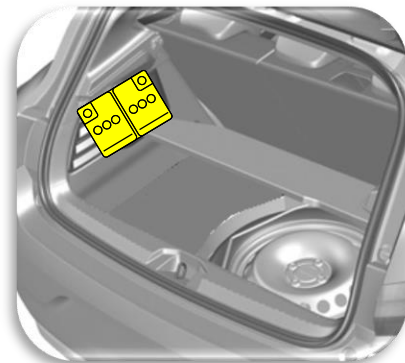

400 V-Batterie



Nur im Rettungs-/Bergungsfalle! :

Abschalten der 400 V-Batterie: Service-Plug entfernen

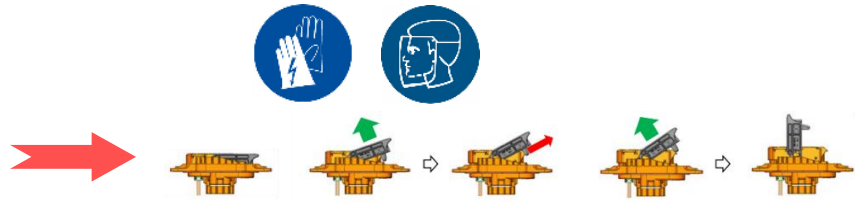
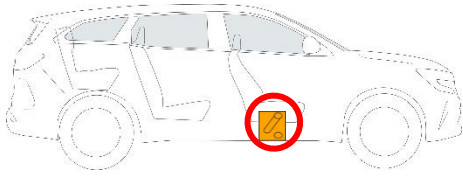

4. Zugang zu den Insassen



Lenksäule :
Hohl, teilbar hinter

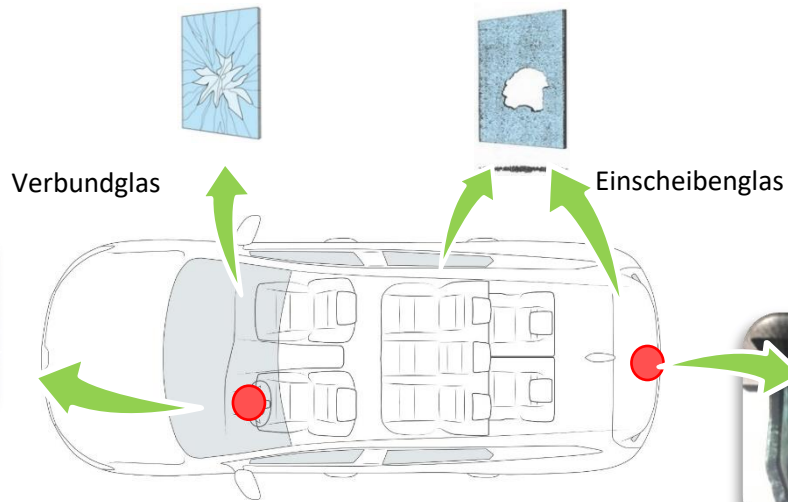

MÖGLICHE SITZNEIGUNG

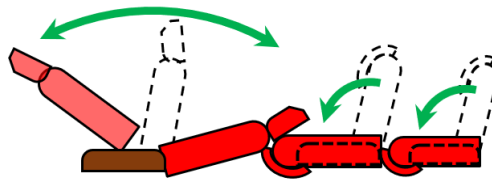

HOCHELASTISCHER STAHL

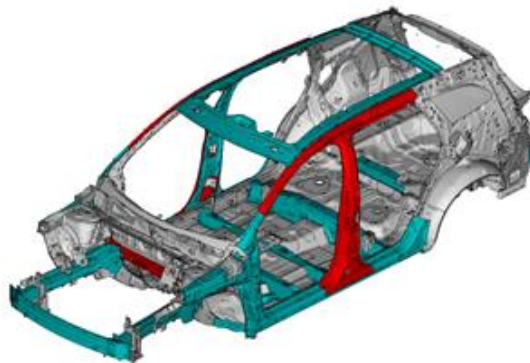

5. Gespeicherte Energie/Flüssigkeiten/Gase/Feststoffe

	Lithium-Ion	1,75 kW.h	400 V
---	-------------	-----------	-------

	E5 E10	55 L
--	--------	------

6. Im Brandfall

Auslöschen einer Traktionsbatterieleuchte



GASDRUCKDÄMPFER



Explosionsgefahr durch Gasdruckdämpfer!

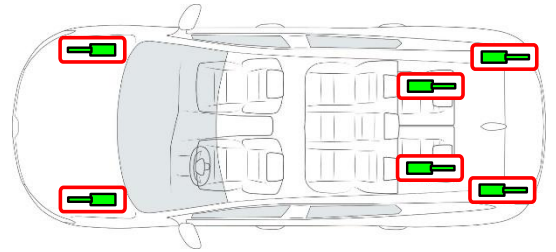

7. Im Falle des Untertauchens







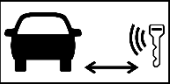

Kein elektrisches Risiko

8. Abschleppen/Transport/Lagerung



10. Erläuterung der verwendeten Piktogramme

	Elektrohybridfahrzeug mit flüssigen Kraftstoffen der Kl. 2				
	Smart-Schlüssel entfernen		Motorhaube		Kofferraum
	Entzündbar		Gesundheitsschädlich		Umweltgefährlich