



RENAULT

# Renault 5 E-Tech 100% Elektrický



(2024 - )

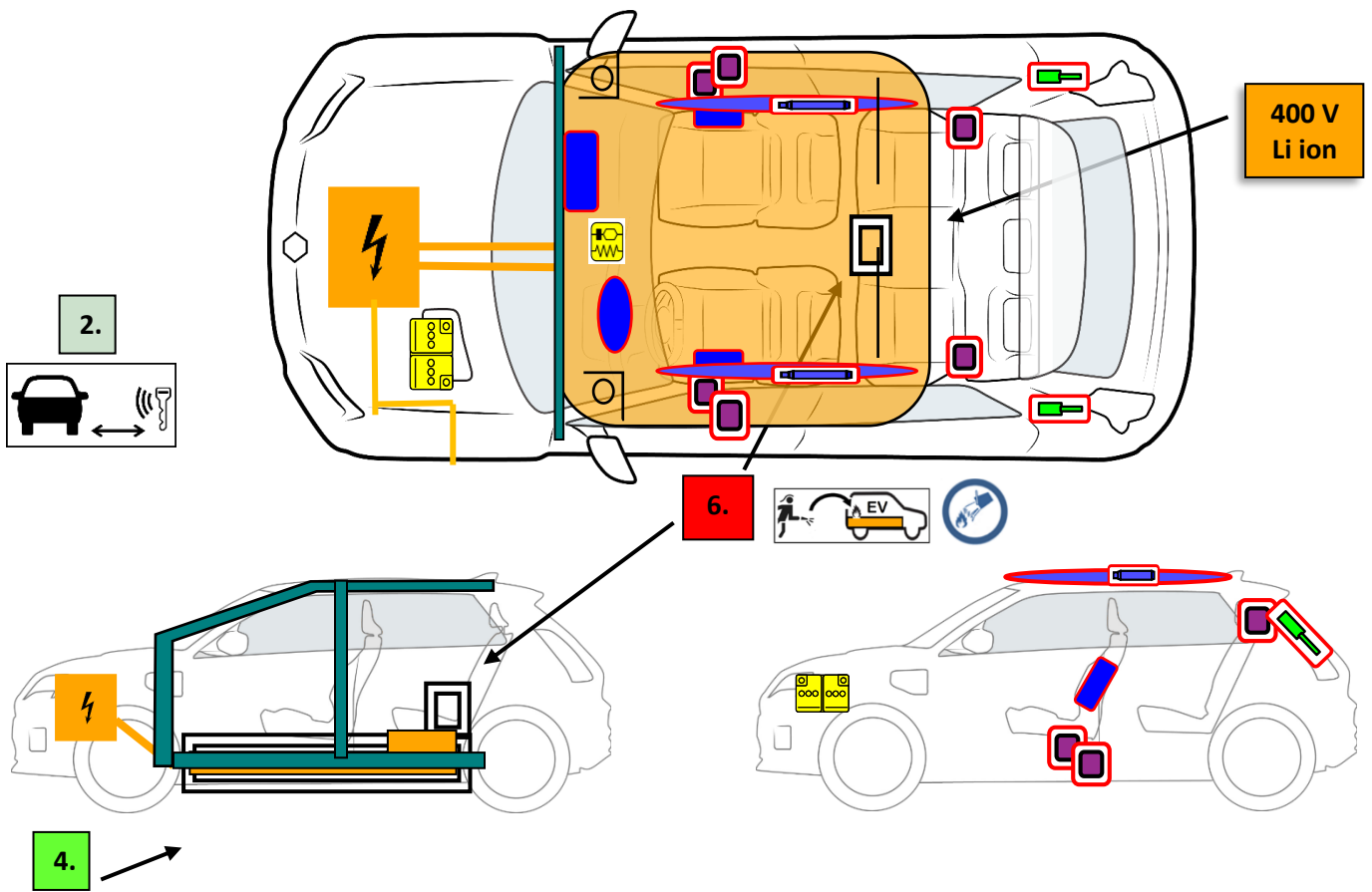

	Airbag		Gasgenerator		Gurtstraffer		SRS Steuergerät
	Niedervolt-Batterie		Gasdruckdämpfer / vorgespannte Feder		Karosserie-Verstärkung		Bereich Bedarf besonderer Aufmerksamkeit
	Hochspannungsbat-terie		Hochspannungs-kabel				Hochspannungs-komponente

En concertation avec



MINISTÈRE DE L'INTÉRIEUR

Référence interne

Date

Version

Page

RS-B1316-2024

01/08/2024

1

1 / 4

## 1. Identifizierung/Erkennung





## 2. Immobilisieren/Stabilisieren/Anheben

### Motorstillstand

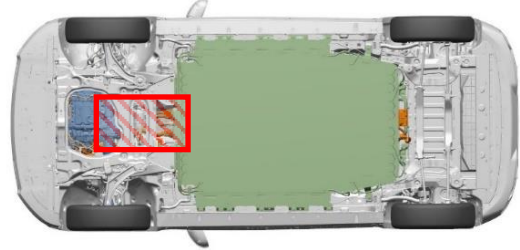

### Hier nicht anheben/aufsetzen



 Bereich mit orangefarbenen Kabeln

## 3. Direkte Gefahren ausschalten/Sicherheitsbestimmungen

### 12 Volts battery

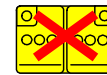
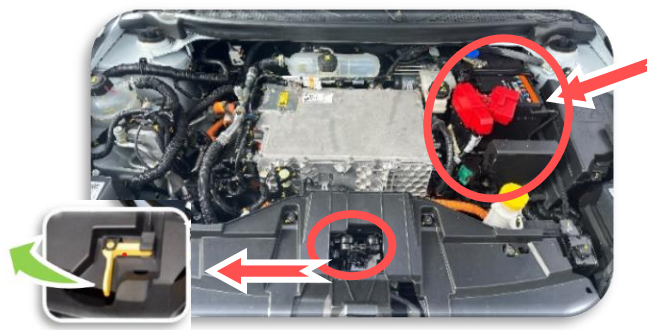
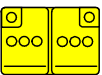

### 400 Volts Battery



Enhver airbag eller selestrammer, der udløses garanterer automatisk frakobling af 400V-batteriet: Fravær af afbrydelsessystem => ingen handling anmodet om



## 4. Zugang zu den Insassen



Hohle Lenksäule,  
abnehmbar hinter  
Dem Lenkrad

Verbundglas



Einscheibenglas

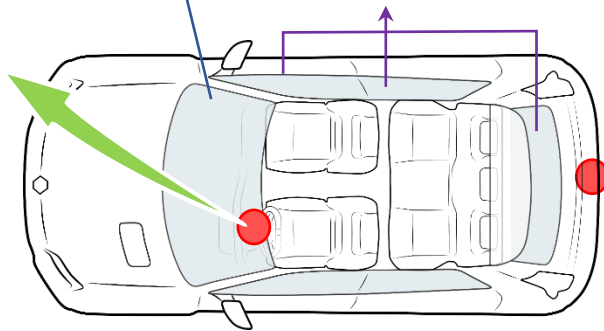

Interner Knopf zum manuellen Öffnen

## HOCHELASTISCHER STAHL

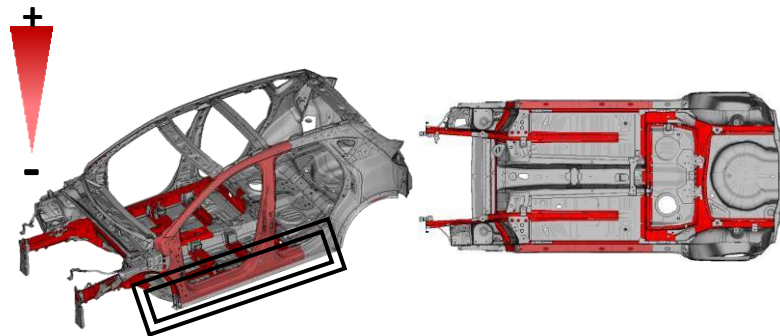

## MÖGLICHE SITZNEIGUNG

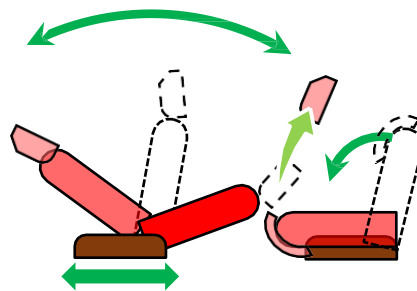

## 5. Gespeicherte Energie/Flüssigkeiten/Gase/Feststoffe

	Lithium-ion	40/52 kW.h	400 V	Casing Aluminium
---	-------------	------------	-------	------------------

## 6. Im Brandfall

### Auslöschen einer Traktionsbatterieleuchte

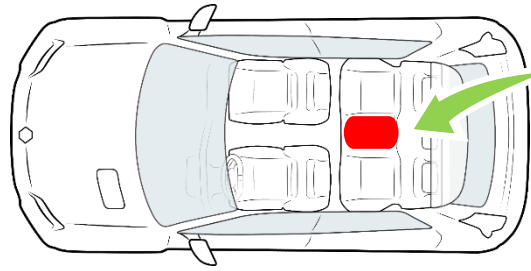

Spezial-Feuerlöschsystem für die 400 V Batterie

### GASDRUCKDÄMPFER



Keine Explosionsgefahr durch Gasdruckklappe

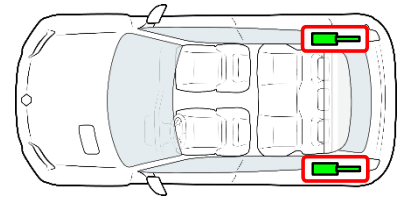

## 7. Im Falle des Untertauchens



Kein elektrisches Risiko

Nachdem Sie das Fahrzeug aus dem Wasser genommen haben : Abschalten der 400 V-Batterie: Service-Plug entfernen

## 8. Abscheppen / transport / lagerung



## 10. Erläuterung der verwendeten Piktogramme

Elektrofahrzeug		Gezielter Zugriff auf die brennende 400-V- Batterie		
Smart-Schlüssel entfernen		Kofferraum		IR-Wärmebildkamera benutzen
Entzündbar		Gesundheitsschädlich		Umweltgefährlich
Schutzhandschuhe 	Gesichtsschutz 	Atemschutzausrüstung 	Mit Wasser löschen 	Nicht aufbrechen! Nicht öffnen! 