

# RENAULT CLIO 5 (LPG)

Alle Typen  
(2020 - )

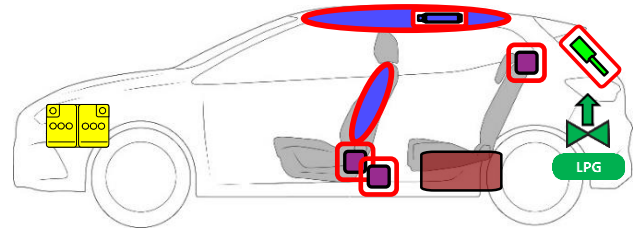
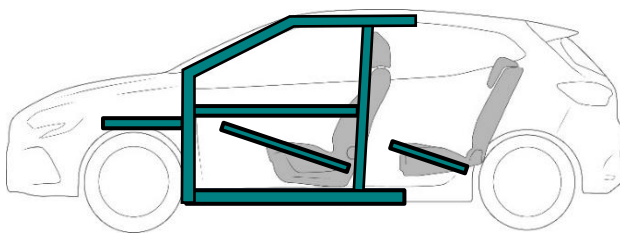
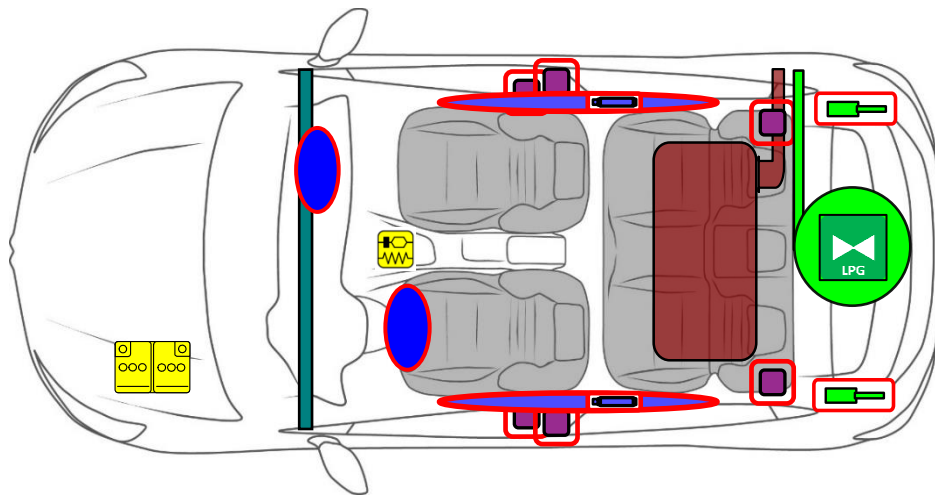
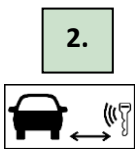

	Airbag		Gasgenerator		Gurtstraffer		SRS Steuergerät		
			Gasdruckdämpfer / vorgespannte Feder		Karosserie-Verstärkung				
	Niedervolt-Batterie				Treibstofftank		Gastank		Sicherheitsventil

# 1. Identifizierung/Erkennung



# 2. Immobilisieren/Stabilisieren/Anheben

## Immobilisieren

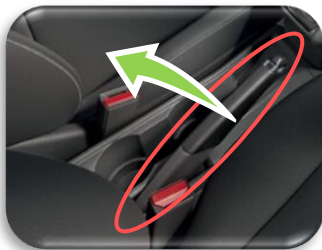

## Motorstillstand



# 3. Direkte Gefahren ausschalten/Sicherheitsbestimmungen

## 12 V-Batterie

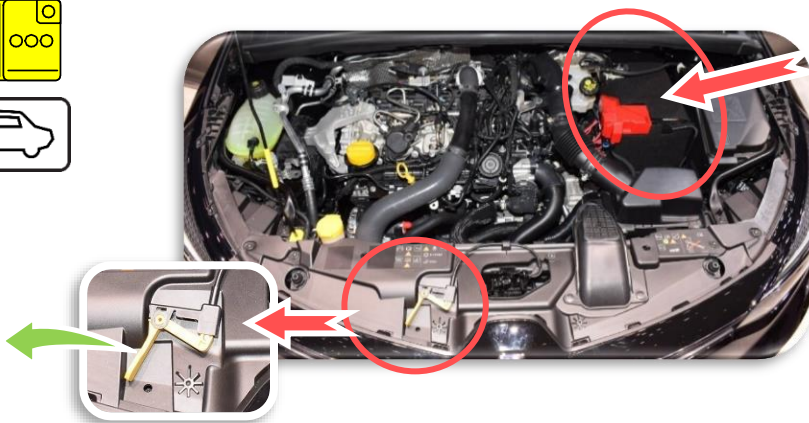
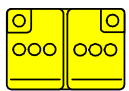

- 1 - Motorstillstand
- 2 - Minuspol (-) abklemmen

Interne Bezeichnung	Aktualisierungsdatum	Version	Seite
RS-BJA LPG-2020- ph1&2	06/03/2023	2	2 / 4

## 4. Zugang zu den Insassen

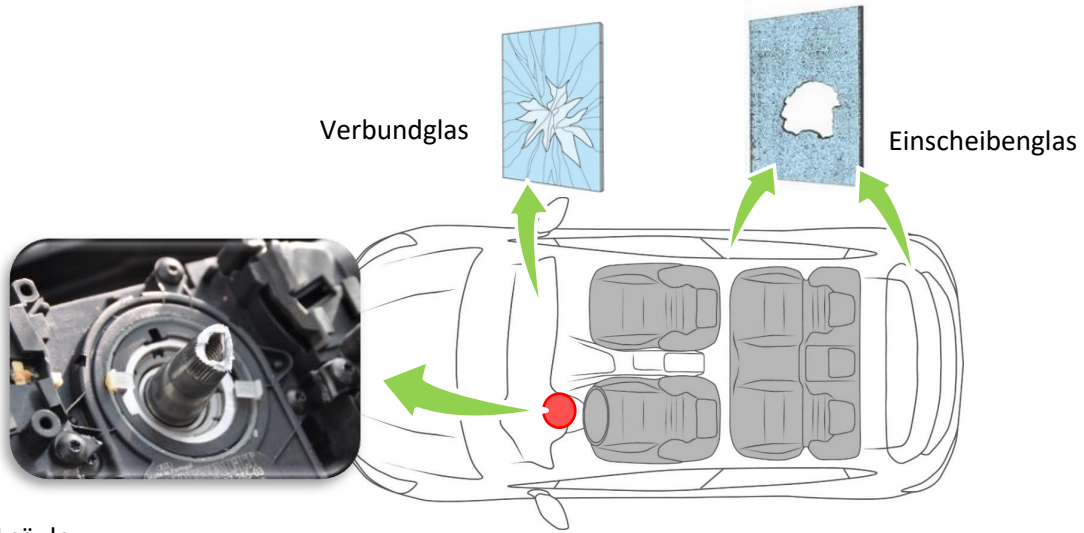





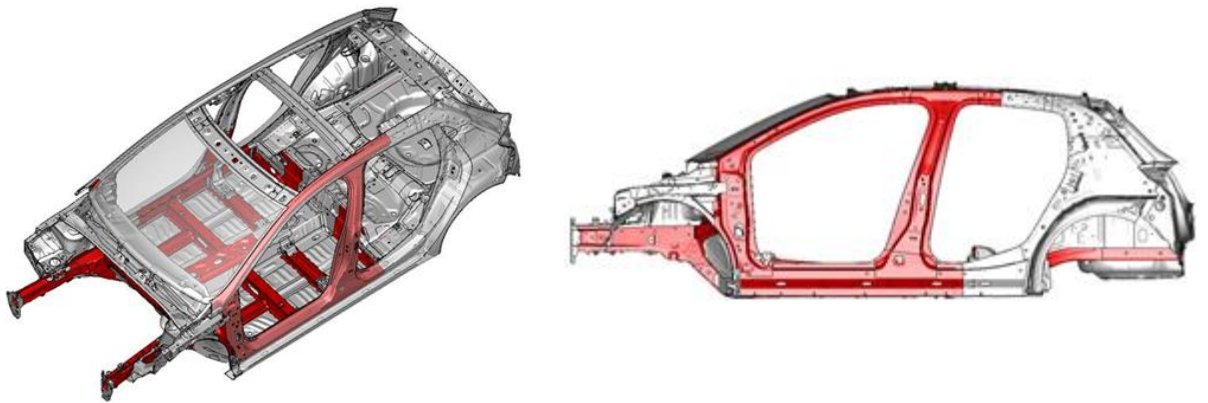

Lenksäule :  
Hohl, teilbar hinter

## HOCHELASTISCHER STAHL



## 5. Gespeicherte Energie/Flüssigkeiten/Gase/Feststoffe

	39 L	  
	32 L	

## 6. Im Brandfall

### FAHRZEUG MIT LPG-ANTRIEB

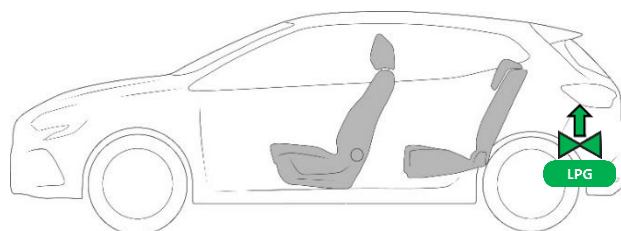

In Zusammenarbeit mit



MINISTÈRE DE L'INTÉRIEUR

Interne Bezeichnung

Aktualisierungsdatum

Version

Seite

RS-BJA LPG-2020- ph1&2

06/03/2023

2

3 / 4

## GASDRUCKDÄMPFER



Explosionsgefahr durch Gasdruckdämpfer!

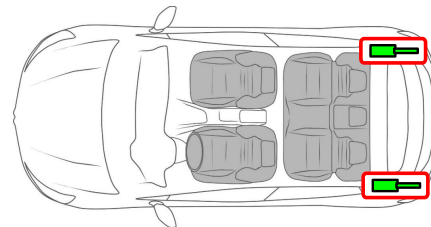

### 10. Erläuterung der verwendeten Piktogramme

	Fahrzeug mit flüssigen Kraftstoffen der Kl. 2		Fahrzeug mit LPG-Antrieb
	Smart-Schlüssel entfernen		Motorhaube
	Entzündbar		Gesundheitsschädlich
	Kofferraum		Umweltgefährlich