

NEW
**RENAULT ARKANA
E-TECH FULL HYBRID**
145 HP



3rd April 2024



hybrid by nature

Designed to turn heads, new Renault Arkana E-Tech full hybrid reinvents the sports SUV. With a streamlined silhouette, raised ground clearance and restyled grille, it successfully combines a dynamic shape with a spacious interior enhanced by a large boot.



Discover the iconic Sport-Chic version, esprit Alpine, and enjoy responsive driving with the E-Tech full hybrid 145hp engine.

sports SUV

**3 seats
at the rear**

**up to
480 litres
of boot volume**

**E-Tech full
hybrid 145 hp
engine**

**up to
620 miles
of range⁽¹⁾**

**up to 18 advanced
driver-assistance
systems⁽²⁾**

(1) with a full tank of petrol according to WLTP data.
(2) depending on version.

interactive menu

01. design

02. driving pleasure

03. interior experience

04. multimedia

05. interior space

**06. advanced driver-
assistance systems**

07. customisation

download the PDF



equipment and engines

sportiness embodied

With a completely restyled grille that incorporates the new Renault emblem, the front end adds to the vehicle's design. At the rear, the black twin exhaust and wide spoiler emphasise its dynamic character. In the esprit Alpine and techno version, the emblematic F1® blade oozes sportiness.



UK spec may vary

The new glossy black chrome-finish grille with unstructured diamonds creates a unique personality.



The rear end does not go unnoticed with its translucent smoky lights, new dark chrome Renault emblem and black Arkana marking.



esprit Alpine badge on the front wings and robust look with its new 19" wheels.*



The interior has an elegant and sporty atmosphere thanks to upholstery enhanced with blue top-stitching. The steering wheel comprises red, white and blue stitching. The Alpine logo - a sign of exclusiveness - embellishes the front seats.



special upholstery in biobased textured coated fabric / suedette on esprit Alpine version*



heated steering wheel covered in perforated textured coated fabric on esprit Alpine version*

*esprit Alpine

[build yours →](#)

02. driving pleasure

E-Tech full hybrid 145hp

E-Tech
full hybrid
145 hp

up to
60.1 mpg
(WLTP combined)⁽¹⁾

up to
620 miles
of driving range⁽²⁾

from
4.7 l/100 km
fuel consumption⁽³⁾

from
105 g/km
CO₂ emissions⁽¹⁾



The E-Tech full hybrid 145 hp makes the car a pleasure to drive. As it is always started in electric mode, acceleration is crisp and dynamic. In town or on the open road, enjoy quiet, responsiveness and agility.

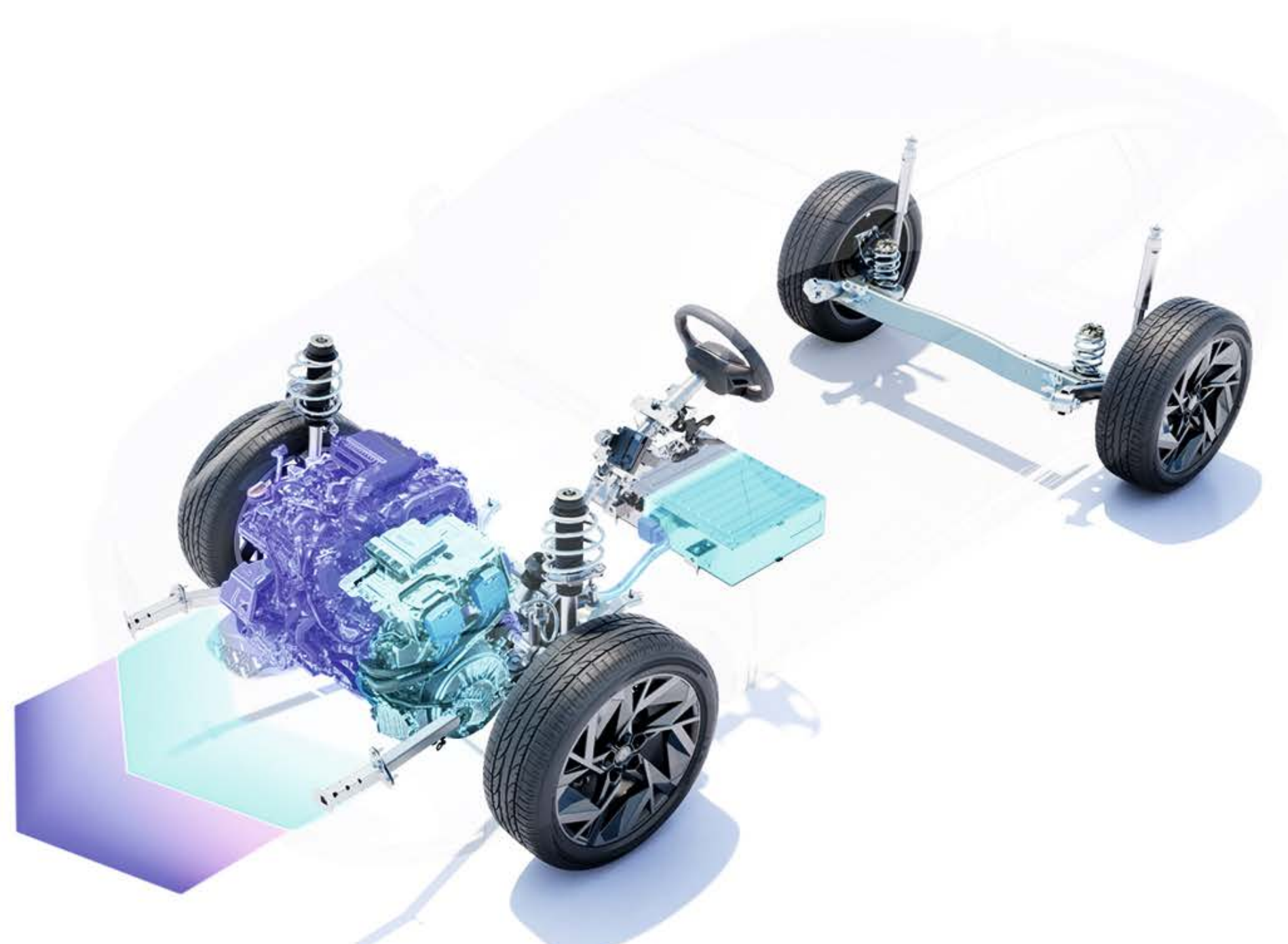

E-Tech full hybrid 145 hp engine

When in EV drive with minimal noise, while automatically charging the battery when decelerating or braking. No need to plug your vehicle into a power outlet.

| | E-Tech full hybrid 145 hp |
|---|---|
| technology | 1230V battery + 2 electric engines + 1 internal combustion engine |
| fuel consumption ⁽³⁾ | from 4.7 l/100 km |
| CO ₂ emissions ⁽³⁾ | from 105 g/km |
| energy recovery via deceleration and braking | yes |
| management of energy recovery level | yes |
| electric assistance to the internal combustion engine | yes |

(1) for an E-Tech full hybrid engine according to WLTC City data / UTAC & IDIADA source / November 2021.

(2) with a full tank of petrol according to WLTP data.

(3) values from 4.7 l/100 km of fuel consumption and from 105 g/km of CO₂ emissions, according to WLTP data / UTAC source / November 2021.

build yours →

03. interior experience

immersive pleasure

"Premium-touch" materials, heated driver's seat and Multi-sense technology offers you three driving modes for a personalised experience.



model shown esprit Alpine
e-shifter gear lever not available in UK

The slate finish of the dashboard and door panels is elegant and adds to the cockpit's modern look.*



*esprit Alpine

build yours →

intuitive connectivity

The easy link multimedia system and its 9.3" central touch screen* facilitate access to navigation, widgets and your customised profile. Keep essential driving information in your direct view by displaying it on the 10" configurable digital instrument panel.*



Access your applications, playlists, contacts and favourites directly on the central screen thanks to smartphone mirroring. The wireless charger always ensures an optimal level of independence.*



With the My Renault application, manage your vehicle remotely and easily through your smartphone: connected services, location of the vehicle, service history, service reminders and garage appointment bookings.

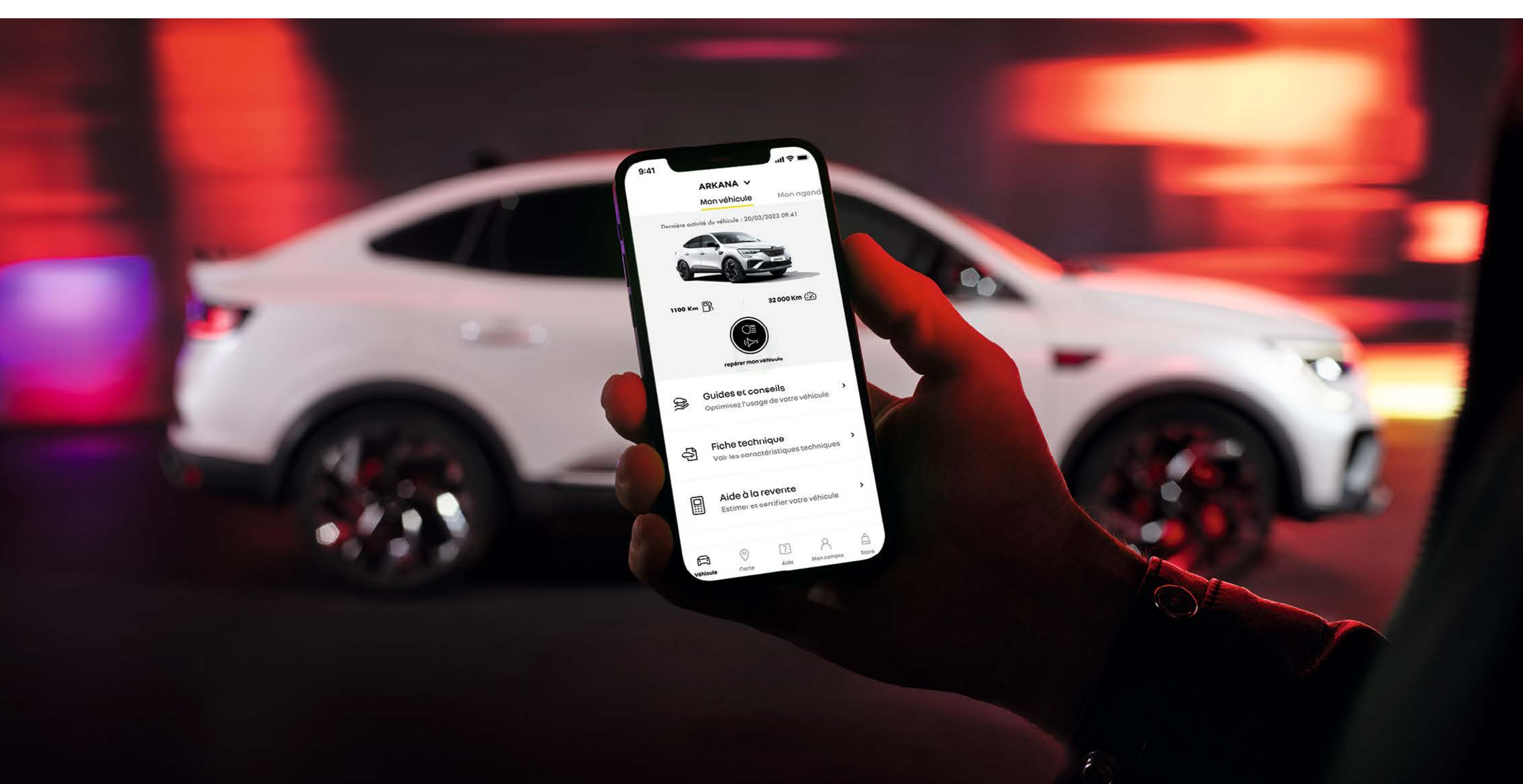

*from techno

build yours →

generous interior space

The sportiness of the lines complements the generous interior and large boot of up to 480 litres.



The carefully designed rear space comprises three seats and 21 cm of knee room.

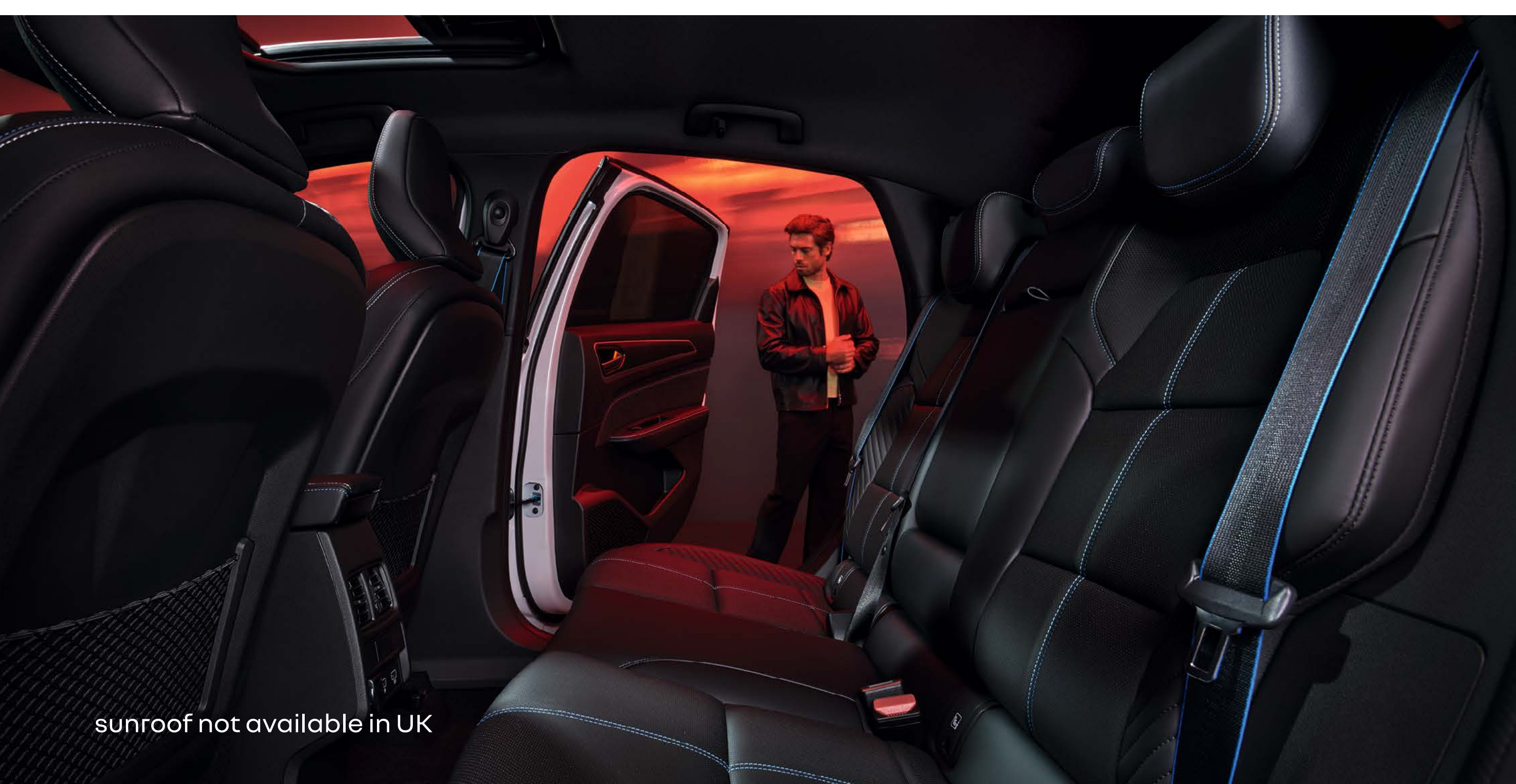

sunroof not available in UK

In the low position, the height-adjustable floor maximises the loading capacity of 1,263 litres; in the high position, it facilitates the loading of heavy objects. A configuration that also gives you a completely flat surface, once the 1/3-2/3 rear bench seatbacks are folded down.

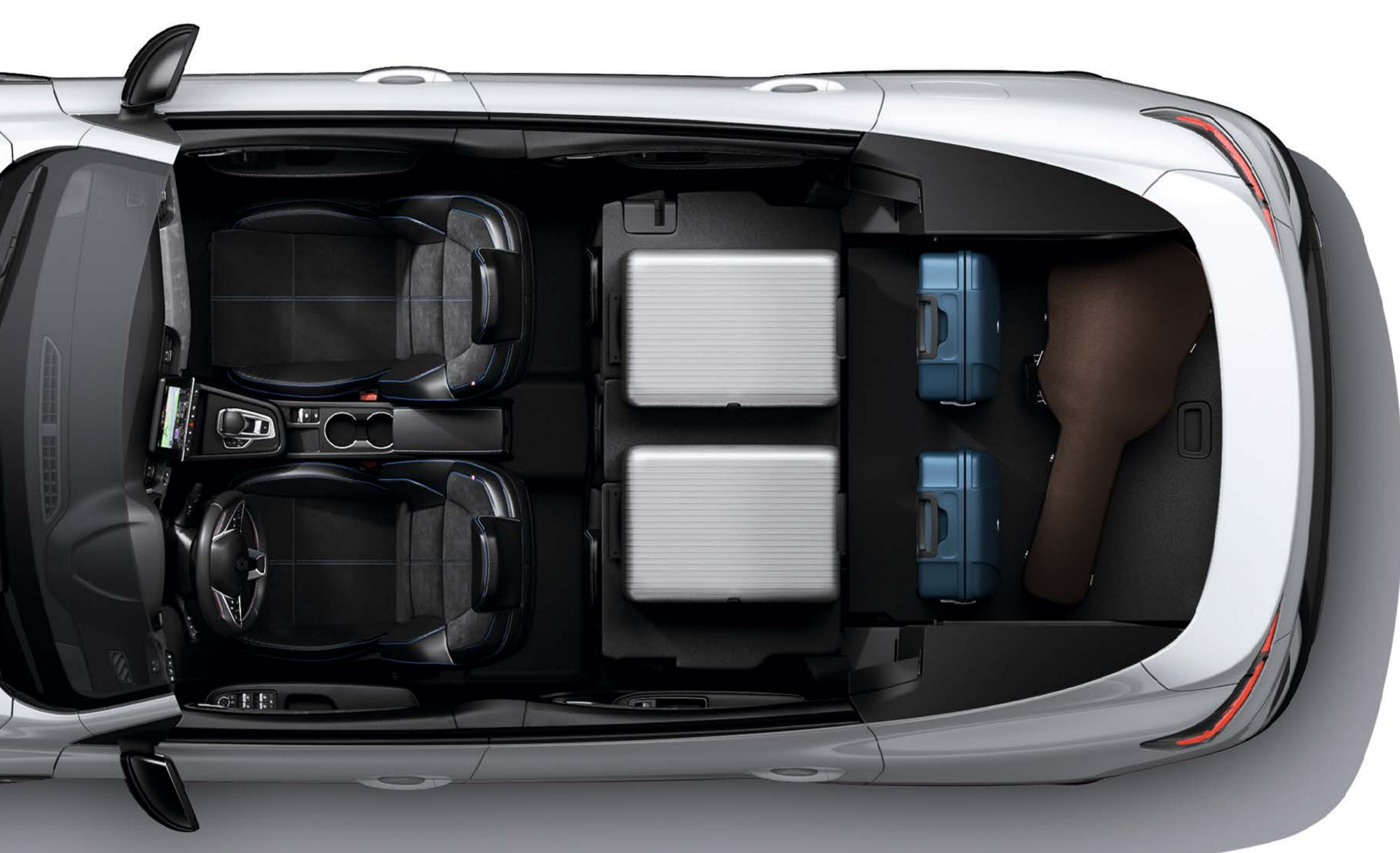

e-shifter gears are not available on UK spec

[build yours →](#)

06. advanced driver-assistance systems



up to 18 advanced driver-assistance systems

As part of the human first program, new Renault Arkana E-Tech full hybrid offers up to 18 advanced driver-assistance systems.

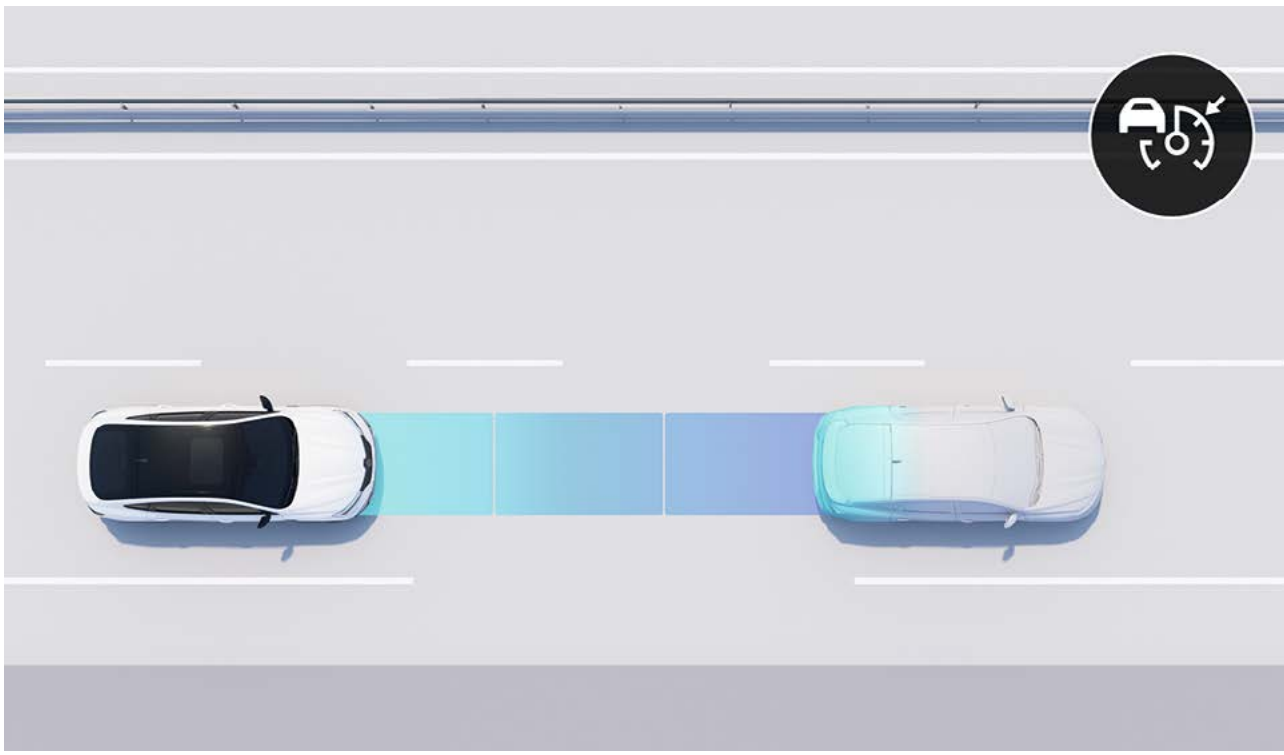

active driver assist
The adaptive cruise control regulates your speed by taking the road environment into account, maintains safe distances and ensures you remain in lane. When traffic slows down, the vehicle stops and restarts automatically.

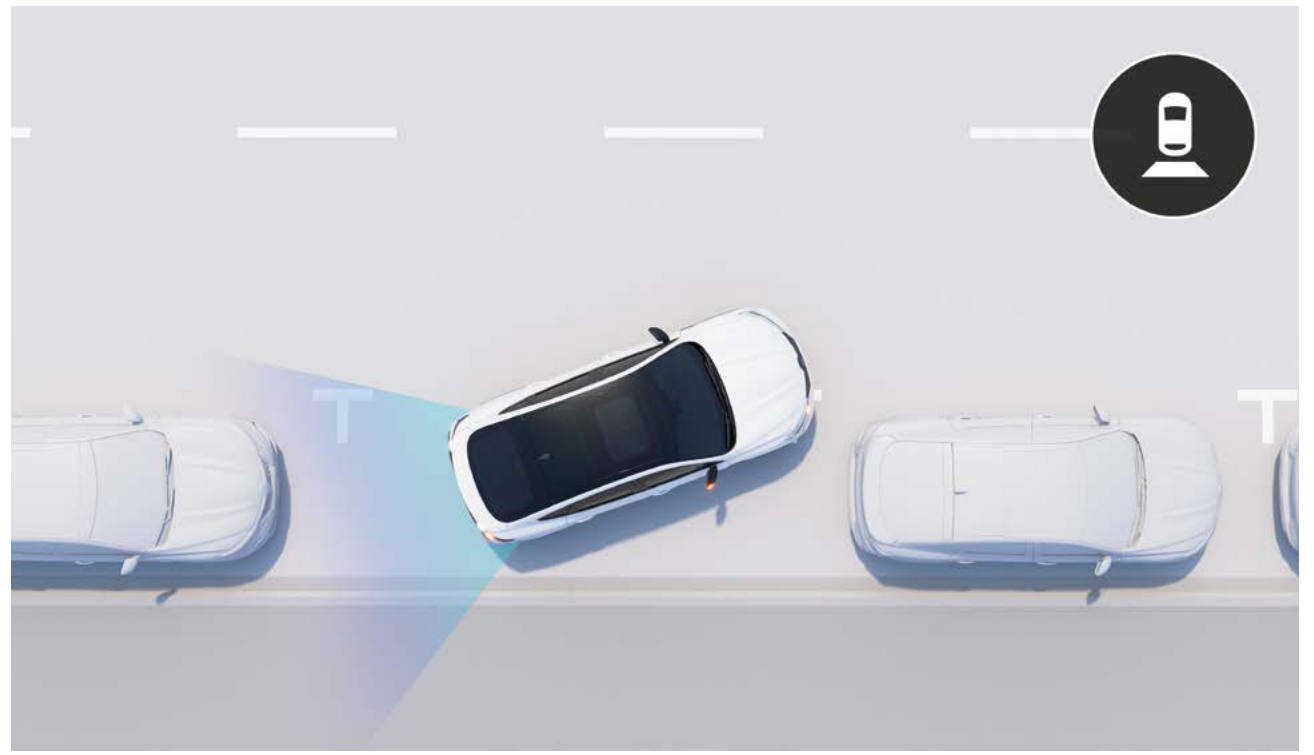

rear view camera
Provides a rear view on the screen when you engage the reverse gear. Superimposed outlines make your manoeuvres easier and safer.

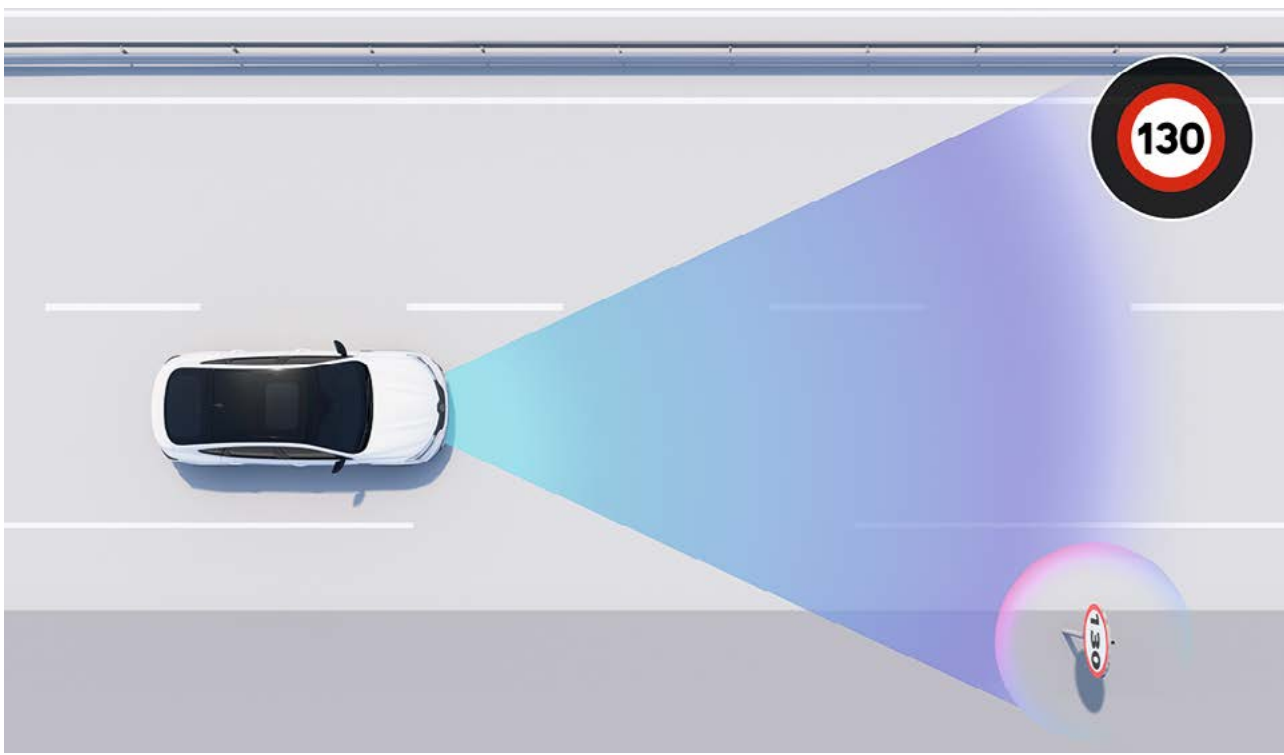

road sign recognition and speeding alert
It keeps you informed via the instrument panel of the speed limits along your route thanks to a camera.

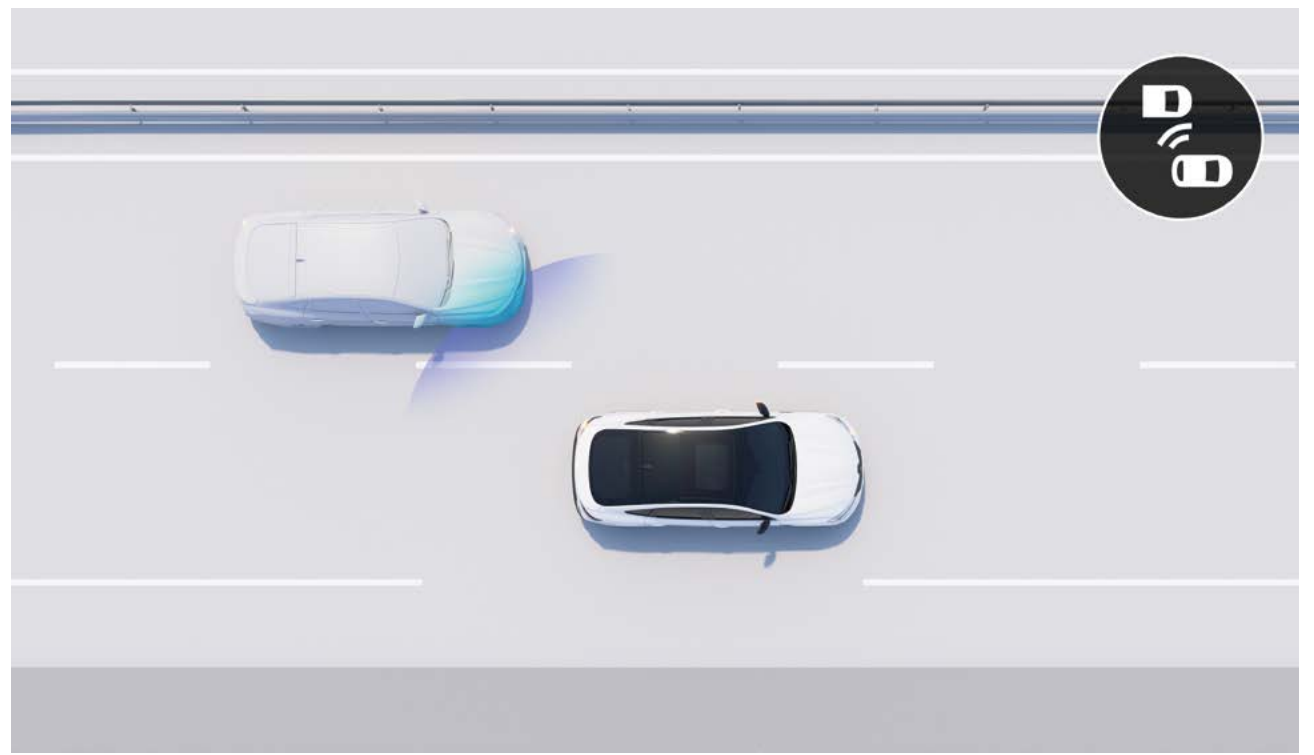

blind spot warning
Active from 10 mph, the system uses the rear side sensors to detect the presence of a vehicle in a non-visible rear side area (blind spot) and warn the driver by switching on a warning light in the door mirror on the side where the vehicle is not visible.



rear cross parking alert when reversing
Exit your parking spot more comfortably. Renault Arkana, equipped with sensors, signals the arrival of a vehicle that you may not have seen.

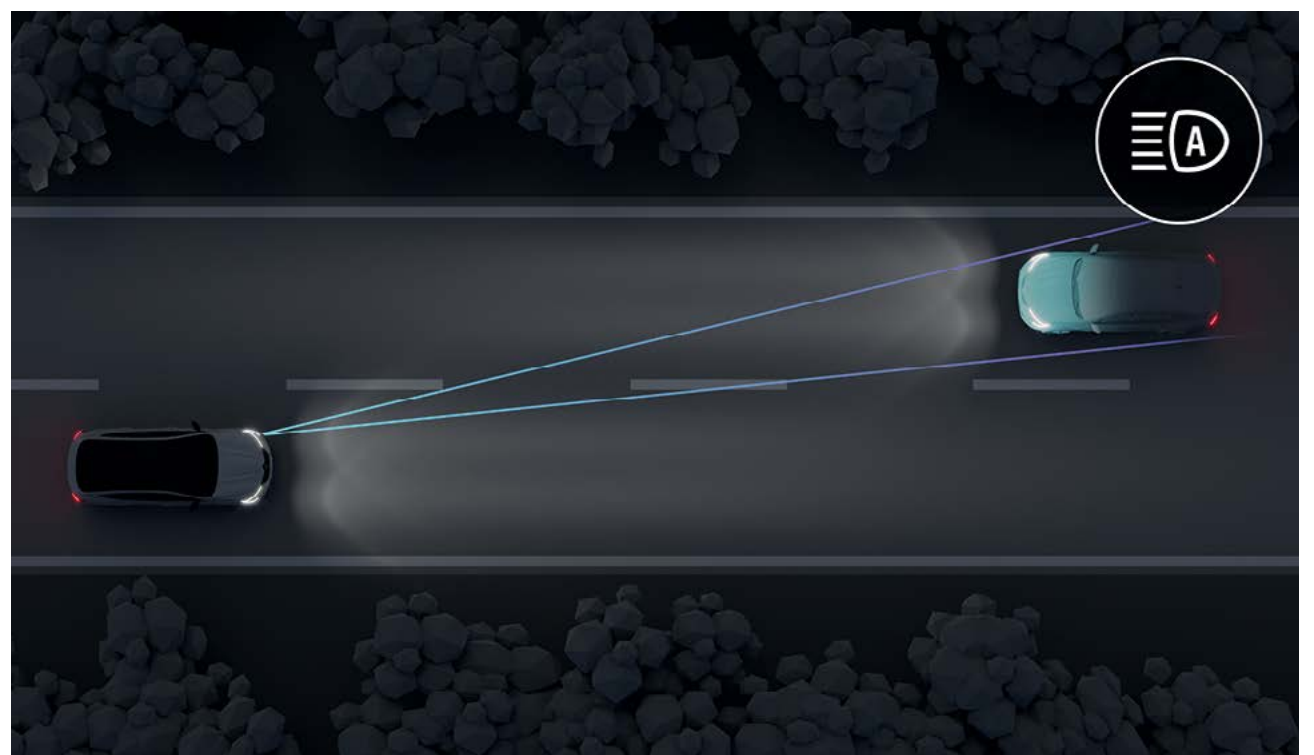

automatic main-beam/dipped headlight activation
Thanks to a camera located on your windscreen that analyses light flows, the system automatically switches between main beam and dipped headlights.

driver-assistance systems

- active driver assist: adaptive cruise control + lane centring
- hill start assist
- speed limiter
- road sign recognition
- road sign recognition and speeding alert
- cruise control

park assist systems

- rear parking sensors
- front parking sensors
- rear cross parking alert when reversing
- rear view camera

safety assistance

- safe following distance warning (information on the driver's screen)
- lane departure warning
- lane keeping assist
- blind spot warning
- automatic main-beam/dipped headlight activation
- automatic emergency braking (pedestrian/cyclist)
- automatic headlights and windscreen wiper with rain sensors across the range

please view individual trims for details of standard ADAS

build yours →

07. customisation

colours



glacier white (non-mp)



pearl white (mp)



metallic black (mp)



metallic grey (mp)



flame red (mp)



zanzibar blue (mp)



midnight blue (mp)

non-mp: non-metallic paint;
mp: metallic paint.
photos not contractually binding.

07. customisation

interior trims



evolution

- easy link 7" with navigation: connected multimedia system with 7" touch screen
- 1/3-2/3 split folding rear bench seat
- 17" bahamas grey alloy wheels



techno

- easy link 9.3" with navigation: connected multimedia system with 9.3" touch screen
- wireless phone charger integrated into the centre console
- 18" silverstone alloy wheels



esprit Alpine (techno +)

- active driver assist
- heated front seats and steering wheel
- 19" esprit Alpine black and grey diamond-cut alloy wheels

download the trims and equipment PDF (6 MB)

07. customisation

upholstery

evolution



black titanium fabric upholstery

techno



black textured coated fabric upholstery

esprit Alpine



special upholstery in biobased textured coated fabric / suedette

wheels

evolution



17" bahamas grey alloy wheels

techno



18" silverstone alloy wheels

esprit Alpine



19" esprit Alpine black and grey diamond-cut alloy wheels

build yours →

07. customisation

accessory packs

storage pack



magnetic smartphone holder



rear tray table & fixing

storage pack + available with 2 rear tray tables & 2 fixings.

protection pack



boot mat



illuminated door sills

side step pack



side steps

style pack (techno)



rear skid plate with double tail pipe



rear spoiler

elegance pack*



underbody lighting



illuminated door sills

cycle pack*



black roof & sunroof not available in UK

quick fix roof bars*



black roof & sunroof not available in UK

roof mounted carriers for 2 bikes

touring pack*



black roof & sunroof not available in UK

quick fix aluminium roof bars



black roof & sunroof not available in UK

roof box 480L

towbar packs



swan neck, removable and electric tow bars available

dash cam pack



KENWOOD front dash cam



KENWOOD rear cam

premium delivery packs



premium mats



safety kit



rubber boot liner

premium delivery pack

premium mats

safety kit

premium delivery pack+

premium mats

safety kit

rubber boot liner

All accessories purchased prior to vehicle registration come with a 3 year manufacturers warranty. Accessories are fitted post production and may have an impact on WLTP fuel (actual) consumption and CO₂ figures

*black roof not available in the UK

 **download the accessories brochure PDF (6 MB)**

build yours →

06. customisation

engines

E-Tech full hybrid 145 hp

fuel

unleaded petrol (E10)
+ full hybrid

maximum power kW (hp) / engine speed (rpm)

69 kW (95) at 5,600 rpm

maximum torque (Nm) / engine speed (rpm)

148 Nm at 3,600 rpm

gearbox

multimode automatic
with dog-clutch and 15 combinations

volumes and weights

kerb weight (kg)

1,435

batteries

type

lithium-ion

voltage (V)

230

capacity (kWh)

1.2

fuel consumption and emissions⁽¹⁾ WLTP⁽²⁾ (Best case / Worst case)

CO₂ (g/km)

105/107

consumption over a combined cycle (l/100 km)

4.7/4.9

(1) fuel consumption and CO₂ emissions are certified using a standard, regulatory method. It is identical for all manufacturers and allows vehicles to be compared.

(2) WLTP (Worldwide Harmonized Light Vehicle Test Procedures): this new protocol provides results much closer to those found in daily use compared with the NEDC protocol.



**download the
engines PDF (6MB)**

dimensions and volumes

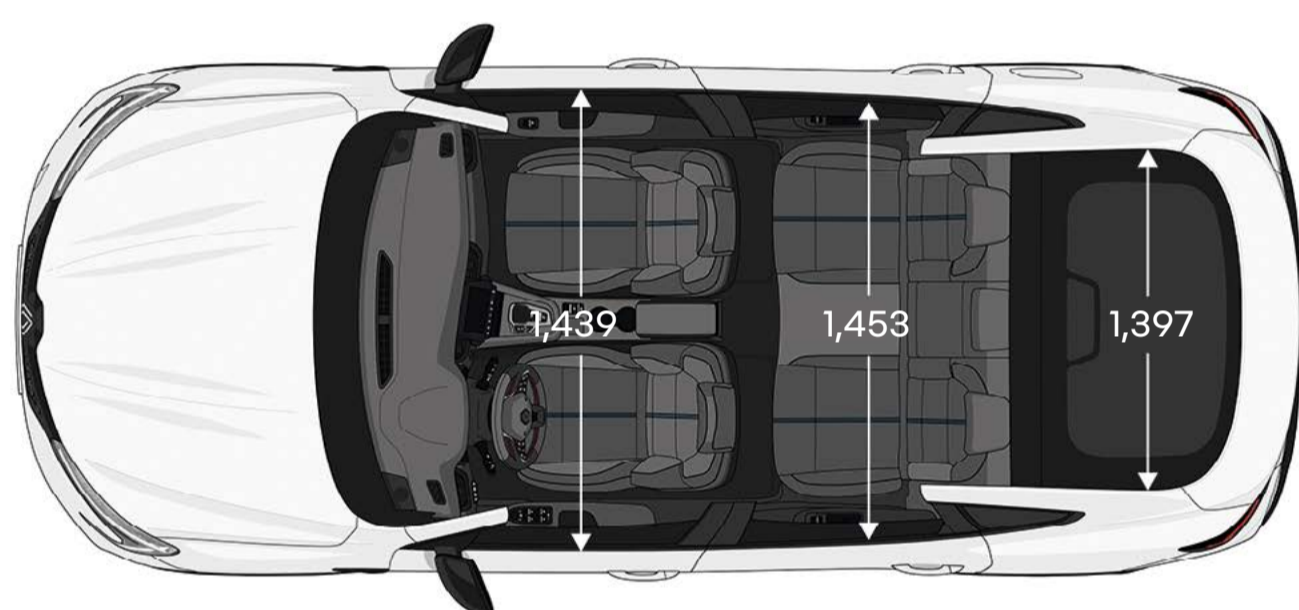
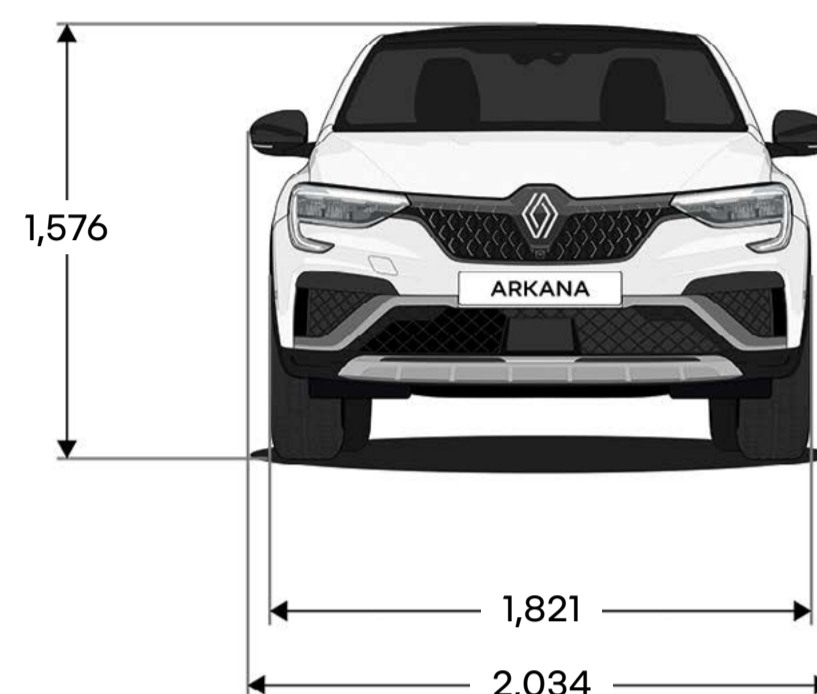
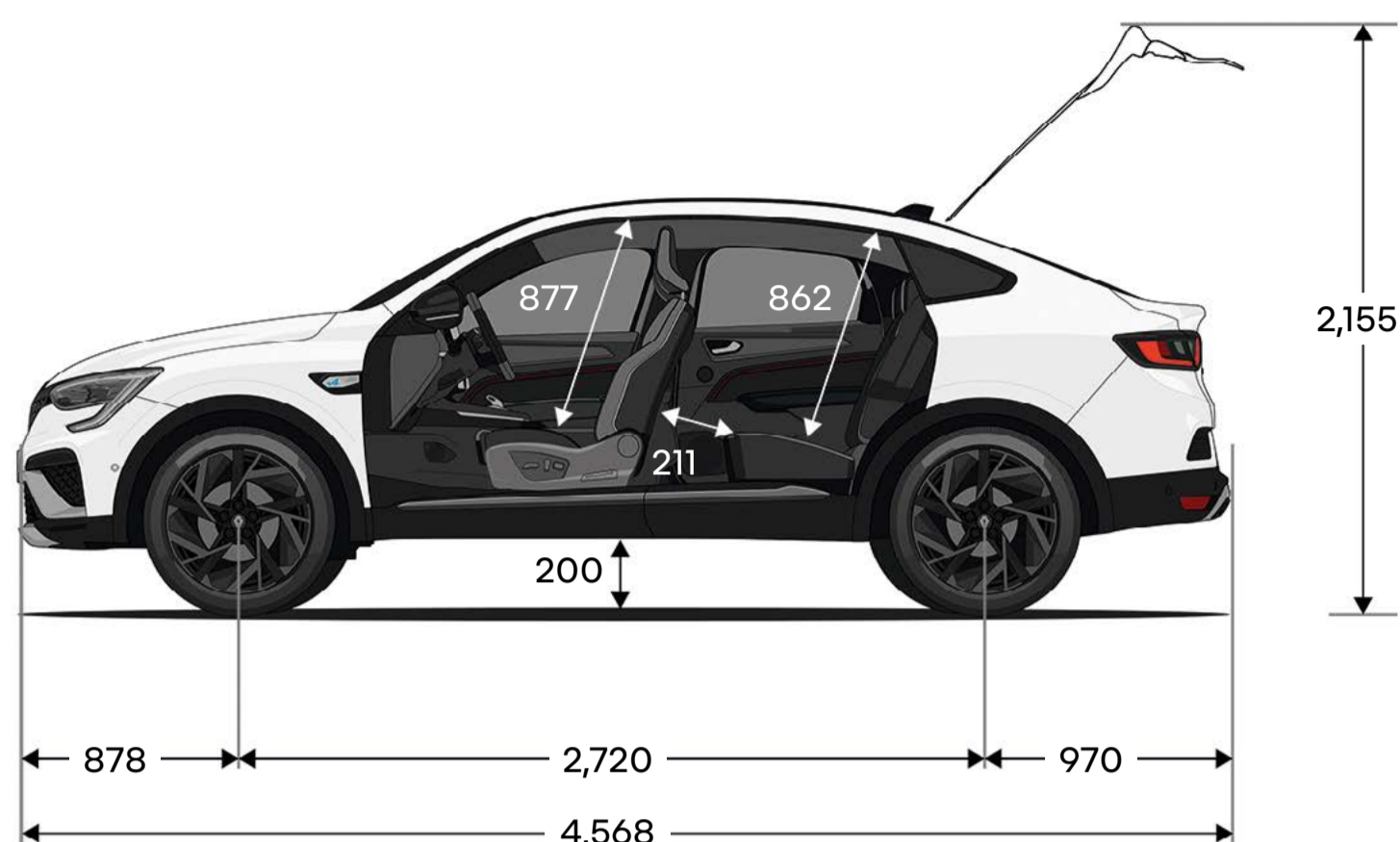

boot volume - VDA standard (litres)

full hybrid

min. boot volume

480

max. boot volume

1,263

dimensions in (mm).

build yours →

Renault services

3 years warranty

Your Renault car is covered by a warranty package for up to 3 years from date of first registration with unlimited mileage during the first 24 months, then limited to a total of 60,000 miles or 3 years, whichever comes first. For further details go to www.renault.co.uk/warranty.html

EasyLife service plan

Renault's EasyLife Service Plan is the ultimate package to provide care-free servicing for your Renault. For more information go to www.renault.co.uk/general-maintenance/service-plans.html

3 years roadside assistance

Should you need it, we'll provide emergency roadside repairs or tow you to the nearest Renault Dealer. For further details visit www.renault.co.uk/assistance.html

Renault car insurance

A car as well designed as your Renault deserves an insurance policy to match. Renault Insurance has been specifically created to provide superb protection for you and your car. Visit www.renault.co.uk/insurance.html

customer relations

Renault knows the value of communicating with its customers and we have established effective ways to keep in touch with you. If after speaking to your local Renault dealership you are not completely satisfied, please contact the Renault UK Customer Service Team on 0344 335 0000[†] (Mon-Fri 8am to 6pm. Closed Saturday, Sunday and on Bank Holidays. Live Chat Mon-Fri 8am to 6pm). You can also visit www.renault.co.uk or write to us at: Renault UK Ltd, The Rivers Office Park, Denham Way, Maple Cross, Rickmansworth, Hertfordshire, WD3 9YS.

[†] Calls to 03 numbers are free if used as part of your inclusive mobile minutes and are charged at local rates from landlines.

Renault care service

We are always by your side to make your driving experience easier and save you time with the maintenance of your Renault: online quotes and appointments, fixed price packages, maintenance contracts, insurance and assistance, personalised My Renault programme, etc. Take advantage of our simple and fast solutions tailored to your needs.

[find out more about Renault care service](#)



Every precaution has been taken to ensure that the contents of this brochure were accurate and up-to-date at the time of its release. This document has been created using pre-production and prototype models. In line with its policy of continuous product improvement, Renault reserves the right to modify the specifications, vehicles and accessories described and featured at any time. Any such modifications are communicated to Renault dealers as quickly as possible. Depending on the country of sale, versions may differ and some equipment may be unavailable (standard, optional or accessory). Please contact your local dealer for the latest information. For reasons to do with the medium, the colours featured in this document may differ slightly from those of the actual paintwork or interior trim. All rights reserved. Reproduction in any format and by any means of all or part of this brochure is prohibited without prior written authorisation from Renault.

Publicis – photo credits: S. Staub, © Renault Marketing 3D-Commerce – April 2024.

Renault recommends 



build yours →