

KWID

vehicle user manual



Welcome aboard your vehicle

This vehicle user manual contains the information necessary :

- for you to familiarise yourself with your vehicle, to use it to its best advantage and to benefit fully from all the functions and the technical developments it incorporates.
- to ensure that it always gives the best performance by following the simple, but comprehensive advice concerning regular maintenance.
- to enable you to deal quickly with minor faults not requiring specialist attention.

It is well worth taking a few minutes to read this manual to familiarise yourself with the information and guidelines it contains about the vehicle and its functions and new features. If certain points are still unclear, our authorised dealers will be pleased to provide you with any additional information.

The following symbol will help you when reading this manual.



These appear in the vehicle and indicate that you should consult the manual for detailed information and/or limits on operations with respect to your vehicle's equipment.

→ anywhere in the manual indicates a transfer to a page.



To indicate a hazard, danger or safety recommendation.

The descriptions of the models given in this manual are based on the technical specifications at the time of writing.

This manual covers all items of equipment (both standard and optional) available for these models, but whether or not these are fitted to the vehicle depends on the version, options selected and the country where the vehicle is sold.

This manual may also contain information about items of equipment to be introduced later in the model year.

The diagrams in the user manual are provided as examples.

Enjoy driving your new vehicle.

Translated from English. Copying or translation, in part or in full, is forbidden unless prior written permission has been obtained from the vehicle manufacturer.

CONTENTS

Welcome aboard your vehicle	4	Driving	57
Exterior	4	Running in, ignition switch	57
Passenger compartment	6	Starting/stopping the engine	58
Driver's position	8	Gear lever, hand brake	60
Driving aids	10	Driving advice, eco-driving	62
Safety on board	12	Maintenance and antipollution advice	65
Identifying a vehicle - labels	14	Driver correction devices, aids	66
The engine compartment (routine maintenance)	16	Tyre pressure monitoring system	69
Breakdown recovery	18	Environment	74
Getting to know your vehicle	20	Automated manual transmission	75
Keys, radio frequency remote control	20	Parking distance control	79
Locking and unlocking the doors	21	Reversing camera	80
Opening and closing the doors	23	Your comfort	82
Engine immobiliser	25	Air vents, air outlets	82
Front seats	26	Heating, ventilation, air conditioning	85
Seat belts	27	Air conditioning	87
Methods of restraint in addition to the front seat belts	30	Windows	88
Child safety	35	Sun visor/grab handle/interior lighting	90
Child Seats	38	Passenger compartment storage	91
Mirrors	41	Accessories socket	92
Driving position, right-hand drive	42	Rear seats	93
Steering wheel	44	Boot	94
Warning lights	45	Longitudinal roof bars	95
TRIP COMPUTER: general information	48	Multimedia equipment	96
TRIP COMPUTER: journey parameters	49	Radio equipment	98
Exterior lighting and signals	50	Maintenance	106
Headlight beam adjustment	51	Bonnet	106
Audible and visual signals	52	Engine oil level	108
Windscreen washing / wiping	53	Levels	111
Fuel tank	55	Battery	114

CONTENTS

Tyre pressure	115	Service and maintenance	176
Bodywork maintenance.....	116	Service and maintenance.....	176
Interior trim maintenance	119	Service checks	178
Practical advice	121		
Puncture, emergency spare wheel.....	121		
Wheel trim, tools.....	123		
Changing a wheel	125		
Tyres.....	127		
Headlights, lights: changing bulbs	130		
Interior lighting: changing bulbs	136		
Radio frequency remote control.....	137		
Fuses	138		
Battery	141		
Windscreen wiper - to lift/replace wiper blades.....	143		
Towing.....	144		
Installation and use of accessories	145		
Operating faults.....	147		
Technical specifications.....	150		
Vehicle identification plates	150		
Engine identification plates	151		
Engine specifications	152		
Technical information for the emergency services .	154		
Dimensions (in metres)	155		
Replacement parts and repairs	157		
Service sheets	158		
Anticorrosion check	163		
Renault new vehicle warranty.....	165		
Renault new vehicle warranty.....	165		
Maintenance Appendix.....	173		
Maintenance Appendix.....	173		

EXTERIOR

1

61811

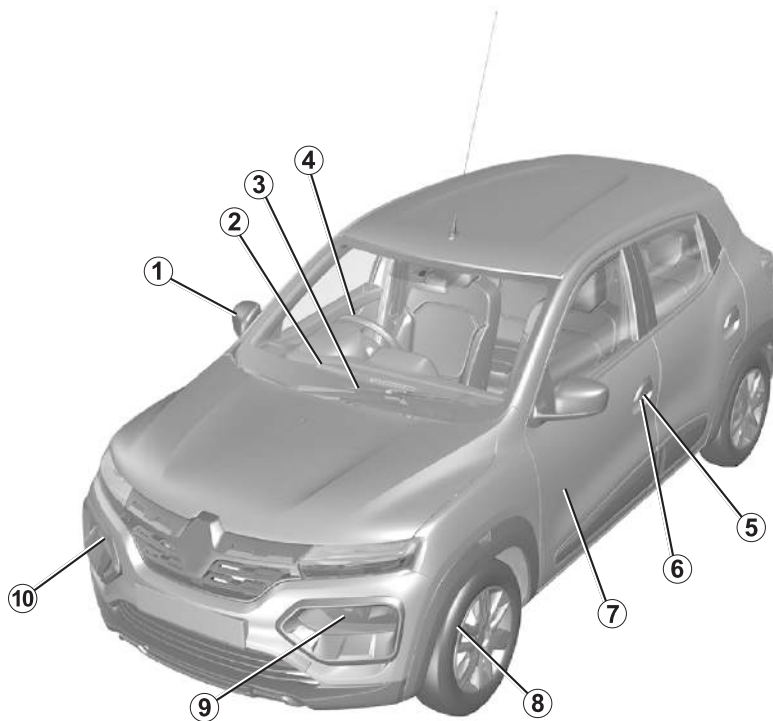

4 - Welcome aboard your vehicle



EXTERIOR

1. Rear view mirrors → 41
2. Demisting → 85
3. Screen wiper, washer → 53
4. Electric windows → 88
5. Key, Remote control → 20
6. Locking, unlocking the doors → 21
7. Bodywork maintenance → 116
8. Tyres → 127
9. Lights: operation → 50
10. Lights: replacement → 130

PASSENGER COMPARTMENT

1

61812

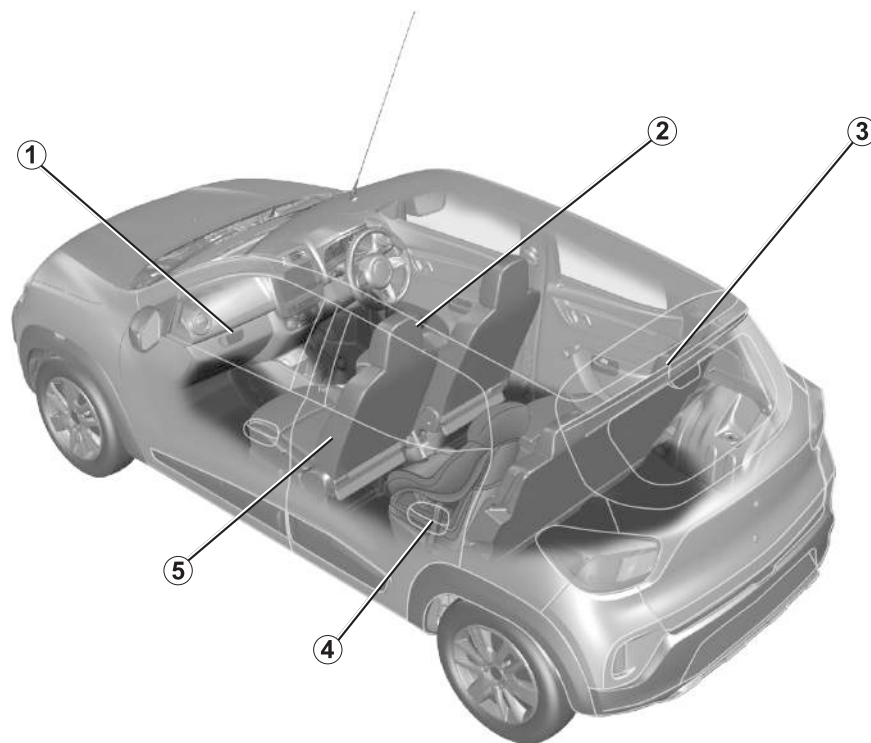

PASSENGER COMPARTMENT

1. Passenger compartment storage/ fittings → 91
2. Adjusting your driving position → 27
3. Rear seat → 93
4. Child safety → 24
5. Front seats → 26

1

DRIVER'S POSITION

1

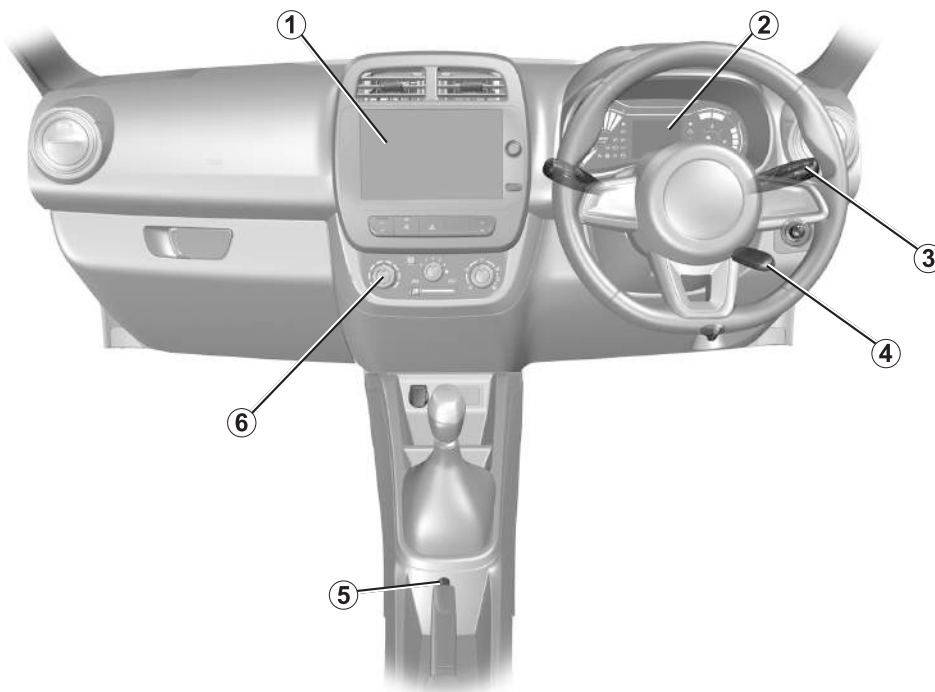

61817

DRIVER'S POSITION

1. Multimedia screen → 96
2. Instrument panel
→ 45
3. Exterior lighting → 50
4. Key ignition switch → 57
5. Hand brake → 60
6. Gear lever → 60
7. Heating/Air conditioning system → 85

1

DRIVING AIDS

1

61835



10 - Welcome aboard your vehicle



DRIVING AIDS

- ABS (anti-lock braking system) → 66
- ESC (electronic stability control) → 67
- Braking assistance → 66
- Hill start assistance → 68
- Tyre pressure loss warning → 69
- Parking distance control → 79
- Reversing camera → 80

SAFETY ON BOARD

1

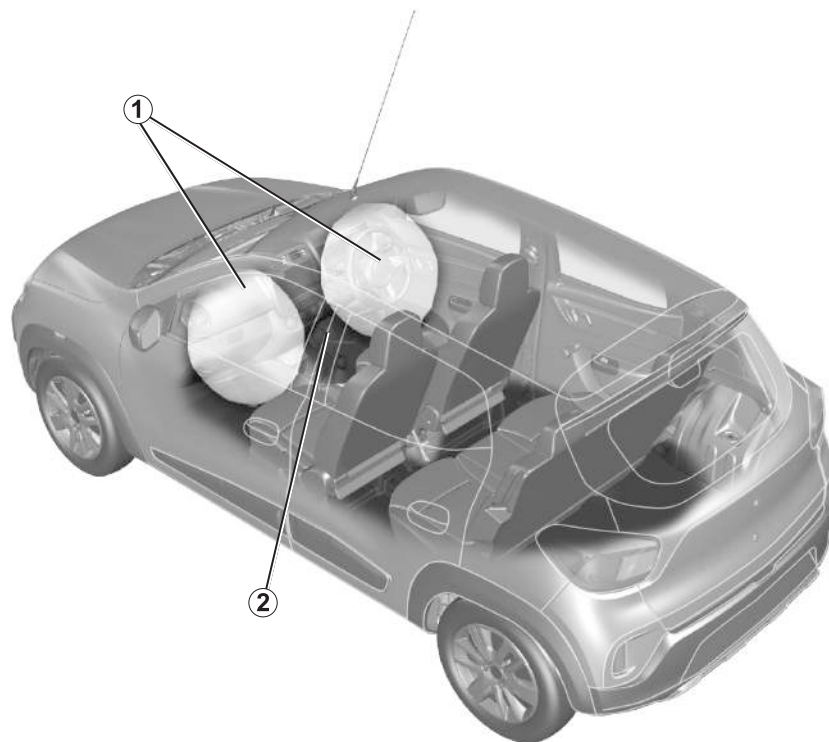

61813

SAFETY ON BOARD

1. Front airbags → 30
2. Seat belts → 27

1

IDENTIFYING A VEHICLE - LABELS

1

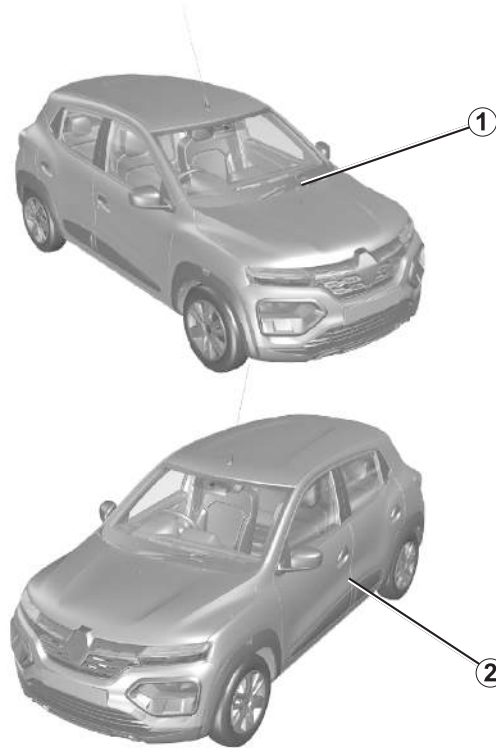

51814

IDENTIFYING A VEHICLE - LABELS

1. Review of a vehicle identification number → 150
2. Tyre pressure labels → 115

THE ENGINE COMPARTMENT (ROUTINE MAINTENANCE)

1

61815

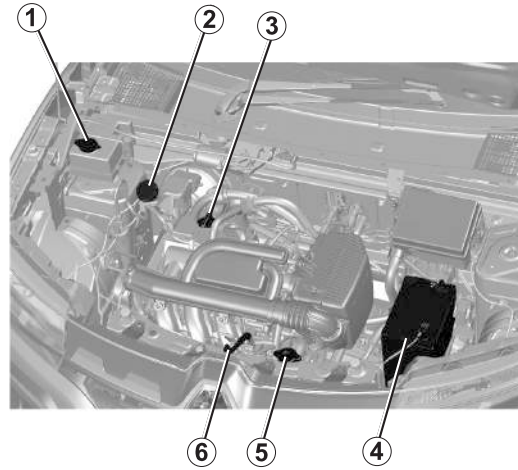

THE ENGINE COMPARTMENT (ROUTINE MAINTENANCE)

1. Windscreen washer fluid → 111
2. Brake fluid → 111
3. Engine oil → 108
4. Battery → 114
5. Coolant level → 112
6. Opening the bonnet → 106

1

BREAKDOWN RECOVERY

1

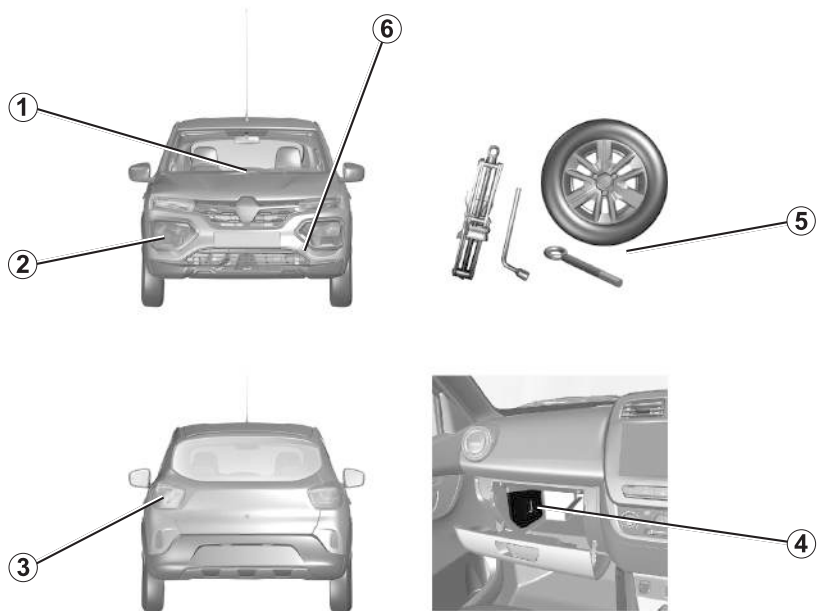

67717

BREAKDOWN RECOVERY

1. Replacing front windscreen wiper blade(s) → 143
 2. Replacing headlight bulbs → 130
 3. Replacement of the rear lights → 131
 4. Fuses → 138
 5. Puncture → 121
- Tools → 123
- Emergency spare wheel → 121
- Changing a wheel → 125
6. Front towing point → 144

KEYS, RADIO FREQUENCY REMOTE CONTROL

2

General information

Key A

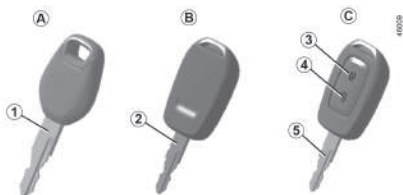

1. Mechanical Key.

Key B

2. Coded key for ignition switch.



Driver's responsibility:
Never leave your vehicle with the keys inside when leaving a child

(or animal) in the car, even for a short period. The reason for this is that the child may endanger himself or others by starting the engine, activating equipment such as the window winders for example, or locking the doors.

The key must not be used for any function other than those described in the handbook (removing the cap from a bottle, etc.).

Advice: Avoid leaving the remote control in hot, cold or humid areas.

Radio frequency remote control C

3. Locks all doors.
4. Unlocks all doors.
5. Coded key for ignition switch.

The remote control unit operating range

This varies according to the environment. It is therefore important when handling the remote control to ensure that you do not lock or unlock the vehicle by inadvertently pressing the buttons.

Interference

The presence of certain objects (metal objects, mobile telephones, or an area with strong electromagnetic radiation, etc.) close to the key may create interference and affect the operation of the system.

Replacement and additional keys or remote controls

If you lose your remote control key or require another, you can obtain one from an approved dealer.

If a remote control or key is replaced, it will be necessary to take the vehicle to an authorised dealer to reset them.

You may use up to four remote control keys per vehicle.

LOCKING AND UNLOCKING THE DOORS

Manual control

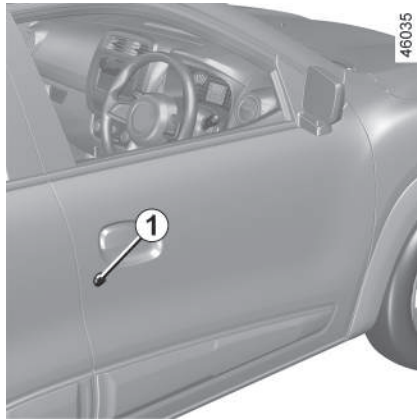

From the outside

Unlock the driver door using the key in door lock **1**.



Driver's responsibility
Never leave an animal, child or adult who is not self-sufficient alone on your vehicle, even for a short time. They may pose a risk to themselves or to others by starting the engine, activating equipment.

RISK OF DEATH OR SERIOUS INJURY.



From the inside

Push in button **2** to lock and lift button **2** to unlock. It is impossible to open the door if **2** is pushed in.

Electric central locking

If equipped, It simultaneously locks or unlocks the doors.

Lock or unlock the doors by pressing switch **3**.

While locking the doors with remote, indicator lights will blink twice to confirm the locking. They will blink only once while unlocking the doors.

Locking the doors without the radio frequency remote control



For example, in the event of a discharged battery or the radio frequency remote control temporarily not working.

2

LOCKING AND UNLOCKING THE DOORS

2

With engine switched off and any door open, press and hold the switch 3 for more than five seconds. When the door is closed, all the doors will be locked.

The vehicle can only be locked from the outside using the radio frequency remote control.

OPENING AND CLOSING THE DOORS

Opening the doors from the outside

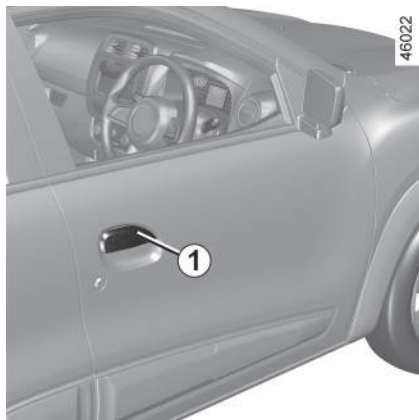

With the doors unlocked → 21, place your hand on the handle **1** and pull towards you.

Special note

Depending on the vehicle, accessories (e.g. radio) stop working either when the engine is switched off or when the doors are locked.



As a safety precaution, the doors should only be opened or closed when the vehicle is stationary.

Opening from the inside



Pull handle **2**.



Driver's responsibility when parking or stopping the vehicle

Never leave an animal, child or adult who is not self-sufficient alone on your vehicle, even for a short time.

They may pose a risk to themselves or to others by starting the engine, activating equipment such as the electric windows or by locking the doors. Also, in hot and/or sunny weather, please remember that the temperature inside the passenger compartment increases very quickly.

RISK OF DEATH OR SERIOUS INJURY.

OPENING AND CLOSING THE DOORS

Child safety

2



If equipped, this feature is to make it impossible for the rear doors to be opened from the inside, move lever **3** on each rear door and check from the inside that the doors are securely locked.

ENGINE IMMOBILISER

(Depends on vehicle)

Engine Immobiliser prevents the vehicle being driven by anyone not in possession of the vehicle's coded ignition key.

Operating principle

The vehicle is automatically protected a few seconds after the ignition is switched off.

If the vehicle does not recognise the coded ignition key or wrong key is used, the engine cannot be started.

System operation

When the ignition is switched on, the vehicle has recognised the code. You can then start the engine.

Vehicle protection

The vehicle will only be protected after the ignition has been switched off.



Operating faults

After the ignition has been switched on, if warning light **1** continues to flash or remains continuously lit, there is a system operating fault.

In all cases, it is essential to contact an approved dealer as only they are qualified to repair the engine immobiliser.

If the coded ignition key is faulty, use the second key (supplied with the vehicle).



Any unauthorised work carried out on the engine immobiliser (computers, wiring, etc.) could be dangerous. Work must be carried out by qualified personnel.



Driver's responsibility when parking or stopping the vehicle

Never leave an animal, child or adult who is not self-sufficient alone on your vehicle, even for a short time. They may pose a risk to themselves or to others by starting the engine, activating equipment such as the electric windows or by locking the doors. Also, in hot and/or sunny weather, please remember that the temperature inside the passenger compartment increases very quickly.

RISK OF DEATH OR SERIOUS INJURY.

FRONT SEATS

Move forward or backward

2



Lift the lever **1** to release and move the seat forward or backward. Release the lever **1** in desired position of seat and ensure that the seat is fully locked into place.

To tilt the seatback

Lift knob **2** upward to unlock recliner mechanism. Tilt the seat back to desired position and release knob. Ensure seat back is locked properly after release.



For safety reasons, carry out any adjustments when the vehicle is not being driven.

We would advise you not to recline the seatbacks too far to ensure that the effectiveness of the seat belts is not reduced. Nothing should be placed on the floor (area in front of driver) as such objects may slide under the pedal during braking manoeuvres, thus obstructing its use.

SEAT BELTS

Always wear your seat belt when travelling in your vehicle. You must also comply with the legislation of the particular country you are in.

Before starting, first adjust your driving position, then ask all occupants to adjust their seat belts to ensure optimum protection.

Adjusting your driving position

(depending on the vehicle)

– **Sit well back in your seat** (having removed your coat or jacket etc.). This is essential to ensure your back is positioned correctly.

– **adjust the distance between the seat and the pedals.** Your seat should be as far back as possible while still allowing you to depress the clutch pedal fully. The seatback should be adjusted so that your arms are slightly bent when you hold the steering wheel.



Make sure that the rear bench seat is locked in correct position so that the rear seat belts will operate efficiently. Refer to the information on the Seats in Section 1.



Incorrectly adjusted or twisted seat belts may cause injuries in the event of an accident.

Use one seat belt per person, whether child or adult. Even pregnant women should wear a seat belt. In this case, ensure that the lap belt is not exerting too much pressure on the abdomen, but do not allow any slack.

Adjusting the seat belts



For correct adjustment and positioning of the seat belts at all seats:

- adjust the seats (seat position and seatback angle, if available);
- sit with your back firmly against the seatback;
- move the chest strap **1** as close as possible to the base of the neck without it actually resting against it (if necessary, adjust the height of the seat belt if available) and make sure that the chest strap **1** is in contact with the shoulder;
- position the lap belt **2** so that it lies flat on the thighs and against the pelvis.

The belt should be worn so that it is as close as possible to your body, i.e.: avoid wearing heavy clothing or keeping bulky objects under the belts, etc.

Locking

Unwind the belt **slowly and smoothly** and ensure that buckle **3** locks into latch **5** (check that it is locked by pulling on buckle **3**).

If the belt jams, allow it to return slightly before attempting to unwind it again.

If your seat belt is completely jammed, pull slowly, but firmly, so that just over 3 cm unwinds. Allow it

SEAT BELTS

to return slightly before attempting to unwind it again.

If there is still a problem, contact an approved dealer.

2

Unlocking

Press the button **4** on latch **5** and the seat belt will be rewound by the inertia reel. Hold by the buckle to make this easier.



- Ensure that no objects are placed in the area around the seat belt latch as they could prevent it from being properly secured.
- Make sure the seat belt latch is properly positioned (it should not be hidden away, crushed or flattened by people or objects).

Seat belt reminder light(Driver/Front Passenger seats)



Depending on the vehicle, It lights up when the ignition is ON and if the driver/front passenger (if seated) seat belt is not fastened, the light flashes and a beep sounds for about

2 minutes when the vehicle reaches a speed of approximately 20 Km/h and above.



an object placed on the passenger seat may activate the warning light in some cases, depending on the vehicle.

Rear seat belt reminder

(Depending on the Vehicle)

The **6** graphic is displayed on the instrument panel in below two states, This informs the driver fastening status of each of the rear seat belts every time:

- the ignition is switched on;
- Status of fastening or unfastening of a rear seat belt.

Understanding the graphic 6 :

- indicator filled: seatbelt fastened;
- indicator unfilled: seatbelt unfastened;

Depending on the vehicle, the **6** symbol appears when the ignition is switched ON, if a rear seat belt is buckled state to unbuckled state or any state change. When the vehicle speed is less than approximately 12

mph (20 km/h), the **6** symbol appears for at least 65 seconds.



When the vehicle speed reaches or exceeds 12 mph (20 km/h), if one of the rear seat belts is or becomes unfastened during the journey:

- a beep is emitted for 35 seconds; and
- the **6** symbol is displayed for at least 65 seconds and the symbol for the seat concerned changes to unfilled.

Always make sure that the rear passengers are properly fastened in and that the number of seat belts indicated corresponds to the number of rear seats occupied.

SEAT BELTS



- No modification may be made to the component parts of the originally fitted restraint system: seat belts, seats and their mountings. For special operations (e.g. fitting child seats), contact an authorised dealer.
- Do not use devices which allow any slack in the belts (e.g. clothes pegs, clips, etc.): a seat belt which is worn too loosely may cause injury in the event of an accident.
- Never wear the shoulder strap under your arm or behind your back.
- Never use the same belt for more than one person and never hold a baby or child on your lap with your seat belt around them.

Adjusting the rear seat belts



Adjusting the rear seat belts

Follow the same instructions of front seat belts to adjust/fasten/unlocking the rear seat belts.

Adjust the seat belt strap as indicated in the image for height adjustment.



The belt should never be twisted. Following an accident, have the seat belts checked and replaced. If necessary, always replace your seat belts as soon as they show any signs of wear. Make sure that the buckle is inserted into the appropriate latch.

METHODS OF RESTRAINT IN ADDITION TO THE FRONT SEAT BELTS

Depending on the vehicle, they will consist of:

- **seat belt inertia reel pretensioners;**
- **chest-level load limiters;**
- **air bags for driver and front passenger.**

These systems are designed to act independently or together when the vehicle is subjected to a frontal impact.

Depending on the severity of the impact, the system can trigger:

- seat belt locking;
- the seat belt inertia reel pretensioner (which engages to correct seat belt slack);
- airbags.

Pretensioners



The pretensioners (in driver side) hold the seat belt against the body, holding the occupant more securely against the seat, thus increasing the seat belt's efficiency.

With the ignition on, following a significant frontal impact and depending on the severity of the impact, the system may trigger the seat belt inertia reel pretensioner **1**, which instantly retracts the seat belt.



- Have the entire restraint system checked following an accident.
- No operation whatsoever is permitted on any part of the system (pretensioners, air bags, computers, wiring) and the system components must not be reused on any other vehicle, even if identical.
- To avoid incorrect triggering of the system which may cause injury, only qualified personnel from an approved Dealer may work on the pretensioner and air bag system.
- The electric trigger system may only be tested by a specially trained technician using special equipment.
- When the vehicle is scrapped, contact an approved Dealer for disposal of the pretensioner and air bag gas generators.

Load limiter (in driver side)

Above a certain severity of impact, this mechanism is used to limit the

METHODS OF RESTRAINT IN ADDITION TO THE FRONT SEAT BELTS

force of the belt against the body so that it is at an acceptable level.

Airbags for driver and front passenger

Fitted to the driver and passenger side.

The presence of this equipment is indicated by the word "Air bag" on the steering wheel and dashboard (air bag zone **A**) and, depending on the vehicle, a symbol on the lower section of the windscreen.

Each air bag system consists of :

- an air bag and gas generator fitted on the steering wheel for the driver and in the dashboard for the front passenger ;
- an electronic unit for system monitoring which controls the gas generator electrical trigger system ;
- a single  warning light on the instrument panel.



The air bag system uses pyrotechnic principles. This explains why, when the air bag inflates, it will generate heat, produce smoke (this does not mean that a fire is about to start) and make a noise upon detonation. In a situation where an air bag is required, it will inflate immediately and this may cause some minor, superficial grazing to the skin or other problems.



Operation

This system is only operational when the ignition is switched on.

In a severe **frontal** impact, the air bags inflate rapidly, cushioning the impact of the driver's head and chest against the steering wheel and of the front passenger against the dashboard. The air bags then deflate immediately so that the passengers are not in any way hindered from leaving the vehicle.

METHODS OF RESTRAINT IN ADDITION TO THE FRONT SEAT BELTS

Operating faults

2

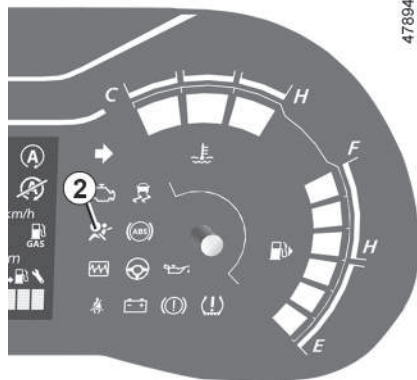

47894

This warning light **2**  will light up on the instrument panel when the ignition is switched on and then go out after a few seconds.

If it does not light up when the ignition is switched on, or comes on when the engine is running, there is a fault in the system.

Contact your approved Dealer as soon as possible. Your protection will be reduced until this fault is rectified.

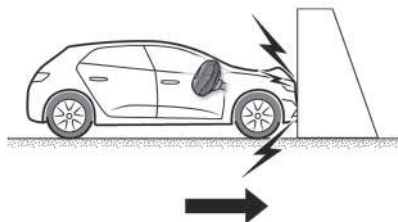

44446

The following cases cause the pretensioners or airbags to operate.
In a frontal impact against a rigid (non-deformable) surface at an impact speed equal or greater than 25 km/h (16 mph)

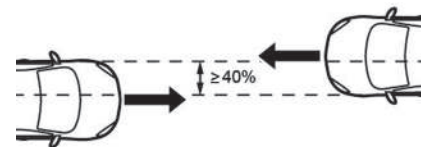

44448

In a frontal impact with another vehicle of an equivalent or higher category, with an impact area equal to or greater than 40 %, where the speed of both vehicles is equal or greater than 40 km/h (25 mph).

METHODS OF RESTRAINT IN ADDITION TO THE FRONT SEAT BELTS

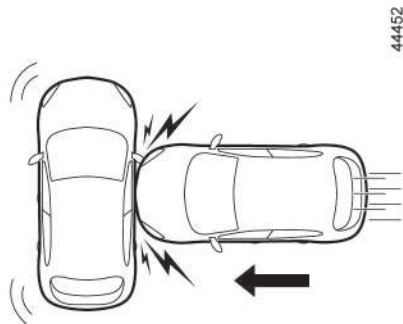

In a side impact with another vehicle of an equivalent or higher category, at an impact speed equal to or greater than 50 km/h (31 mph).



In the following examples, the pretensioners and airbags could operate :

- impacts to the underside of the vehicle from kerbs, for example ;
- potholes ;
- a fall or a hard landing ;
- stones ;

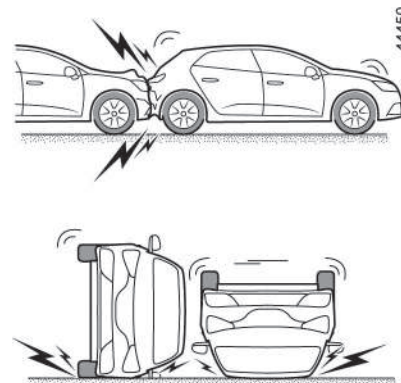

In the following examples, the pretensioners and airbags might not operate :

- in the event of a rear impact, however severe ;
- if the vehicle overturns ;

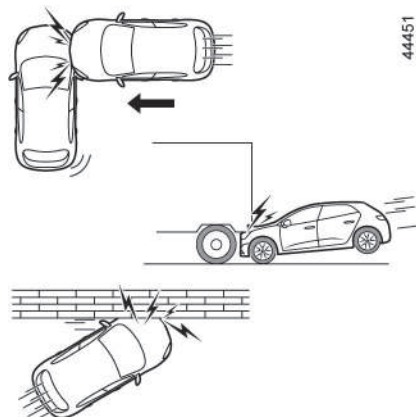

- in the event of a side impact, affecting the front of the vehicle;
- in the event of a frontal impact, under the tail of a lorry;
- in the event of a frontal impact against an obstacle with a sharp angle;

All of the warnings below are given so that the air bag is not obstructed in any way when it is inflated and also to prevent the risk of serious injuries caused by items which may be dislodged when the air bag inflates.



Warnings concerning the driver's air bag

- Do not modify the steering wheel or the steering wheel boss.
- Do not cover the steering wheel boss under any circumstances.
- Do not attach any objects (badge, logo, clock, telephone holder, etc.) to the steering wheel boss.
- The steering wheel must not be removed (except by qualified personnel from our Network).
- When driving, do not sit too close to the steering wheel. Sit with your arms slightly bent (see the information on "Adjusting your driving position" in Section 1). This will allow sufficient space for the air bag to deploy correctly and be fully effective.

Warnings concerning the passenger air bag

- Do not attach or glue any objects (badge, logo, clock, telephone holder, etc.) to the dashboard on or near the air bag.
- Do not place anything between the dashboard and the passenger (pet, umbrella, walking stick, parcels, etc.).
- The passenger must not put his or her feet on the dashboard or seat as there is a risk that serious injuries may occur. In general, parts of the body should be kept away from the dashboard (knees, hands, head, etc.).
- The devices in addition to the front passenger seat belt should be reactivated as soon as a child seat is removed, to ensure the protection of the passenger in the event of an impact.

A REAR-FACING CHILD SEAT MUST NOT BE FITTED TO THE FRONT PASSENGER SEAT

CHILD SAFETY

General information

Carrying children

Children, and adults, must be correctly seated and strapped in for all journeys. The children being carried in your vehicle are your responsibility.

A child is not a miniature adult. Children are at risk of specific injuries as their muscles and bones have not yet finished growing. The seat belt alone would not provide suitable protection. Use an approved child seat and ensure you use it correctly.

CHILD RESTRAINT SEAT provision is given in Rear Left seat belt.



To prevent the doors being opened, use the childproof locks (refer to the information on "Locking/unlocking the doors" in → 21).



A collision at 30 mph (50 km/h) is the same as falling a distance of

10 metres. Transporting

a child without a restraint is the equivalent of allowing him or her to play on a fourth floor balcony without railings.

Never travel with a child held in your arms. In the event of an accident, you will not be able to keep hold of the child, even if you yourself are wearing a seat belt.

If your vehicle has been involved in a road accident, replace the child seat and have the seat belts and fittings checked.



It is recommended that children and infants are seated in child restraint.

You choose a child restraint that fits your vehicle. Always follow the manufacturer's instruction for installation and use. In addition there are many types of child restraint available for larger children that should be used for maximum protection.

Using a child seat

The level of protection offered by the child seat depends on ability to restrain child and on its installation. Incorrect installation risks the protection of the child in the event of harsh braking or an impact.

Before purchasing a child seat, check that it complies with the regulations and that it can be fitted in your vehicle. Consult an approved dealer to find out which seats are recommended for your vehicle.

Before fitting a child seat, read the manual and respect its instructions. If you experience any difficulties during installation, contact the man-

CHILD SAFETY

manufacturer of the equipment. Keep the instructions with the seat.



Set a good example by always fastening your seat belt and teaching your child:

- to strap themselves in correctly.
- to always get in and out of the car at the kerb, away from busy traffic.

Do not use a second-hand child seat or one without an instruction manual.

Check that there are no objects in the vicinity of the child seat which could impede its operation.



Never leave a child unattended in the vehicle. Check that your child is always strapped in and

that the belt or safety harness used is correctly set and adjusted. Avoid wearing bulky clothing which could cause the belts to slacken → 27.

Never let your child put their head or arms out of the window. Check that the child is in the correct position for the entire journey, especially if asleep.

Choosing a child seat mounting

Attachment via the seat belt

The seat belt must be adjusted in order to ensure it works in the event of sudden braking or impact.

Ensure that the strap paths indicated by the child seat manufacturer are respected.

Always check that the seat belt is correctly fastened by pulling it up, then pulling it out fully whilst pressing on the child seat.

Check that the seat is correctly held by moving it from side to side and

back to front: the seat should remain firmly fixed.

Check that the child seat has not been installed at an angle and that it is not resting against a window.



Do not use the child seat if it may unfasten the seat belt restraining it: the base of the seat must not rest on the buckle and/or catch of the seat belt.



The seat belt must never be twisted or the tension relieved. Never pass the shoulder strap under the arm or behind the back. Check that the seat belt has not been damaged by sharp edges. If the seat belt does not operate normally, it will not protect the child. Consult an approved dealer. Do not use this seat until the seat belt has been repaired.

CHILD SAFETY

Fitting a child seat: General information

Some seats are not suitable for fitting child seats. The following diagrams show you how to attach a child seat.

The types of child seats indicated may not be available. Before using a different child seat, check with the manufacturer that it can be fitted.



Fit the child seat in rear seat Left Side. Check that when installing the child seat in

the vehicle it is not at risk of coming loose from its base. If you have to remove the headrest, check that it is correctly stored so that it does not come loose under harsh braking or impact.

Always attach the child seat to the vehicle even if it is not in use so that it does not come loose under harsh braking or impact.

In the rear side seat

A carrycot can be installed across the vehicle and will take up at least

two seats. Position the child with his or her feet nearest the door. Move the front seat as far forward as possible to install a rear-facing child seat, then move back the seat in front as far as it will go, although without allowing it to come into contact with the child seat.

For the safety of the child in the forward-facing seat,

- move the seat in front of the child forwards, and set the position of the seatback to avoid contact between the seat and the child's legs.

Check that the child seat is resting against the back of the rear seat.



Ensure that the child seat or the child's feet do not prevent the front seat from locking correctly → 26.

58035



2



IMPORTANT

Since front passenger airbag triggering and the position of a rear-facing child seat are incompatible, **NEVER** use a rear-facing child restraint on a seat with an airbag.

The airbag could cause SERIOUS OR FATAL INJURY if inflated.

CHILD SEATS

Attachment by seat belt

2

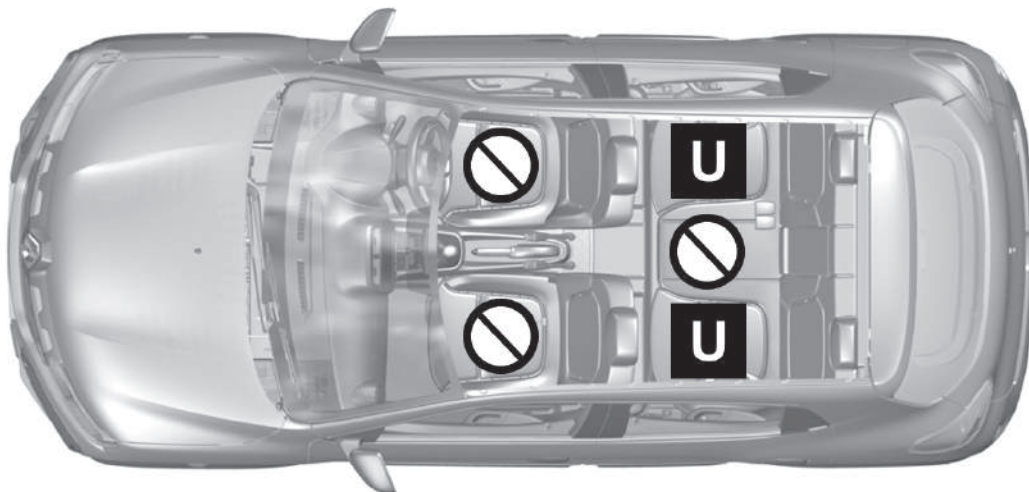

71435

CHILD SEATS

U Seat which allows a child seat with "Universal" approval to be attached by a seat belt.

⊘ Seat not suitable for fitting child seats.

2



Using a child safety system which is not approved for this vehicle will not correctly protect the baby or child. They risk serious or even fatal injury.



Check that your child is always strapped in and that the belt or safety harness used is correctly set and adjusted → 27. If necessary, adjust the seat position accordingly.

CHILD SEATS

2

Installation table

The table below summarises the information already shown on the previous diagram in order to ensure the regulations in force are respected.

Seating Position					
Mass Group	Weight of the child	Front passenger seat	Rear Outboard		Rear Centre
			LEFT	RIGHT	
Group 0	Upto 10 kg	X	U	U	X
Group 0+	Upto 13 kg	X	U	U	X
Group I	9 to 18 kg	X	U	U	X
Group II	15 kg to 25 kg	X	U	U	X
Group III	22 kg to 36 kg	X	U	U	X



RISK OF DEATH OR SERIOUS INJURY: never fit a child seat on the front seat if the vehicle has a passenger airbag which cannot be deactivated.

Refer to the "Child safety equipment" booklet available from the network to choose the seat suited to your child and recommended for your vehicle.

X= Seat not suitable for fitting child seats.

U= Seat which allows a child seat with "Universal" approval to be installed using a seat belt; check that it can be fitted.

MIRRORS

Door mirrors without manual adjustment lever

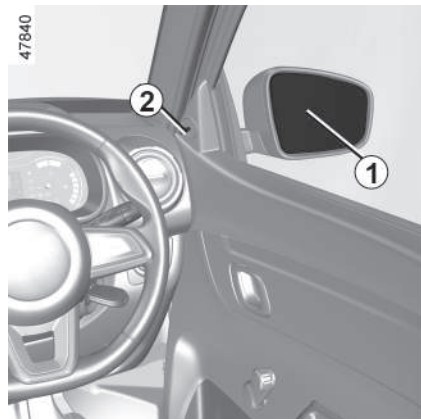

Adjust the door mirrors **1** according to rear vision by touching the periphery of the glass plate.

Door mirrors with manual adjustment lever

To adjust the door mirror, move lever **2**.

Foldable door mirrors

The door mirrors can be folded in manually against the door window.

Door mirror with electrical adjustment **3**

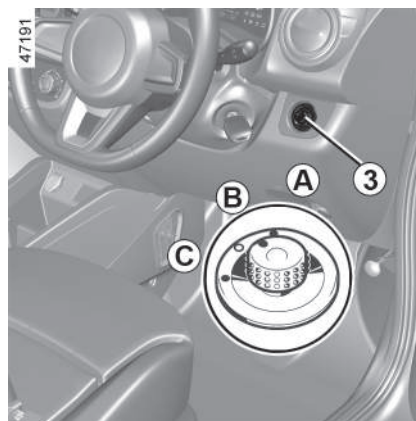

- position **A** to adjust the right-hand door mirror;
- position **C** to adjust the left-hand door mirror;
- position **B** is inactive position.



For safety reasons, carry out any adjustments when the vehicle is not being driven.



Objects observed in the door mirror glass are actually closer than they appear. For your safety, take this into account in order to correctly assess the distance before any manoeuvre.

2

Interior rear view mirror **4**

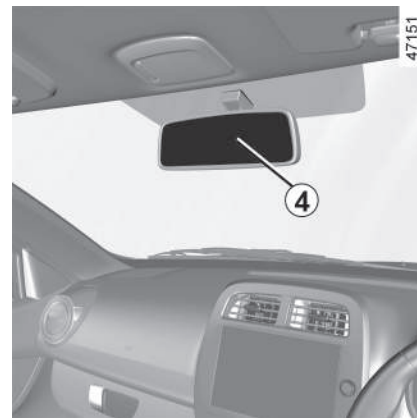

The interior rear-view mirror **4** is manually adjustable. When driving at night, tilt the mirror to avoid being dazzled by the headlights of the vehicle behind.

DRIVING POSITION, RIGHT-HAND DRIVE

2

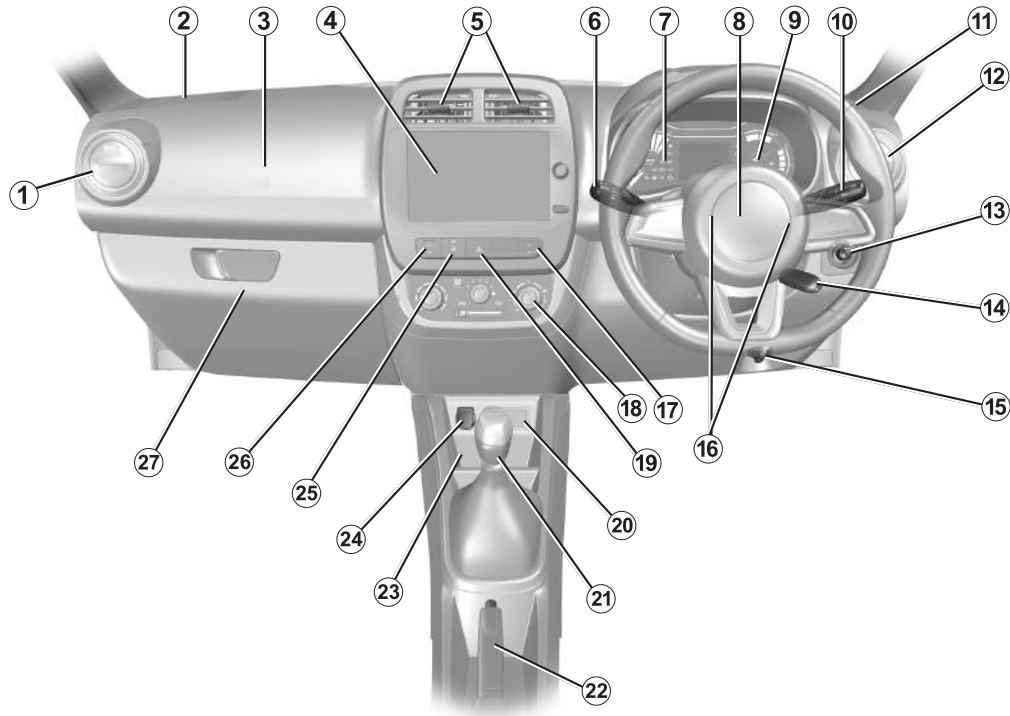

61817



DRIVING POSITION, RIGHT-HAND DRIVE

The presence of the equipment DEPENDS ON THE VEHICLE VERSION AND COUNTRY.

- 1.** Left side air vent
- 2.** Left side speaker
- 3.** Location for passenger airbag
- 4.** Location for radio/ Navigation System
- 5.** Centre air vents
- 6.** Steering column stalk for wind-screen wash/wiper
- 7.** Instrument panel
- 8.** Location for driver's airbag
- 9.** Trip switch
- 10.** Stalk
 - direction indicator lights,
 - exterior lights,
- 11.** Right side speaker
- 12.** Right side air vent
- 13.** Electrical ORVM adjustment switch
- 14.** Key slot for ignition/start
- 15.** Beam height adjustment control
- 16.** Horn
- 17.** Electric power window control(driver side)
- 18.** Heating and ventilation controls
- 19.** Hazardous switch
- 20.** USB/AUX port(for changing + media connect)
- 21.** Gear lever
- 22.** Handbrake
- 23.** Centre console storage
- 24.** 12V Accessories socket
- 25.** Electric central locking switch
- 26.** Electric power window control (passenger side)
- 27.** Glove Box

STEERING WHEEL

Power-assisted steering

Never drive with an inadequately charged 12V battery.

Variable power assisted steering

The variable power-assisted steering system is equipped with an electronic control system which alters the level of assistance to suit the vehicle speed.

Steering is made easier during parking manoeuvres (for added comfort) while the force needed to steer increases progressively as the speed rises (for enhanced safety at high speeds).



Never leave the steering wheel on full lock when the vehicle is stationary.



With the engine switched off, or if there is a system fault, it is still possible to turn the steering wheel. The force required will be greater.



Never switch off the ignition when travelling downhill, and avoid doing so in normal driving (power steering and brake servo will not function).

WARNING LIGHTS

The presence and operation of the warning lights **DEPEND ON THE EQUIPMENT AND COUNTRY.**

Instrument panel A



If no lights or sounds are apparent, this indicates a fault in the instrument panel. This indicates that it is essential to stop immediately (as soon as traffic conditions allow). Ensure that the vehicle is correctly immobilised and contact an approved Dealer.



Main beam headlight tell-tale light.



Dipped beam headlight tell-tale.



Left-hand direction indicator tell-tale.



Right-hand direction indicator tell-tale.



Gear shift indicator - Higher gear



Gear shift indicator - Lower gear



Orange warning light



comes on while you are driving, **drive carefully** to an authorised dealer as soon as possible. Failure to follow this recommendation risks damaging your vehicle.

Over Speed Warning beep

Primary Warning

When vehicle speed exceeds around 80 km/h (50 MPH), a beep sounds intermittently until the driver reduces the speed to less than around 80 km/h (50 MPH)

Secondary Warning

When vehicle speed exceeds around 120 km/h (75 MPH), a beep sounds continuously until the driver reduces the speed to less than around 120 km/h (75 MPH), after which it will switch to the primary warning.

WARNING LIGHTS



The red warning light  requires you to stop immediately, for your own safety, as soon as traffic conditions allow. Switch off the engine and do not restart it. Contact an Authorised Dealer.



Handbrake "on" warning light and brake circuit incident warning light

This comes on when the ignition is switched on and goes out when parking brake is dis-engaged. If it comes on during braking and is accompanied by a beep, it indicates that fluid level in circuit is low. It may be dangerous to continue driving. Contact approved dealer.



Air bag warning light

This comes on when the ignition is switched on and goes out after a few seconds.

If it does not go out when the ignition is switched on, or comes on when the engine is running, there is a fault in the system.

Contact your approved Dealer as soon as possible.



Warning light malfunction (red or orange)

Warning light (orange)

This lights up when the ignition is switched on and goes out as soon as the engine is started. It may come on in conjunction with other warning lights on the instrument panel. It means you should **drive very carefully** to an authorised dealer as soon as possible. If you fail to follow this recommendation, you risk damaging your vehicle.

Urgent stop warning light (red)

This lights up when the ignition is switched on and goes out as soon as the engine is started. It lights up at the same time as other warning lights, and is accompanied by a beep. It requires you to stop immediately, for your own safety, as soon as traffic conditions allow. Switch off the engine and do not restart it. Contact an approved Dealer.



Variable power assisted steering warning light

Warning light (orange)

When engine gets off suddenly (e.g., in traffic conditions), it lights up

till the engine gets started. There is no functional effect and is the normal functioning of the car.

Warning light (red)

It lights up when the ignition is switched on and goes off after a few seconds. If it lights while driving, it indicates that there is a fault in the system.

At this time, greater efforts are required to operate the steering wheel.

Contact your approved Dealer as soon as possible.



Coolant temperature warning display

This bar display comes ON when ignition is ON and remains lit permanently. If the display blinks while driving, this means the engine is overheating. Stop and allow the engine to run at idle speed for a minute or two. The temperature should drop. If not, stop the engine. Let it cool down. Contact an authorised dealer if necessary.



Low fuel level warning light

The warning light get ON when the ignition is ON and remains lit permanently. If it blinks when driving, fill up with fuel as soon as possible

WARNING LIGHTS



Warning light for monitoring exhaust gas

It comes on when the ignition is switched on and then goes out.

- If it lights up continuously, consult an approved dealer as soon as possible.
- If it flashes, reduce the engine speed until the light stops flashing. Contact your approved Dealer as soon as possible.

Refer to the information on “Advice: antipollution, fuel economy, driving” in Section 2.



Anti-lock braking warning light

This lights up when the ignition is switched on and goes out after a few seconds.

If it does not go out after the ignition is switched on, or lights up when driving, there is a fault with the ABS. Braking will then be as normal, without the ABS system.

Contact an approved Dealer as soon as possible.



Oil pressure warning light

This comes when ignition is ON and goes out after few seconds. If it comes on when you are driving ac-

companied and a beep, it is essential to stop and switch off the ignition. Consult an approved Dealer as soon as possible.



Battery charge warning light

If it comes on when you are driving, it indicates that the circuit has discharged. Consult an approved Dealer as soon as possible.



Tyre under-inflation warning light

It lights up when the ignition or the engine is switched on and goes off after a few seconds → 69.



Warning light for the electronic stability program (ESP)

There are several reasons for the warning light to come on : see “Electronic Stability Program ESC with understeer control and traction control” in → 66



ESP OFF WARNING LIGHT

This lights up when the ignition is switched on and goes out after a second.

This will come in display when driving if the ESP OFF switch pressed manually (Applicable only if the ESP OFF switch equipped)

TRIP COMPUTER: GENERAL INFORMATION

2

Trip computer 1



The display depends on the vehicle and the country.

Scroll through the following information by pressing the button **2**.

- a) Total distance recorder.
- b) Trip distance recorder.
- c) Fuel Used in Litre (from last reset).
- d) Average Fuel Consumption (from last reset).
- e) Current Fuel Consumption.
- f) Estimated Fuel range (DTE - distance to empty).
- g) Distance travelled from Last reset.

h) Average speed from the Last Reset.

Resetting the trip mileage

To reset the trip mileage recorder, the display must show the Trip meter function.

Press and hold button **2**.

Interpreting some of the values displayed after resetting

The values showing average fuel consumption, range and average speed will become more stable and reliable the further you travel after pressing the reset button.

For the first few kilometres after pressing the reset key you will notice that the range increases as you travel. This range takes into account the average fuel consumption since the last time the reset button was pressed.

Refer to the table on the following pages showing display examples.

The current fuel consumption may decrease when,





- the vehicle stops accelerating.
- the engine reaches its operating temperature (if the engine was cold when the reset key was pressed).

- when driving from an urban area onto the open road.





Resetting is automatic when the maximum capacity of any of the memories is exceeded.

TRIP COMPUTER: JOURNEY PARAMETERS

The display of information shown below **DEPENDS ON THE VEHICLE EQUIPMENT AND COUNTRY.**

DISPLAY	Interpreting the display selected
	Total distance recorder
	Trip distance recorder
	Fuel used (since the last time the reset button was pressed)
	Average fuel consumption (since the last time the reset button was pressed) This value is displayed after driving 400 metres. This takes into account the distance travelled and the fuel used since the last time the reset button was pressed.

The display of information shown below **DEPENDS ON THE VEHICLE EQUIPMENT AND COUNTRY.**

DISPLAY	Interpreting the display selected
	Current fuel consumption
	Estimated range with remaining fuel
	Distance travelled (since the last time the reset button was pressed)
	Average speed (since the last time the reset button was pressed)

EXTERIOR LIGHTING AND SIGNALS

2

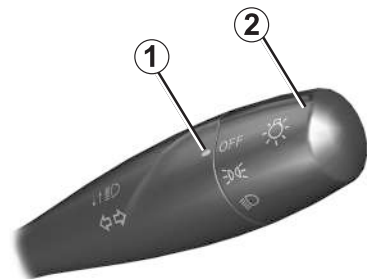

64908

turn to dipped headlight, pull the stalk **2** upward.

Switching off the lights

 Turn the end of stalk **2** until the symbol is opposite mark **1**.

Daytime running lights function (front lights only)

If fitted on the vehicle, the daytime running lights come on automatically with no action on stalk, when the engine is started and they go off once the engine is switched off. When the position function is ON, the daytime running lights are switched off.

Headlight flasher : Pull stalk **2** towards you to flash the headlights.

Side lights

 Turn the end of stalk **2** until the symbol is opposite mark **1**.

Dipped beam headlight

 Depending on the vehicle, turn the end of stalk **2** down until the symbol is opposite mark **1**.

Main beam headlights

 With the dipped beam headlights lit, push stalk **2**. The indicator on instrument panel comes on. To re-

HEADLIGHT BEAM ADJUSTMENT

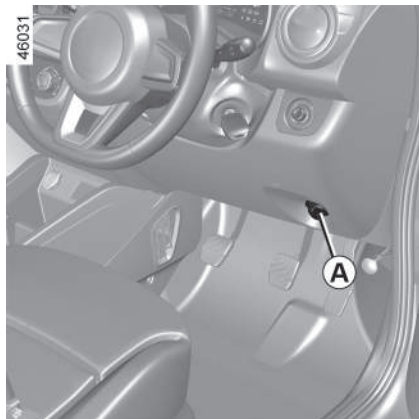

Knob **A** is used to adjust height of the headlight beam according to load. Turn knob **A** anticlockwise to lower the beams and clockwise to raise them.

	Examples of positions for adjusting the knob A according to the load
Only Driver	Zero
Driver + front passenger	Zero
Driver + Trunk	o

Driver + All passengers	oo
Driver + All passengers+Trunk	ooo

Temporary adjustment

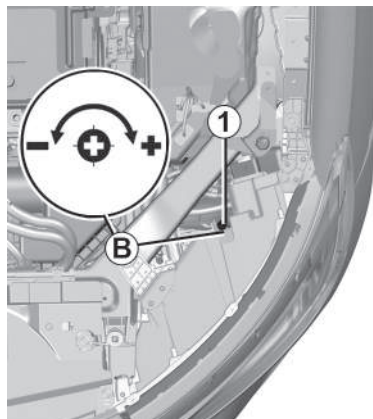

Open the bonnet and identify the marking **B** next to one of the front headlight projectors.

For each headlight, use a screwdriver to turn the screw **1** a quarter of a turn towards the "-" symbol to lower the beams.

Return to the original position once your trip is over: turn the screw **1** a

quarter of a turn towards the "+" symbol to raise the beams.

AUDIBLE AND VISUAL SIGNALS

Horn 1

2



Press on the centre or sides of the highlighted (horn pad) to use the horn.

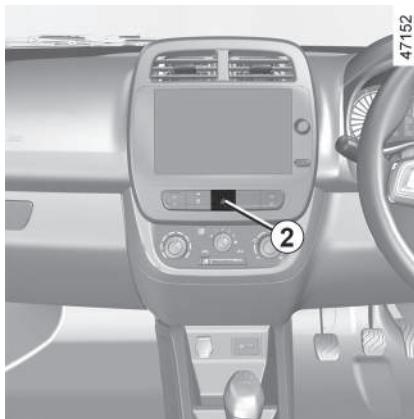

Hazard warning lights



Press switch **2**.

This switch activates all four direction indicators and the side indicator lights simultaneously.

It must only be used in an emergency to warn drivers of other vehicles that you have had to stop in an area where stopping is prohibited or unexpected, or that you are obliged to drive under special conditions.

Direction indicators



Move stalk **3** parallel to the steering wheel and in the direction you are going to turn it.

When driving on motorway, the steering is not usually turned sufficiently to enable the stalk to return automatically to home position. There is intermediate position where the stalk will not be held for lane change indication and there will be 3 blinks of indicator lights in dedicated direction.

If it does not return back automatically, release the stalk manually and it will return to its home position.

WINDSCREEN WASHING / WIPING



Windscreen Wiper

 With the ignition on, move the stalk **1** around the steering wheel (depending on the version):

- A** One time Mist Removal Function.
- B** Park.
- C** Intermittent wiping (depends on vehicle version) - The wiper will pause for several seconds between sweeps.
- D** Normal wiping speed.
- E** Fast wiping speed.

Windscreen Washing

 With the ignition on, pull stalk **1** towards you (depending on the version).

A brief pull will trigger a single sweep of the wiper, in addition to the windscreen washer.

A longer pull will trigger multiple sweeps until the release of stalk **1** in addition to the windscreen washer. Once the stalk is released, there will be three sweeps of the wiping and one additional sweep after a few seconds.



Before any action on the windscreen (washing the vehicle, de-icing, cleaning the windscreen, etc.), return stalk **1** to position **B** (park). Risk of injury and/or damage.



When working in the engine compartment, ensure that the windscreen wiper stalk **1** is in the **B** position (park). Risk of injury.

If you switch off the ignition before switching off the windscreen wiper the blade will stop at random on the windscreen. After switching the ignition back on, simply move stalk **1** to position **B** to place them in the park position.

WINDSCREEN WASHING / WIPING

2



Efficiency of a wiper blade

Check the condition of the wiper blades. How long they last depends on you :

- it must remain clean : clean the blade and the screen regularly with soapy water ;
- do not use it when the screen is dry ;
- free it from the screen when it has not been used for a long time.

In all cases, replace it as soon as it begins to lose efficiency : approximately once a year.

Precaution for using the wipers

- In freezing or snowy weather conditions, clear the screen before starting the wipers (risk of wiper motor overheating) ;
- ensure that no objects are obstructing the travel of the blade.

FUEL TANK



Opening the Fuel Flap

- Stop the Engine.
- Pull up the fuel filler flap release lever **1** located on the floor, right front side of driver's seat which unlocks the fuel filler flap **A**.
- Turn the fuel filler cap **B** counter-clockwise slowly and completely unscrew the cap.
- Remove the cap.

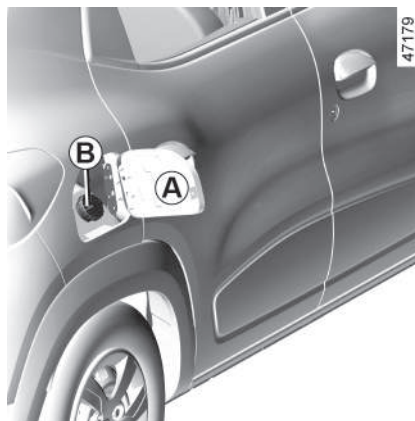

- After refuelling, replace cap. Turn it clockwise and screw completely.
- Push the fuel filler flap **A** closed until it latches.

For details on filling the tank, refer to the information on "Filling with fuel".

NOTE: In cold weather, if the fuel flap does not open, tap the door lightly. Then try to open it again.



Fuel filler cap: this is a specific type. If you have to replace it, make sure the new cap

is of the same type as the original. Contact an approved Dealer. Never place the cap near a source of heat or flame.

Do not add any additives to the fuel, you risk damaging the engine.

Do not wash the filler area with a high-pressure washer.

Fuel grade

Use a high-grade fuel that complies with the legislation in force in each country and which must comply with the specifications given on the label on fuel flap **A** → 152.

Petrol version

It is essential to use unleaded petrol. The octane rating (RON) must comply with the information provided under → 152.

FUEL TANK



Fuels that comply with the Indian standards with which vehicle engines marketed in India are compatible → 152.



To fill up with fuel, the engine must be stopped (and not only in standby for the vehicle fitted with the Stop and Start function): you must switch off the ignition → 57.
Fire hazard.



Do not use ethanol-based fuel if your vehicle is not compatible with this fuel.
Do **not** add reagent to the fuel otherwise you risk damaging the engine. If you wish to add an additive to the fuel, use a product approved by our Technical Department.
Consult an approved Dealer.



No modifications whatsoever are permitted on any part of the fuel supply system (electronic unit, wiring, fuel circuit, injector, protective covers, etc.) as this may be dangerous (unless undertaken by qualified Network personnel).

Filling up with fuel

With the ignition off, insert the nozzle **fully** before turning it on to fill the fuel tank (risk of splashing).

Keep the nozzle in this position throughout the entire filling operation. When the pump cuts out automatically at the end of the filling procedure, a maximum of two further filling attempts may be made, as there must be sufficient space in the fuel tank to allow for expansion.

Make sure that no water enters the fuel tank during filling.

After filling, refit the cap **B** and close the fuel flap **A** to avoid any water or foreign bodies from entering the system.

Always make sure that the cap **B**, the flap **A** and its perimeter remain clean and free of dust, mud, dirt, etc.

Petrol version

It is **essential** to use unleaded petrol. Using leaded petrol will damage the antipollution system and may lead to a loss of warranty.

Capacity of the fuel tank: 28 litres approximately.



Persistent smell of fuel

If you notice a persistent fuel odour you should:

- stop the vehicle as soon as traffic conditions allow it and switch off the ignition;
- switch on the hazard warning lights and ask your passengers to leave the vehicle and stay clear of the traffic.
- contact an authorised dealer.

RUNNING IN, IGNITION SWITCH

Running in

For the first **1,000 km**, do not exceed 80 km/h in the highest gear.

You may only expect top performance from your vehicle after approximately **3,000 kms**.

Oil change frequency : Please refer to your vehicle's maintenance schedule.

NOTE : During the running in period, do not accelerate hard while the engine is still cold and do not let the engine to run in higher rpm.

Service intervals : refer to the Maintenance Schedule for your vehicle.

Stop and steering lock position St



To lock : remove the key and turn the steering wheel until the steering column locks.

To unlock : turn the key and the steering wheel slightly.

Accessories position A

When the ignition is switched off, any accessories (radio, etc.) will continue to function.

Ignition on position M

The ignition is switched on :
- the engine may be started.

Start position D

If the engine fails to start at the first attempt, turn the key back to home position before activating the starter again.

Release the key as soon as the engine starts.

3

STARTING/STOPPING THE ENGINE

Starting the engine

In cold condition : switch on the ignition for several seconds **before** starting the engine, so that it is easier to start the engine.

Petrol injection

- Activate the starter **without depressing the accelerator**.
- Release the key as soon as the engine starts.



Once switching on the ignition, wait for three seconds then crank the engine.



Never leave your vehicle with the key or remote control inside and never leave a child

(or a pet) unsupervised, even for a short while.

The reason for this is that the child may endanger himself or others by starting the engine, activating equipment such as the window winders for example, or locking the doors.

Risk of serious injury.

Never switch off the ignition before the vehicle has stopped completely. Once the engine has stopped, the brake servo, power assisted steering and passive safety equipment such as air bags will no longer operate.

The steering is locked when the key is removed.

Special note

Depending on the vehicle, accessories (e.g. radio) stop working either when the engine is switched off or when the doors are locked.

Starting problems

To avoid damage, **do not keep trying to start the engine (by pushing or towing the vehicle) without having identified and corrected the cause of the fault.**

If the fault cannot be identified, do not continue to try and start the engine, but contact an approved dealer.

The following operating conditions should be avoided :

- driving for long periods when the low fuel level warning light is lit.
- using leaded petrol.
- using fuel or lubrication additives which are not approved.

Operating faults such as :

- faulty ignition, running out of fuel or disconnected spark plugs resulting in the engine misfiring or cutting out when driving.
- loss of power.

may cause overheating, reducing efficiency **which may irreparably damage vehicle components and also the vehicle.**

If you notice any of the above operating faults, have the necessary repairs carried out as soon as possible by an approved dealer.

STARTING/STOPPING THE ENGINE

These faults may be avoided by regularly taking your vehicle to an approved Dealer at the intervals specified in the Maintenance Schedule.



Do not park the vehicle or run the engine in locations where combustible substances or materials such as grass or leaves can come into contact with the hot exhaust system.

GEAR LEVER, HAND BRAKE

Selecting reverse gear



(vehicle in stationary condition)

Vehicles with manual gearbox: refer to the grid on the gear lever knob **1**.

Pull the release knob **A** in upward direction and then engage the reverse gear. Shifting the reverse gear should not be done quickly. Wait for three seconds approximately and shift the reverse gear.

Vehicles with an automated manual transmission → 75.

The reversing lights will come on as soon as reverse gear is selected with the ignition on.

Handbrake

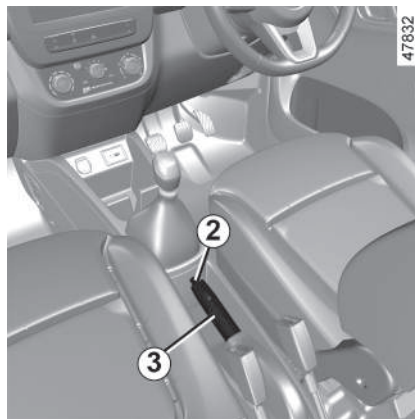

To release

Firmly press and hold the brake pedal. Pull lever **3** up slightly up, press button **2** and then lower the lever to the floor completely.

The red warning light on the instrument panel will come on and a sound if you are driving with an incorrectly released handbrake at speeds over 8 km/h (5 mph).

To apply

Pull lever **3** fully upwards and make sure the vehicle is immobilised.



Depending on the gradient and/or vehicle load, it may be necessary when stationary to apply the handbrake by at least a further two notches and engage a gear (1st gear or reverse gear).



An impact to the underside of the vehicle while manoeuvring (e.g. : striking a post, raised kerb or other street furniture) may result in damage to the vehicle (e.g. : deformation of an axle). To avoid any risk of accident, have your vehicle checked by an approved dealer.



Make sure that the handbrake is properly released when driving (red indicator light off), otherwise overheating, or even damage, may occur.

GEAR LEVER, HAND BRAKE



Note :

- Apply hand brake fully when parking on a slope ;
- When parking on an downhill condition, move the rotary knob to position **"R" (in case of Automated manual transmission) or move the gear shift lever to "R"** (in case of manual transmission).
- When parking on an uphill grade, move the rotary knob to position **"D" (in case of Automated manual transmission) or move the gear shift lever to « 1st gear position »** (in case of manual transmission).

DRIVING ADVICE, ECO-DRIVING

Fuel consumption is accredited in accordance with a standard regulatory method. Identical for all manufacturers, this enables vehicles to be compared with one another.

3

Consumption in real time depends on vehicle usage conditions, the equipment fitted and the user's driving style. To optimise fuel consumption, please refer to the following advice.

Depending on the vehicle, you have different functions to help you reduce your fuel consumption:

- the rev counter;
- the gear change indicator.

Gear change indicator 1

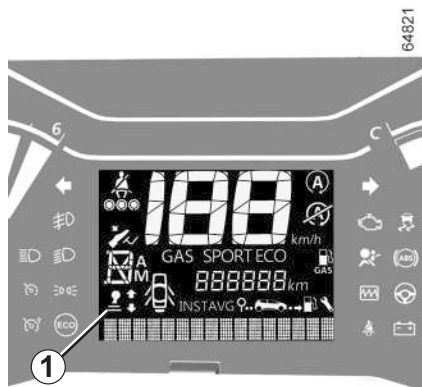

Depending on the vehicle, to obtain optimum consumption levels, a warning light on the instrument panel lets you know the best time to move up or down a gear:



shift up a gear;



downshift a gear.

If you regularly follow this indicator, you will reduce your vehicle's fuel consumption.

Driving advice and ECO driving

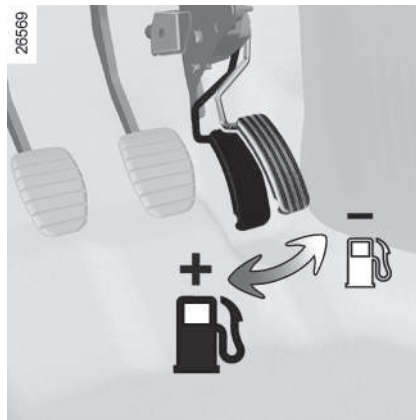

Behaviour

- Drive carefully for the first few kilometres until the engine reaches its normal operating temperature, rather than let it warm up while the vehicle is stationary;
- High speeds significantly affect the vehicle's fuel consumption;

Examples (at a steady speed):

- reducing the speed from 130 km/h (80 mph) to 110 km/h (68 mph) approximately saves up to 20% of fuel approximately;
 - reducing the speed from 90 km/h (56 mph) to 80 km/h (50 mph) approximately saves up to 10% of fuel approximately.
- Dynamic driving involving heavy and frequent acceleration and braking is expensive on fuel in comparison to the time saved;
 - Do not overrev the engine in the intermediate gears. You should always use the highest gear possible;
 - Avoid sudden acceleration;
 - Brake as little as possible. If you anticipate an obstacle or bend in advance, you may then simply release the accelerator pedal;
 - Do not try to maintain the same speed up a hill, accelerate no more than you would on the level.

DRIVING ADVICE, ECO-DRIVING

- Keep your foot in the same position on the accelerator pedal;
- Double declutching and accelerating before switching off are unnecessary in modern vehicles;
- On versions with an sequential/automatic gearbox, it is preferable to keep the gear lever in position **D**;
- Bad weather, flooded roads:



Do not drive through water if it is higher than the lower edge of the wheel rim.



Obstructions to the driver

On the driver's side, only use mats suitable for the vehicle, attached with the pre-fitted components, and check the fitting regularly. Do not lay one mat on top of another.

There is a risk of wedging the pedals

Heating level

It is normal to notice an increase in the vehicle's fuel consumption when

using the heating (particularly when the outside temperature drops below zero) or air conditioning.

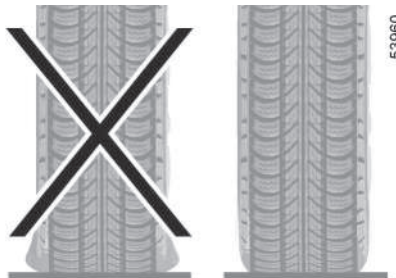

Tyres

- An underinflated tyre increases fuel consumption;
- To optimise fuel consumption, set the highest speed tyre pressure or the recommended pressure indicated on the edge of the driver's door → 115;
- The use of non-recommended tyres can increase fuel consumption.



Advice on use

- Electricity is fuel – switch off all the electrical components which are not really needed. **However** (safety first), keep your lights on when the visibility is bad ("see and be seen");
- Use the air vents. Driving with the windows open at 100 km/h (62 mph) will increase fuel consumption by 4% approximately;
- Never fill the fuel tank right to the brim to avoid overflow;
- **On vehicles equipped with non-automatic air conditioning**, switch off the air conditioning when it is not required.

DRIVING ADVICE, ECO-DRIVING

Advice for reducing consumption and helping to preserve the environment:

3

If the vehicle has been parked in the sun, open the doors for a few moments to let the hot air escape before starting the engine.

- Do not leave an empty roof rack fitted to the vehicle;
- Avoid using the vehicle for "door-to-door" calls (short journeys with long waits in between) because in such conditions the engine never reaches its optimal operating temperature.

MAINTENANCE AND ANTIPOLLUTION ADVICE

Your vehicle complies with criteria for recycling and recovering vehicles at the end of their service life, which entered into force in 2015.

Some of the parts on your vehicle have been designed to be recycled later. These parts are easily removable in order to be collected and reprocessed in recycling networks.

Furthermore, by virtue of its design, moderate fuel consumption and initial settings, your vehicle also conforms to current anti-pollution regulations. The manufacturer is actively striving to reduce pollutant exhaust gas emissions and to save energy. However, the fuel consumption of your vehicle and the level of pollutant exhaust gas emissions are also your responsibility. Ensure that it is maintained and used correctly.

Maintenance

It is important to remember that failure to respect anti-pollution regulations could lead to legal action being taken against the vehicle owner.

In addition, replacing engine, fuel supply system and exhaust components with parts other than those originally recommended by the manufacturer may alter your vehicle

so that it no longer complies with anti-pollution regulations.

Have your vehicle adjusted and checked by an authorised dealer, in accordance with the instructions given in your maintenance schedule : they will have all the equipment necessary for ensuring that your vehicle is maintained to its original standard.

Engine adjustments

- **Spark plugs** : for optimum conditions of use, output and performance the specifications laid down by our design department must be strictly applied. If the spark plugs have to be changed, use the make, type and gap specified for your vehicle's engine. Contact an authorised dealer for this.
- **Air filter, fuel filter** : a choked element will reduce efficiency. It must be replaced.
- **Ignition and idle speed** : no adjustment is needed.

Exhaust gas monitoring system

The exhaust gas monitoring system will detect any operating faults in the vehicle's antipollution system.

If this system malfunctions, toxic substances may be released into the atmosphere or damage may occur.



This warning light on the instrument panel will indicate if there are any faults in the system :

This lights up when the ignition is switched on and goes out when the engine is started.

- If it lights up continuously, consult an approved dealer as soon as possible ;
- if it flashes, reduce the engine speed until the light stops flashing. Contact an authorised dealer as soon as possible.

DRIVER CORRECTION DEVICES, AIDS

Depending on the vehicle, this is composed of:

- **the ABS (anti-lock braking system) ;**
- **the emergency brake assist ;**
- **electronic stability program ESC with understeer control and traction control.**

3



These functions are an additional aid in the event of critical driving conditions, enabling the vehicle behaviour to be adapted to suit the driving conditions. However, the functions do not take the place of the driver. They do not increase the vehicle's limits and should not encourage you to drive more quickly. Therefore, they can under no circumstances replace the vigilance or responsibility of the driver when manoeuvring the vehicle (the driver must always be ready for sudden incidents which may occur when driving).

ABS (anti-lock braking system)

Under heavy braking, the ABS prevents the wheels from locking, allowing the stopping distance to be managed and keeping control of the vehicle. Under these circumstances, the vehicle can be steered to avoid an obstacle whilst braking. In addition, this system can increase stopping distances, particularly on roads with low surface grip (wet ground etc.).

You will feel a pulsation through the brake pedal each time the system is activated. The ABS does not in any way improve the vehicle's physical performance relating to the road surface and roadholding. It is still essential to follow the rules of good driving practice (such as driving at a safe





In an emergency, apply firm and continuous pressure to the brake pedal. There is no need to pump it repeatedly. The ABS will modulate the force applied in the braking system.



Under some driving or climatic conditions, occasional brake squeaks, squeals or other noises may be heard. Occasional brake noise during light to moderate stops is normal and does not affect the function or performance of the brake system.

Operating faults

- If the  warning light on the instrument panel comes on while you are driving, **the brakes will still work normally without ABS ;**
- If the  and  warning lights on the instrument panel come on while you are driving, **there is a fault in the braking system.**

In both cases, consult an approved Dealer.

Emergency brake assist with electronic brake distribution

(depending on the vehicle)

This system supplements the ABS and helps reduce vehicle stopping distances.

DRIVER CORRECTION DEVICES, AIDS

Operating principle

The system is for detecting an emergency braking situation. In this case, the braking assistance immediately develops maximum power and may trigger ABS regulation.

ABS braking is maintained as long as the brake pedal is applied.



Your braking systems are partially operational. However, it is **dangerous to brake suddenly** and it is essential to stop immediately, as soon as traffic conditions allow. Contact an approved dealer.

Electronic stability program ESC with understeer control and traction control

Electronic Stability Program ESC (depending on the vehicle)

This system helps you to keep control of the vehicle in critical driving conditions (avoiding an obstacle, loss of grip on a bend, etc.).

Understeer control

This system optimises the action of the ESC in the case of pronounced

understeering (loss of front axle road holding).

Traction control

This system helps to limit wheelspin of the drive wheels and to control the vehicle when pulling away accelerating or decelerating.

Deactivating the ESC function

In some situations (driving on very wet ground : snow, mud, etc. or driving with snow chains fitted), the system may reduce the engine output to limit wheelspin.

If this is not required, it is possible to deactivate the function by pressing switch 1.



The warning light on the instrument panel comes on to warn you of this.

If you deactivate this function, the traction control system will also be deactivated.

With the Electronic Stability Program ESC with understeer control and traction control providing additional safety, you are advised not to drive with the function disabled. Correct this as soon as possible by pressing the switch 1 again.

Note : The function is automatically reactivated when the ignition is switched on, or when the speed exceeds (30 mph) 50 km/h.

Operating principle

A sensor in the steering wheel detects the direction selected by the driver.

Other sensors throughout the vehicle measure the actual direction. The system compares driver input to the actual trajectory of the vehicle and corrects the trajectory if necessary by controlling the braking of certain wheels and/or engine power. In the event that the system is en-

gaged, the indicator light  flashes on the instrument panel.

Operating faults

When the system detects an operating fault the warning lights 

and  appear on the instrument panel.

In this case, the Electronic Stability Program ESC with understeer control and traction control are deactivated.

Please consult an authorised dealer if these warning lights remain displayed on the instrument panel after

DRIVER CORRECTION DEVICES, AIDS

the ignition is switched off and on again

Hill start assistance

This function assists the driver when starting on hills. It prevents the vehicle from rolling forwards or backwards by automatically applying the brakes when the driver lifts their foot off the brake pedal to depress the accelerator pedal.

System operation

It only operates when the gear selector is in a position other than neutral (other than **N**) and the vehicle is completely stationary (brake pedal depressed).

The system holds the vehicle for approximately **2 seconds**. The brakes are then gradually released (the vehicle will move according to the slope).



The hill start assistance system cannot completely prevent the vehicle from rolling

backwards in all situations (extremely steep gradients, etc.).

In all cases, the driver may depress the brake pedal to prevent the vehicle from rolling forwards or backwards.

The hill start assistance function should not be used for prolonged stops: use the brake pedal.

This function is not designed to immobilise the vehicle permanently.

If necessary, use the brake pedal to stop the vehicle.

The driver must remain particularly vigilant when driving on slippery or low-grip surfaces and/or on hills.

Risk of serious injury.

TYRE PRESSURE MONITORING SYSTEM

633993

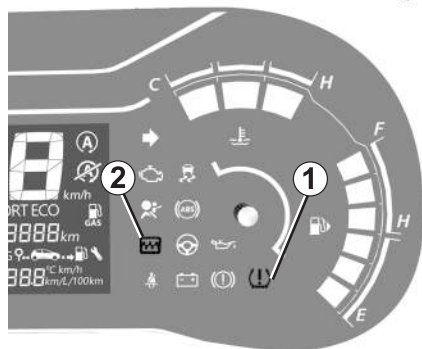

Operating principle

When the ignition switch is in ON position, the low tyre pressure warning light illuminates and then turned off. This indicates that the low tyre pressure warning system is operational.

Warning light  **1** comes on to alert the driver in the event of insufficient pressure (deflated wheel, punctured tyre, malfunction, etc.).

Low tyre pressure warning

If the vehicle is being driven with low tyre pressure  **1** will illuminate.

When the low pressure warning light illuminates you should stop and adjust the tyre pressure to the recom-

mended COLD tyre pressure. The low tyre pressure warning light does not automatically turned off when the tyre pressure is adjusted. After the tyre is inflated the recommended pressure, the vehicle must be driven at speeds above 25 km/h (16MPH) to activate the tyre pressure monitoring system and turn off the low tyre pressure warning light.

TPMS Malfunction :

If the TPMS is not functioning properly the low tyre pressure warning light no **1** will flash for approximately 1 minute when the ignition switch is placed on position. The light will remain on after the 1 Minute along with the electrical warning tell tale no **2**.

Operating conditions

In the following situations, the system risk coming into action late or not functioning correctly :

- system not reset after reinflation or any operation on the wheels.
- system badly reset : different inflation pressures from the recommended pressures.
- significant change in load or distribution of load on one side of the vehicle.
- sporty driving with strong acceleration.
- driving on snowy or slippery surface

- driving with snow chains.
- fitting a single new tyre.
- use of tyres not approved by the network.



This function is an additional driving aid.

The function does not take the place of the driver. It cannot, therefore, under any circumstances replace the vigilance or the responsibility of the driver.

Check the tyre pressures, including the emergency spare wheel, once a month.

3

Resetting the standard level for the tyre pressures

It must be carried out **while the vehicle is stopped**:

- after each reinflation or readjustment of the pressure of one of the tyres.
- when the standard tyre pressure needs to be changed to adapt to usage conditions (empty, carrying a load, motorway driving, etc.).
- after changing a wheel.
- after using the tyre inflation kit.

TYRE PRESSURE MONITORING SYSTEM

– after switching the wheels of the same axle (you must not switch between the front and rear wheels).

It should always be done after checking the tyre pressure of all four tyres when cold.

3

Tyre pressures must correspond to the current usage of the vehicle (empty, carrying a load, motorway driving, etc.).

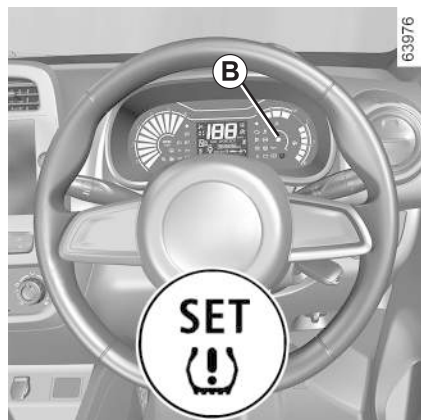



Resetting procedure

Ignition on, **vehicle stationary** :

– press button **B**. briefly several times to select the function "SET TYRE PRESSURE" is displayed on the Instrument panel.

– press and hold (around 3 seconds) button **B** to start initialization. If the

"SET  " warning light flashes or text message in Instrument panel "TPMS ONGOING" for approximately 5 seconds accompanied by a constant illumination of the "SET

 " warning light, this indicates that the request for reinitialization of the tyre pressure reference value has been correctly registered.

Reinitialization is carried out after a few minutes' driving.

Readjustment of tyre pressures

The tyre pressure must be adjusted when the tyres are cold.

If the tyre pressures cannot be checked when the tyres are **cold, the recommended pressures must be increased by 0.2 to 0.3 bar (3 PSI).**

Never deflate a hot tyre.

After each reinflation or readjustment of the tyre pressure, launch the reinitialisation of the tyre pressure reference value.

63993



Inflate tyres and reset

The  1 warning light comes on

along with  2 is displayed in red

This indicates that at least one tyre is flat or punctured.

In the event of a flat tyre, inflate the relevant tyre.

In the event of a puncture, change the tyre or consult an authorised dealer.

It is not recommended to drive the vehicle if a tyre is punctured. This may cause tyre to damage. Refer chapter → 121.

TYRE PRESSURE MONITORING SYSTEM

Check and readjust the pressure of the four tyres when cold, and launch the reinitialization of the tyre pressure reference value. Warning light



1 goes out after launching the reset of the tyre pressure reference value.

Replacing wheels/tyres

Only use equipment approved by the network, otherwise the system risks late activation or incorrect operation.

After each change of wheel/tyre, readjust the tyre pressure and launch the reinitialisation of the tyre pressure reference value.

Emergency spare wheel

If the vehicle is equipped with an emergency spare wheel, it will not have a sensor.

when a spare tire is mounted or wheel is replaced, the TPMS will not function and the low tire pressure warning light will flash for approximately one minute. The light remains on after one minute. contact your authorised dealer as soon as possible for tire replacement.

Tyre repair product and inflation kit

As the valves are specifically designed, only use equipment approved by the network.

System to be checked

Warning light  1 flashes for several seconds, then stays on. This warning light appears along with the



warning light (Applicable for Puncture and sensor failure).

- Puncture  Illuminates as red color continuously.

- Sensor Failure  Illuminates as Orange color approx 70 sec and turned off.

They indicate a system fault. Please consult an authorised dealer.

System unavailable

Warning light  1 flashes for several seconds, then stays on.





TYRE PRESSURE MONITORING SYSTEM

Tyre pressure faults



The table below lists the warning messages which appear on the instrument panel when the system detects a tyre pressure fault.

The information on the instrument panel signals any potential tyre pressure faults (e.g. deflated or punctured tyre).

3

Indicator lights	Messages	Text warning in cluster	Readings
	Adjust Tyre Pressure	RR TYRE PR.LOW RL TYRE PR.LOW FR TYRE PR.LOW FL TYRE PR.LOW	When the tyre pressure loss warning is displayed in Yellow. This indicates that tyre under-inflation has been detected. Check and adjust the pressure of the four tyres then reset the system.
 + 	Puncture	RR TYRE PUNCTURE RL TYRE PUNCTURE FR TYRE PUNCTURE FL TYRE PUNCTURE	When the tyre pressure loss warning is displayed in Yellow and Warning light malfunction are displayed in Red. This indicates that the tyre concerned is punctured or severely under inflated. Adjust the pressure of the four tyres while cold and reset the system if the tyre is deflated. Replace the tyre (or have it replaced) if it is punctured.

TYRE PRESSURE MONITORING SYSTEM

Indicator lights	Messages	Text warning in cluster	Readings
 + 	Check Tyre Pressure Sensors	CHECK RR TPMS CHECK RL TPMS CHECK FR TPMS CHECK FL TPMS	<p>When the tyre pressure loss warning and Warning light malfunction are blinking in Yellow for 70 second approximately.</p> <p>After 70 second, tire pressure loss warning permanently on & warning light malfunction switch off.</p> <p>This indicates the sensor is faulty. Consult an approved dealer.</p>

ENVIRONMENT

Your vehicle has been designed with respect for the **environment** in mind for its entire service life: during production, use and at the end of its life.

This commitment is illustrated by the manufacturer eco² signature.

3

Manufacture

Your vehicle has been manufactured at a factory which complies with a policy to reduce the environmental impact on the surrounding areas (reduction of water and energy consumption, visual and noise pollution, atmospheric emissions and waste water ; sorting and reusing waste).

Emissions

For the usage phase, your vehicle was designed to emit fewer greenhouse gases (CO₂) and therefore to consume less fuel.

Our vehicles are also equipped with a particle filter system including a catalytic converter, an oxygen sensor and an active carbon filter (the latter prevents vapour from the fuel tank being released into the open air).

Please make your own contribution towards protecting the environment too.

- Worn parts replaced in the course of routine vehicle maintenance (vehicle battery, oil filter, air filter, batteries, etc.) and oil containers (empty or filled with used oil) must be disposed of through specialist organisations;
- In all cases, comply with local legislation.

Recycling

Your vehicle is at least 85% recyclable and at least 95% recoverable.

To achieve these objectives, many of the vehicle components have been designed to enable them to be recycled. The materials and structures have been carefully designed to allow these components to be easily removed and reprocessed by specialist companies.

In order to preserve raw material resources, this vehicle incorporates numerous parts made from recycled plastics or renewable materials (vegetable or animal-derived materials such as cotton or wool).

AUTOMATED MANUAL TRANSMISSION

Gear Rotary Shifter 1

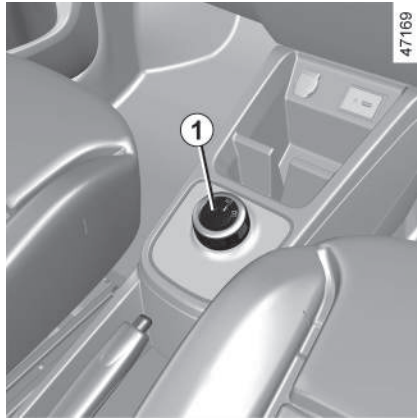

This allows you to engage forward gear, reverse and neutral.



For safety reasons, do not switch off the ignition before the vehicle has come to a complete standstill.

Gear shift pattern

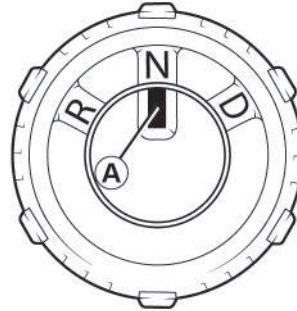

Align the letters R/N/D to the red pointer.

A where **R/N/D** stands for :

D Drive mode.

N Neutral.

R Reverse mode.

NOTE :

- The red pointer is fixed.
- R/N/D is rotating switch.

Display

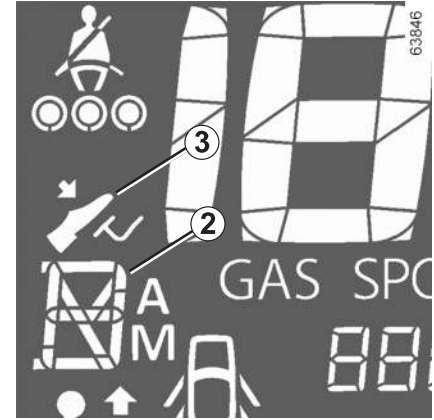

The engaged gear (**R/N/D**) is indicated on the instrument panel display **2**.

In case, gear is not engaged properly, letter **R or D** will blink on the cluster along with buzzer.

This indicates that rotary shifter is not in proper position. Driver advised to shift accordingly.

3 - Brake pedal press warning light.

3

AUTOMATED MANUAL TRANSMISSION



Similar to a vehicle equipped with a manual gearbox, this vehicle is also not able to prevent itself from rolling on a slope if the handbrake is not applied or the brake pedal not pressed continuously in "N" mode.

The vehicle should always be towed in Ignition OFF condition with neutral position. In cold weather start the engine and wait for a few seconds before rotating the gear rotary shifter from **N** to **D/R** position to prevent engine stalling.



Once the vehicle is switched to ignition ON position, the gearbox initializes. This produces a light sound. This is normal. Crank the engine after three seconds.

Starting the engine

Switch ON ignition. To start engine, keep the key in ignition and wait for

3 seconds to initiate starting sequence.

When starting the engine, always place the rotary knob in "**N**" position and **press the brake pedal firmly. The engine cannot be started unless the rotary knob is in "N"** position and brake pedal is pressed. Do not press accelerator pedal while starting the engine.



Start the engine, wait for three seconds before selecting D/R gears. Avoid shifting reverse gear immediately after starting the engine.

Starting off on an uphill/downhill

- Apply parking brake so that vehicle will not move.
- Shift the rotary gear knob to "**D**" while **pressing the brake pedal. Make sure that gear position indicator displays "D"** in cluster.
- Release the brake pedal and press the accelerator gradually. Release the parking brake and continue to press accelerator to start off.

Creeping

Creeping moves the vehicle without pressing the accelerator pedal and helps to control smoothly the motion of vehicle using brake pedal for parking manoeuvre/traffic situations. Creeping is available for forward/reverse directions. Follow as below :

- start the engine as instructed in "starting the engine" section ;
- with the foot on brake pedal, shift the rotary knob to **R/D**.
- release the parking brake and brakepedal to activate creeping.

Creeping will be deactivated if the driver door is not closed properly. While coming from high speeds with brake, creep is not activated until **R** (or 1st gear in manual transmission) engaged.

NOTE

Brake pedal warning light glows if brake pedal is not pressed when,

- Starting the engine.
- Engine ON and rotary knob shifted from **N** to **R/D**.
- Ignition is ON and engine is OFF, rotary knob shifted from **N** to **R/D**.
- Driver door is open and **R/D** is engaged.

AUTOMATED MANUAL TRANSMISSION

Driving in automatic mode

When ignition is switched ON, start the vehicle in neutral **"N"** with **brake pedal pressed, rotate the gear shifter to D** to engage drive mode.

The letter **"D"** appears on the display. The vehicle is controlled using the accelerator and the brake. Gears will change automatically at the optimal moment.

Automatic mode takes account of :

- The position and speed of pressing of the accelerator pedal to assess driving style and select the optimal gear.
- The position and speed of depression of the brake to commence engine braking in preparation for a downshift.
- If the gear does not engage to **R/D** even the rotary knob is shifted, system shifts automatically after some time and creates some noise from gears. This does not indicate any malfunction.

However, if the system does not shift automatically, shift gear knob to **"N"** and again shift to **R/D** in **brake pedal pressed condition. R/D indicator and brake pedal indicator will flash on the cluster if the rotary knob shifted to R/D from N** without pressing the brake pedal.

Reverse gear

With the vehicle stationary and the engine on pressing the brake pedal, rotate the gear shifter to **R**. The letter **R** displays on the cluster. Release the brake pedal slowly to allow vehicle move in the reverse direction. Press the accelerator pedal gently to increase the speed.

The engine idle speed (creeping) is sufficient for parking manoeuvres.

To drive, shift the gear from **R** to **D** by rotating the gear rotary lever once the vehicle is stationary. Press the brake pedal to engage a gear when vehicle is stationary, else, a warning light will come on the cluster.

When stopped at traffic lights, with the gear engaged in **D**, keep the vehicle stationary by continuously pressing the brake pedal without changing the gear shifter to **N**.

The vehicle will move again:

- either slowly, if the brake is released without accelerating (e.g., in a traffic jam);
- or quickly, by releasing the brake and accelerating.



Avoid selecting D/R mode after switching off the engine.

If reverse gear not engaged properly, once the gear shifted from **"N"** to **"R"** position. Then the system will retry to shifting automatically. This will take some time, noise may be heard from gears. This however does not indicate any malfunction.

If still reverse gear not working, and warning buzzer sound along with **"CHECK AUTO GEARBOX"** and depending on the vehicle **"CHECK GEARBOX"** message appears on the cluster, then follow below steps:

With the vehicle stationary, Pressing the brake pedal, rotate the gear shifter:

- shift towards **"N"** position;

and

- again, shift towards **"R"** position.

Now, the reverse gear engaged. once brake pedal released then the vehicle will move in reverse direction.

If any warning light/ message appears in the instrument panel, please contact an approved dealer.

AUTOMATED MANUAL TRANSMISSION

ACTIONS TO AVOID

- Using accelerator pedal to keep the vehicle stationary on an uphill slope while shifting the gear to **R/D**.
- When stopping the vehicle on an uphill grade, do not hold the vehicle by pressing the accelerator pedal. The foot brake pedal should be in pressed condition.

Accelerating and overtaking

- Slowly press the accelerator pedal to accelerate gradually.
- to obtain maximum vehicle performance, press the accelerator pedal quickly and completely.
- the speed with which the accelerator pedal is pressed is directly related to the speed with which the vehicle automatically shifts to a lower gear to accelerate quickly.

Depending on the variant, if the warning message, "GEARBOX OVERHEAT" appears on the cluster when driving, it means the clutch gets overheated and creeping gets deactivated.

To avoid getting the message,

- use parking brake to move the vehicle in slope;
- do not press the brake pedal/accelerator pedal simultaneously for long time;

- do not keep vehicle in standstill in slope using accelerator pedal;

If you are not doing any of above mentioned manoeuvres but the warning message, "GEARBOX OVERHEAT" appears, then contact your dealer.

Parking

To park the vehicle, first bring the vehicle to stationary position.

- If the road is flat, then rotate the gear shifter to N and engage the handbrake and switch off the ignition to complete the parking manoeuvre.
- On a slope, it is recommended to keep the gear shifter in R/D, engage the handbrake and switch off the ignition to complete the parking manoeuvre.

Precautions in Drive mode

- If the vehicle is kept stationary on a slope for too long without applying the brakes or handbrake, it will strain the system and there is a risk that the clutch will overheat.

In this case, an intermittent beeping sound will indicate that the brake pedal or hand brake needs to be applied.

- Never leave the vehicle with the engine running with gear engaged condition.

- A warning light related to brake application will appear on the cluster if brake/handbrake is not applied.

- If engine ON and the vehicle is stationary, it is recommended to keep the brake pedal in pressed condition.

Towing your automated manual transmission vehicle

If the gear is engaged in R/D,

- Switch on the ignition.
- Press brake pedal.
- Select neutral (N).
- Release Brake pedal.
- Check that gear engaged in "N" by ensuring permanent display of letter N in cluster.
- Turn OFF ignition.
- If neutral is not engaged and no indication in cluster, must tow the vehicle with the front wheels raised.

Stopping the vehicle

The vehicle can be stopped by pressing the brake pedal regardless of gear position This is because, clutch is automatically disengaged to prevent the engine from stopping.

PARKING DISTANCE CONTROL

Operating principle

Ultrasonic sensors, fitted in the vehicle's rear bumper, measure the distance between the vehicle and an obstacle when reversing.

This measurement is indicated by beeps which become more frequent the closer you come to the obstacle, until they become a continuous beep when the vehicle is approximately 35 centimetres from the obstacle.

There is a beep when reverse gear is engaged. If the beep sounds for a long time (3 seconds), this signals an operating fault.

NB : ensure that the ultrasonic sensors are not obscured (by dirt, mud, snow, etc.).

Operation



When reverse gear is selected, most objects which are less than approximately 1.20 metres from the rear of the vehicle are detected, a beep sounds,

Operating faults

When the system detects an operating fault, there will be a three-second continuous beep as a warning. Please consult an authorised dealer.



This function is an additional aid that indicates the distance between the vehicle and

an obstacle whilst reversing, using sound signals.

Under no circumstances should it replace the driver's care or responsibility whilst reversing.

The driver should always look out for sudden hazards during driving : always ensure that there are no moving obstacles (such as a child, animal, pram or bicycle, etc.) or small, narrow objects such as stones or posts

REVERSING CAMERA

Operation

3



Depending on the variants, when using reverse gear, the camera 1 sends a view of the area behind the vehicle to the multimedia display 2 together with a static guide line.

This system is used with the aid of a fixed distance gauge. When the red zone is reached, stop the vehicle.



Note: make sure that the reversing camera is not obscured (by dirt, mud, snow, etc.).



This function is an additional aid. It cannot, therefore, under any circumstances replace the vigilance or the responsibility of the driver. The driver should always pay attention to sudden incidents during driving: always ensure that there are no moving obstacles (such as a child, animal, pram, bicycle, etc.) or small, narrow objects such as stones or posts in your path when manoeuvring.

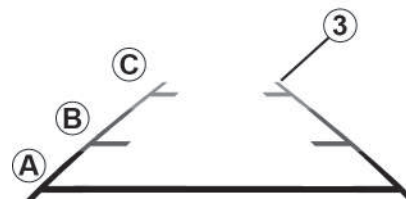

39621

REVERSING CAMERA

Static guide line 3 :

The static guide line **3** has coloured markers **A**, **B** and **C** showing the distance behind the vehicle :

- **A** (red) approximately 30 centimetres from the vehicle ;
- **B** (yellow) approximately 70 centimetres from the vehicle ;
- **C** (green) approximately 150 centimetres from the vehicle.



The screen shows a reverse image.

The frames are a representation projected onto flat ground ; this information must not be taken into account when superimposed on a vertical object or an object on the ground. Objects which appear on the edge of the screen may be deformed.

In very bright light (snow, vehicle in sunshine etc.), the camera vision may be adversely affected.

This gauge remains fixed and indicates the vehicle trajectory if the wheels are in line with the vehicle.

AIR VENTS, AIR OUTLETS

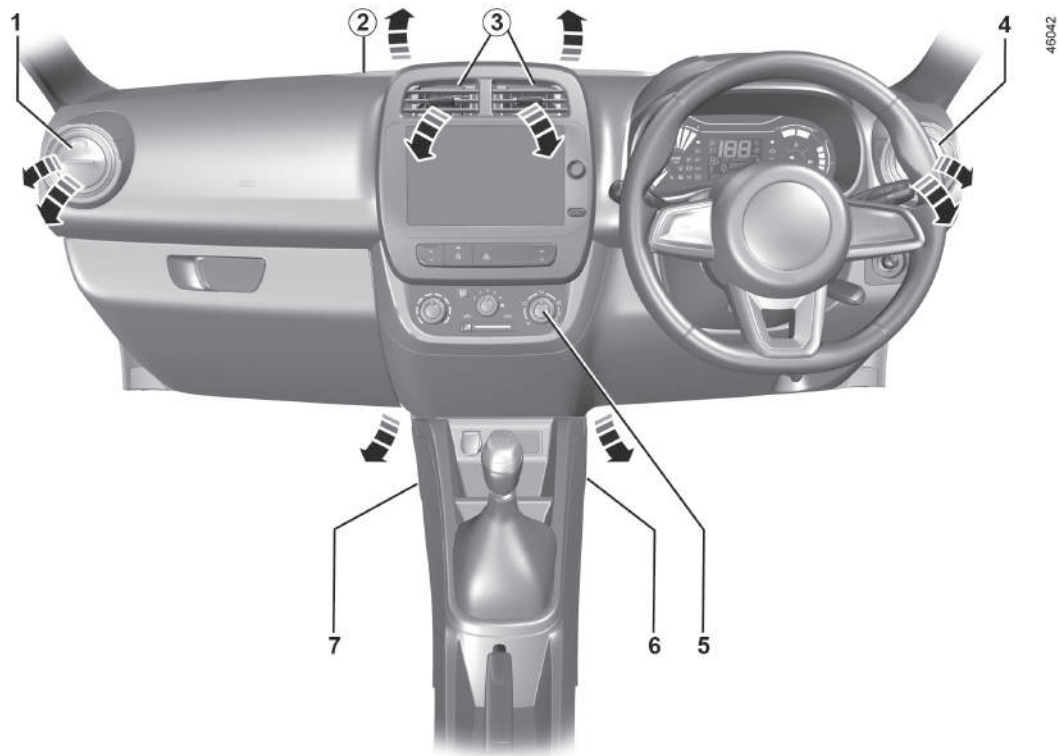

4

AIR VENTS, AIR OUTLETS

1. Left side air vents
2. Windscreen demisting vents
3. Centre air vents
4. Right side vents
5. Control panel
6. Driver footwell heater outlets
7. Front passenger footwell heater outlets

AIR VENTS, AIR OUTLETS

Air flow

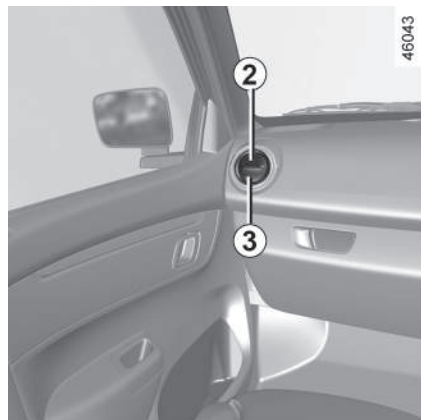

Lateral Air vents (Left and Right)

- To open, press on the groove **2** until it is open as far as required.
- To close, press on the point **3** until it is shut.
- To change Air Flow direction, swivel the air vent to the desired position.

Centre Air Vents



(depends on the vehicle)

- To move the front vanes up/down, move the centre knob **4** upwards/downwards ;
- To open/close the centre vanes (inside the centre knob), move the centre knob **4** towards outside/ innerside respectively ;



Do not add anything to the vehicle's ventilation circuit (for example, to remove bad odours).
There is a risk of damage or of fire.

HEATING, VENTILATION, AIR CONDITIONING

Controls

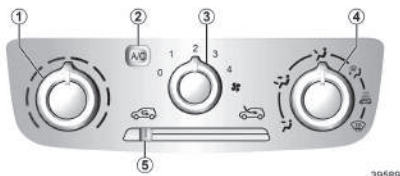

The controls will depend on the vehicle equipment level.

1. Air temperature adjuster.
2. Switching air conditioning on or off.
3. Adjusting the ventilation fan speed.
4. Distribution of Air.
5. Switching passenger compartment to isolation mode / air recirculation mode.

Information and advice on use : refer to information on "Air conditioning : information and advice on use".

Adjusting the air temperature

Turn control **1** to obtain the desired temperature. The further towards the red the slide is, the higher the temperature will be.

Adjusting the ventilation fan speed.

Turn control **3** from 0 to 4. The further to the right it is positioned, the more air is blown into the passenger compartment. If you want to shut off the flow of air completely and stop the system, set control **3** to 0.

The system is deactivated : the ventilation speed for the passenger compartment air is zero (vehicle stationary), you can however still feel a slight flow of air when the vehicle is moving.

i Leaving this control in position 0 for prolonged periods can lead to condensation forming on the side windows and windscreen and problems due to the use of non-renewed air in the passenger compartment.

Switching passenger compartment isolation mode/air recirculation mode on.

Bring lever **5** to position .

Under these conditions, air is taken from the passenger compartment and is recirculated, with no air being taken from outside the vehicle.

Air recirculation is used to :

- to isolate the passenger compartment from the external atmosphere.
- to bring the passenger compartment to the desired temperature as quickly as possible.

Rapid demisting

- Turn control **1** on full hot position.
- Turn control **3** on max speed position 4.
- Turn control **4** to full defrost mode.
- move slider knob **5** to fresh air mode.

Using the climate control increases the speed of demisting.

Information and advice on use : refer to information on "Air conditioning : information and advice on use".

HEATING, VENTILATION, AIR CONDITIONING



Prolonged use of air recirculation can lead to condensation forming on the windscreen, and discomfort due to the use of non-renewed air in the passenger compartment.

You are therefore advised to pick-up external air as soon as the air recirculation function is no longer required, by sliding control **5** to the right.

4



AIR CONDITIONING

Information and advice on use

Fuel consumption

You will normally notice an increase in fuel consumption (especially when driving in town) when the air conditioning is operating.

Advice for reducing consumption and helping to preserve the environment.

Drive with the air vents open and the windows closed.

If the vehicle has been parked in the sun, open the doors for a few moments to let the hot air escape before starting the engine.

Maintenance

Refer to the Maintenance Document for your vehicle for the inspection frequency.

Operating faults

As a general rule, contact your approved dealer in the event of an operating fault.

– Reduction in de-icing, demisting or air conditioning performance.

Contact an approved Renault Dealer.

– No cold air is being produced.

Check that the controls are set correctly and that the fuses are sound. Otherwise, switch off the system.

Presence of water under the vehicle

After prolonged use of the air conditioning system, it is normal for water to be present under the vehicle. This is caused by condensation.



Do not open the refrigerant fluid circuit. The fluid may damage eyes or skin.

WINDOWS

Electric windows

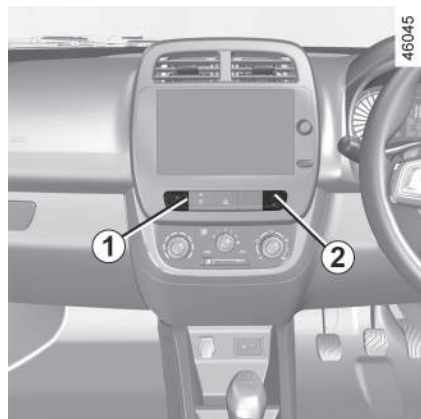

Dashboard switches

Press the bottom of switch **1** or **2** to open the window or press the top of switch **1** or **2** to close it to the desired level.

- 1.** for the passenger side.
- 2.** for the front driver side.



Avoid resting any objects against a half-open window: **there is a risk that the electric window could be damaged.**

Electric windows

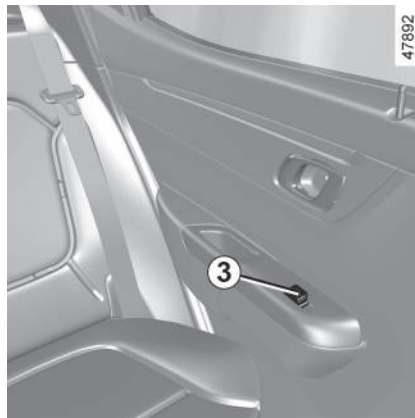

Depending on the variants, use **3** to raise/ lower the rear passenger windows to the desired height.



Driver's responsibility

Never leave your vehicle with the key or remote control in it, leaving a child, adult who is not self-sufficient or a pet inside, even for a short while.

They may pose a risk to themselves or to others by starting the engine or activating equipment (such as the gear lever or electric windows).

If any part of the body becomes trapped, reverse the direction of the window immediately by pressing the relevant switch.

Risk of serious injury.



When closing the windows, ensure that no part of the body (arm, hand, etc.) is protruding from the vehicle.

Risk of serious injury.

WINDOWS

Manual window winders



Depending on the version, turn handle **4** to lower or raise the window to the desired height.

4

SUN VISOR/GRAB HANDLE/INTERIOR LIGHTING

Front sun visor

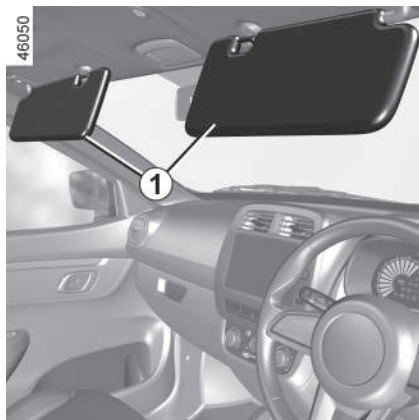

4

This feature depends on the vehicle version.

Lower the sun visor **1** over the windscreen or unclip it and turn it over the side window.

The sun visor **1** has provision for ticket holder.

Rear Grab handle 2



This feature depends on the vehicle version.

This offers support and can be held when the vehicle is being driven.

Do not use it for getting into or out of the vehicle.

- Press switch **3** to position **B** for auto - ON lighting, which activates when a door is opened and switches off when both the front doors have been closed correctly.

Courtesy light

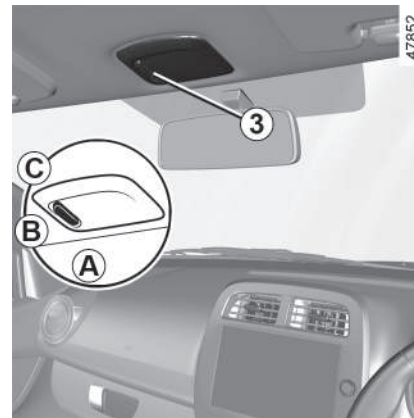

This feature depends on the vehicle version.

3. Press switch to

- position **A** for switching **ON** the light.
- position **B** for auto - ON lighting, which activates when a door is opened and switches off when both the front doors have been closed correctly.
- position **C** for switching **OFF** the light

PASSENGER COMPARTMENT STORAGE

Glove Box 1



Pull handle 1 to open lower glove box

Centre console storage 2

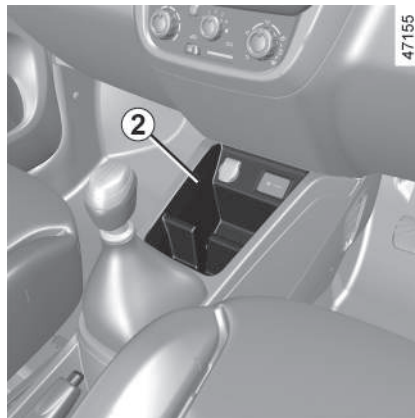

Ticket holder 3

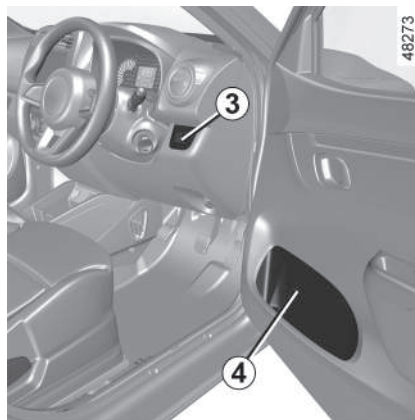

Front door storage 4



Ensure that no hard, heavy or pointed objects are placed in the "open" storage compartments in such a way that they may fall onto passengers during sudden turning, braking or in the event of an accident.

4

ACCESSORIES SOCKET

Accessories socket 1, 3

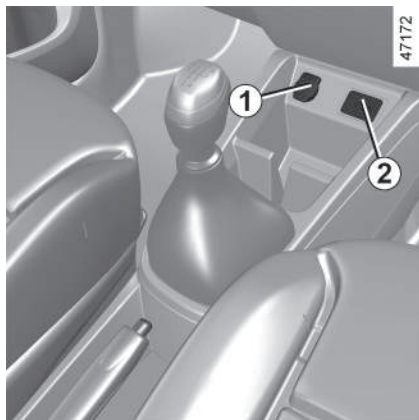

It is provided for connecting accessories approved by our technical department.

USB / Aux port 2

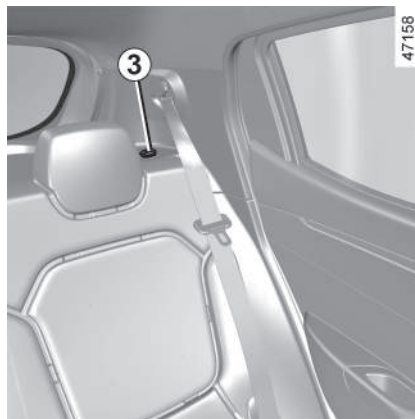

Connect accessories with a maximum power of 120 watts (12 V) only. When several accessory sockets are used at the same time, the total power of the connected accessories must not exceed 180 watts.

Fire hazard.

REAR SEATS

To fold the backrest

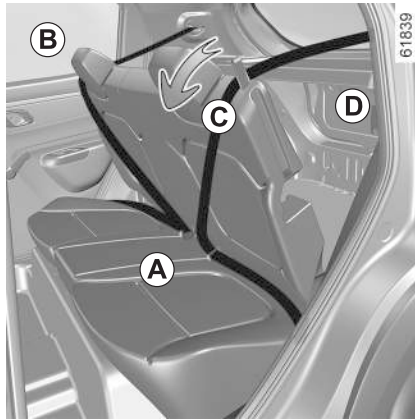

Before folding down a seatback:

- Lower the headrest fully.
- During folding, left and right seat belts must be positioned and seat belts should be buckled to the cushion buckles in order to protect seat belt jamming between seat back and latch.
- Hold straps **B** and **C** and pull them together to unlatch the seatback.
- Hold the seatback and pull down towards **A**,

Refitting the seatback

- Lower the headrest fully.

- During unfolding left and right seat belts must be positioned and seat belts should be buckled to the cushion buckles in order to protect seat belt jamming between seat back and latch.
- Push the seatback toward **D** and ensure both latches locked properly

 Allow the seatback turn on its axis naturally without forcing it, guiding it as it lowers onto the seat base.

 When moving the rear bench seat, ensure that nothing obstructs the anchorage points (part of the body, a pet, gravel, cloth, toys, etc.).



When refitting the seatback, make sure it is correctly locked in place.

If seat covers are fitted, make sure these do not prevent the seatback latch from locking in. Make sure that the seat belts are positioned correctly. Check that the rear seat belts are positioned and operating correctly each time the rear seat is moved.

Never allow anyone to ride in the luggage area or on second row seat when it is in the fold-down position. Use of these areas by passengers without proper restraints could result in serious injury in an accident or sudden stop.

Properly secure all luggage to help prevent it from sliding or shifting. Do not place luggage higher than the backrest. When operating the backrest, be careful not to scratch or damage seat belts.

BOOT

To open



From the outside

Insert the key in the tail gate lock **1**, turn it and lift the boot lid.



From the inside

Pull the lever **2**, then lift the boot lid. Once the tail gate is opened, you can access parcel shelf **A**. Parcel shelf is made of one rigid section.

Gently, lift the parcel shelf and pull towards you by holding it at each end.

To close

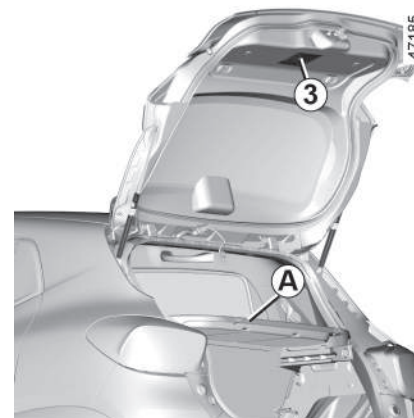

Lower the tail gate from point **3** using your hands and properly close it.

LONGITUDINAL ROOF BARS



Depending on the vehicle, it is equipped with longitudinal style roof bars **1** These roof bars are meant only for aesthetic purpose and do not carry any load.



For information on the range of equipment adapted to your vehicle, we advise you to consult an approved dealer. Refer to the manufacturer's instructions on how to fit and operate the equipment.

MULTIMEDIA EQUIPMENT

4



The presence and location of this equipment depends on the vehicle's version and multimedia equipment.

1. Radio or navigation system.
2. Microphone.



- In all cases, it is very important to follow the manufacturer's instructions carefully.

- The specifications of the brackets and wires (available from our network) vary depending on the equipment level of your vehicle and the type of radio.

Consult your approved Dealer to find out the correct part number.

- No work may be carried out on the vehicle's electrical or radio circuits, except by approved Dealers: an incorrectly connected system may result in damage being caused to the electrical equipment and/or the components connected to it.

Hands-free telephone integrated control



On equipped vehicles, use microphone **2**.

If your vehicle is not fitted with an audio system, one can be fitted and locations have been provided for the radio **1**.

To install any equipment, please consult an authorised dealer.

Refer Multimedia manual for more details.

MULTIMEDIA EQUIPMENT



Using the telephone

We remind you of the need to conform to the legislation in force concerning the use of such equipment.



To use this equipment, consult the instructions for the equipment which should be kept with the other vehicle documentation.

Steering wheel controls



On equipped vehicles, use:

- **3** select the audio source.
- **4** Scroll to navigate the list with press function.
- **5** Volume decrease "-".
- **6** Volume increase "+".



- **7** Mute.
- **8** Answer the call/call attend.

RADIO EQUIPMENT

Radio equipment : use

61838

4

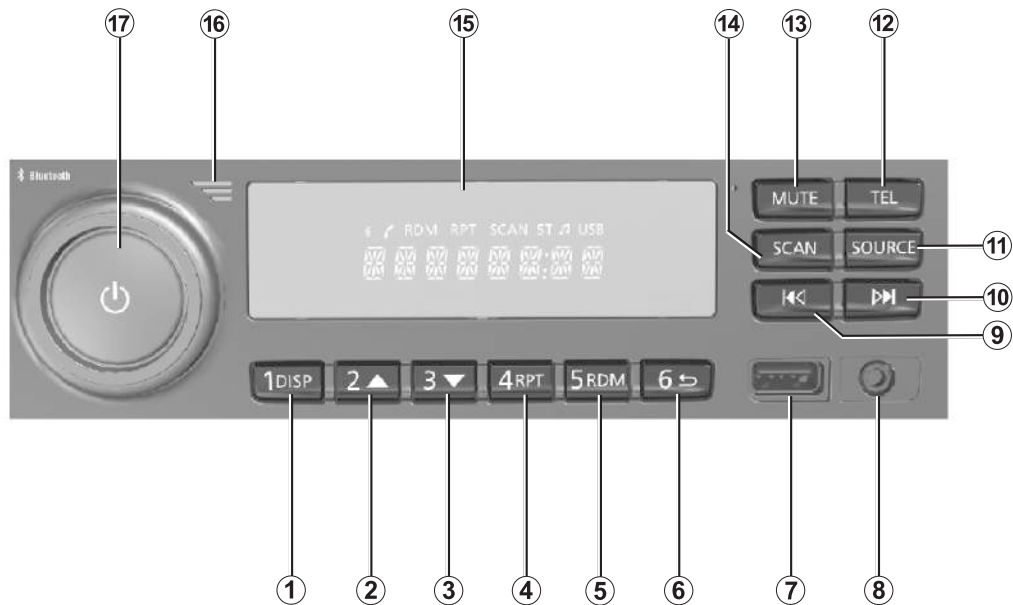

RADIO EQUIPMENT

It is essential to follow the precautions in following pages when using the system, both in the interest of safety and to prevent material damage. User must always comply with laws of the country in which user are travelling.

- 1** Displays the artists of tracks / FM tuned in / Preset station 1 for FM
- 2** Select previous folder from the auxiliary storage/ Preset station 2 for FM
- 3** Select next folder from the auxiliary storage/ Preset station 3 for FM
- 4** Repeat a track/ Preset station 4 for FM
- 5** Selection of tracks at random/ preset station 5 for FM-Random
- 6** Exits to main menu / previous track/ Preset station 6 for FM
- 7** Play Music from auxiliary source via USB port
- 8** Play Music from auxiliary source via AUX port
- 9** Select next track or fast forward or change to next station
- 10** Select the Required connected medium
- 11** Answer a call
- 12** Select previous track or fast rewind or change to previous station
- 13** Mute the volume / Pause & play depending on the mode
- 14** Search for stations in a given band
- 15** Display - Vacuum Fluid Display (VFD)
- 16** Mic for answering calls
- 17** Power ON or OFF push button / Source Volume control

RADIO EQUIPMENT



Precautions concerning the equipment

Do not attempt to dismantle or modify the system as there is a risk of damage to equipment and fire.

Contact approved dealer in the event of malfunction and for all operations involving disassembly.

Do not stick paper to the radio. After prolonged use remove the USB key.

Precautions using the phone

There are laws which govern the use of phones in vehicles. They do not necessarily authorise the use of hands-free phone systems under all driving conditions: drivers must be in control of their vehicles all the times.

Using a phone whilst driving is a significant distraction and risk factor during all stages of use (dialling, communicating, searching for a number in handset memory etc.)

Precautions when operating the audio system

Operate the controls (on the dash or near the steering wheel) and read the information on the screen only when road conditions allow.



RADIO EQUIPMENT

Introduction

The audio system comprises of the following functions:

- USB
- Bluetooth hands-free phone system
- Radio(AM,FM with RDS)

Auxiliary audio function

User can listen stereo directly through vehicle's speaker. There are several ways of connecting user's personal stereo, depending on the type of device user has and the vehicle offers:

- USB socket
- Jack socket
- Bluetooth connection

For more information on compatible devices, contact an approved dealer.

Hands-Free function

The hands-free Bluetooth system provides the following function without having to handle user's phone:

- Receive a call
- Reject a call
- Hold and unhold

This function also enables the user to listen to audio files via hands-free Bluetooth function.



User's Hands-free system is only intended to communication by reducing the risk factors, without removing them completely. User must comply with laws of the country in which travelling.

Radio (AM, FM with RDS)

The radio enables FM radio to be played by short pressing button 17(Power push button). The radio stations are classified by wavelength:

- FM(frequency modulation) and
- AM(amplitude modulation)

The RDS radio system enables the names of certain stations to be displayed if it is broadcasted by FM radio stations.

Set the volume to a reasonable level so that outside noise can be heard



Precautions concerning the equipment

Do not attempt to dismantle or modify the system as there is a risk of damage to equipment and fire. Contact approved dealer in the event of malfunction and for all operations involving disassembly.

Do not stick paper to the radio. After prolonged use remove the USB key.

Using a phone whilst driving is a significant distraction and risk factor during all stages of use (dialling, communicating, searching for a number in hand-set memory etc.)

Precautions when operating the audio system

Operate the controls (on the dash or near the steering wheel) and read the information on the screen only when road conditions allow.

RADIO EQUIPMENT

Switching On and Off

Short Press **17** to switch on user's radio system. The audio system can be used with ignition off. It will run till the battery lasts. Switch off the radio by long pressing **17**.

Source Selection

User can choose from various sources by short press the button **10**.

Volume Controls

Adjust the volume by rotating button **17** either clockwise or anti-clockwise directions.

The displays shows volume setting value (from 00 to 36)

Increase the volume by rotating in clockwise direction

Decrease the volume by rotating in anti-clockwise direction

Mute Function

The Mute function can be enabled by pressing the button **13**.

To continue to listen press same button briefly.

User can Play or pause using the same button when radio is connected to Auxiliary devices via. USB or AUX port (button no **7** and **8**)

Listening to Radio

Press button **10** to choose from FM - 1 FM - 2 or AM.

FM 1 - stores the first 6 channels in the band automatically.

FM 2 - stores the next 6 channels in the band automatically.

AM -Amplitude Modulated wave band

Selecting a radio station

There are different modes for choosing a radio station.

1 Automatic search - It allows stations to be searched automatically scanning the selected band.

To access the station, press button **13**.

stop search short press button **13**.

2 Manual search - This mode allows user search for stations manually by scanning the selected waveband.

To access the stations, press and hold button **9**. Release button **9** to refine the search step by step.

In case of AM band the frequency increase or decrease by 9 KHz.

Storage of Radio stations

This operating mode allows user to listen to the radio stations that user have previously stored on demand.

Select a waveband, and then select a radio station using the modes described previously.

To store a station, press one of the buttons from 1 to 6 to store it in desired position.

It is possible to store 6 stations per waveband (FM 1, FM 2, or AM).

To recall the stored station, press one of the buttons from **1** to **6**.

Listening to the Radio

When listening to the radio, briefly press button **13** to activate the auto store mode. The radio returns to the last Auto stored station played. User can select user's choice of station by using buttons from **1** to **6**.

RADIO EQUIPMENT



Some buttons (from 1 to 6) may not correspond to a radio station if the automatic search

function has found fewer than 6 six stations.

The best reception will be programmed as channel 1 and can be selected by pressing button **1**.

AF-RDS (Radio Data System) automatic returning

The frequency of an FM station changes according to the geographical area. Certain stations use the RDS system which allows automatic returning. The radio system is able to follow the changes in frequency of these stations.

Auxiliary audio sources

User's audio system has an auxiliary input port and a USB port to connect to external audio sources (Bt. portable audio sources, MP3 player).

There are several ways to connect user's portable audio player,

- USB Socket
- AUX port

- Bluetooth connection



The auxiliary audio sources formats can be MP3, WMA.

AUXILIARY INPUT: USB Socket Connection

Connect the audio device to the USB socket through USB key.

Once the device's connector has been connected to the USB port, the track being played is displayed automatically. Each press of (preset1) button **1** in USB will display the options File, Folder, Artist, Album, Title and the last selected from the list shall display in the display when the track is playing.

Each press of button **4** in USB shall guide through Repeat Track, Repeat Folder, Repeat All options.

Each press of button **5** in USB shall guide through Random Folder, Random All, Random Off options.



If this is the first connection to the system, audio playback will begin with the first track

from the folder of the source. Otherwise, playback will begin at the last track (if user is connecting the same device two consecutive times). Maximum storage limit of the device supported shall be 64Gb. Once connected, user can no longer directly control user's portable digital audio player. User must use the buttons on the front panel of the audio system.

Only handle the personal stereo when traffic conditions permit. Store the portable audio player safely while driving (risk of being thrown in the event of sudden braking or impact).

The number of accessible function varies depending on the type of portable audio player and its compatibility with the audio system.

RADIO EQUIPMENT

If the AUX system is disconnected then the system returns to the previous menu.
No options are available for selecting a particular track or folder in Bluetooth Audi mode.

4 Making or Receiving a call

The phone calls can be accessed from user's radio once it has been paired with user device.

User can pick the call in a single go. With the help of the speakers and mic user can make calling experience more comfortable.

Similarly user can make a call in a single go with the help of user's phone, mic and speakers conveniently.

The system supports holding calling when user's telephone is connected.

If user receives a call when user is on another call, this new call can be put on hold.

User can switch between hand phone and speaker by using button **6**. User can hold first call and accept second call using button **7** or user can disconnect second call and resume first call using same button **7**. User can receive a call by short

pressing button **17** Connection Failure.

In any case the key position is changed to off condition and radio gets switched off while user is on a call. The call gets automatically transferred to user's phone and user can call using user's hands free like a normal mobile.

Audio Settings

Radio gives access to settings for the music user listen to, by short pressing button **7** and selecting the features by turning the volume button and selecting the centre button for final selection of the value for the particular selected setting.

The various features supported by radio are as follows,

- Bass
- Treble
- Fader (front /rear balance)
- Balance (left/right balance)

Equalizer pre-sets such as Pop, Rock, Jazz, Soft, Classic, Voice.

User can modify the value of each setting by turning the volume wheel button **17** either clockwise or anti-clockwise directions.

The display indicates the type of setting user has selected and the value users have set for the setting.

The system exits once user short press the button **6** (ESC button).



It is recommended that user stop user's vehicle before entering a number or searching for a contact User's hands-free phone system is only intended to facilitate communication by reducing the risk factors, without removing them completely. User must always comply with the laws of user's country in which user is travelling.



Audio settings are applicable to Bt. streaming or any audio device connection via. Bt. Except folder selection and track selection and is independent of the radio.

Radio Settings

The radio channels can be selected from a given bandwidth either by

RADIO EQUIPMENT

manual tuning mode or the first 6 channels are stored automatically. And the user can access them using buttons from 1 to 6 respectively. If the user tunes to a particular favourite channel the same can be saved in the channels and can be accessed using the same buttons i.e., 1 to 6.

Phone Settings

User can exit a call or attend a call by selecting the button **11** provided users have paired user's phone via. Bluetooth.

Bluetooth Settings

The bluetooth audio settings can be set by the user themselves. User can activate/ deactivate the bluetooth function by pairing user's device with the radio system.

Connecting Bluetooth:

- Press Telephone Button **11**
- Display shows BT ON, means the Bluetooth is in OFF state. Press the button **17** (Power) to switch ON the bluetooth
- Rotate **17** (Volume control) to activate audio Bluetooth
- Your mobile gets connected with audio device

- Your mobile phone will prompt for a passcode. Type "1234" to pair

The various settings supported by Bluetooth audio streaming are Bass, Treble, Fader (front/rear), Balance (left/ right)

User can activate or deactivate the Bluetooth function by pairing user's device with the radio system

BONNET

5

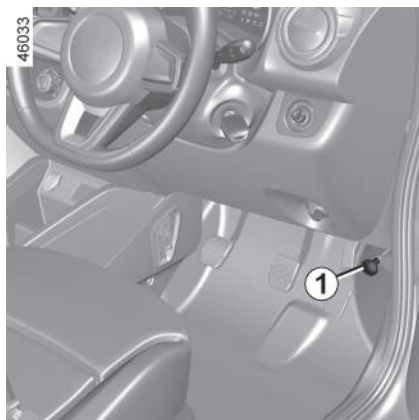

To open the bonnet, pull the knob **1**.

Unlocking the bonnet latch

To unlock, gently lift the bonnet and push tab **2** towards left to release the latch **4**.

Opening the bonnet

Lift the bonnet ; remove the Hood-Stay rod **3** from lock clip from the hood and place into the hole to hold the Hood open.

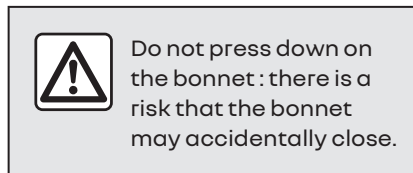

Do not press down on the bonnet : there is a risk that the bonnet may accidentally close.

Closing the bonnet

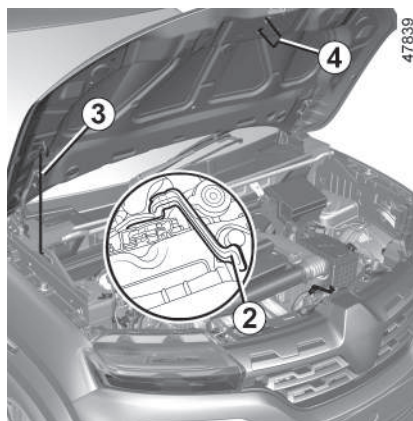

To close the bonnet again, remove the Hood-Stay rod **3** from the hole and place to the lock clip. Lower it to 30 cm above the closed position, then release it. It will latch automatically under its own weight.



The engine may be hot during operations in close proximity. In addition, the engine cooling fan may come on at any moment.
Risk of injury.



In the event of even a slight impact involving the radiator grille or bonnet, have the bonnet lock checked by an approved Dealer as soon as possible.



When working in the engine compartment, ensure that the windscreen wiper stalk is in the park position.
Risk of injury.

BONNET



Ensure that the bonnet is properly locked.
Ensure that nothing is preventing locking (grit, cloths, etc.).



Make sure nothing is left in the engine compartment (cloth, tools, etc.).
These may damage the engine or cause a fire.

ENGINE OIL LEVEL

Topping up, filling

It is normal for an engine to use oil for lubrication and cooling of moving parts and it is normal to top up the level between oil changes.

However, contact your approved Dealer if more than 0.5 litres is being consumed every 1,000 kms after the running in period.

5

Oil change frequency : check the oil level from time to time and certainly before any long journey to avoid the risk of damaging your engine.



In order to prevent splash-back, it is recommended that a funnel be used when topping up/filling with oil. Consult your approved dealer at once if you notice an abnormal or repeated drop in any of the fluid levels.

Reading the oil level

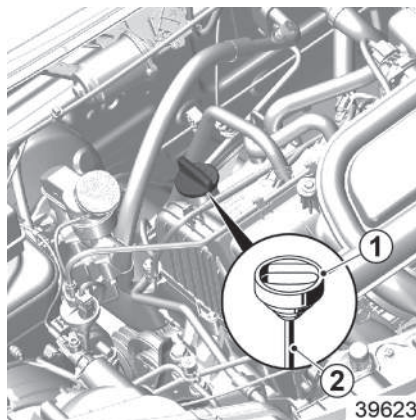

- Remove the dipstick and wipe with a clean, lint-free cloth.
- Guide the dipstick in as far as it will go (for vehicles equipped with a cap-type dipstick, screw the cap in as far as it will go).
- Take out the dipstick again.
- Read the level : it should never fall below minimum mark or exceed maximum mark.

Once the operation has been completed, ensure that the dipstick is guided in as far as it will go or that the "cap-type dipstick" is completely screwed in.



Exceeding the maximum engine oil level

Under no circumstances must the maximum fill level be exceeded : risk of damage to the engine and catalytic converter.
If the oil level exceeds the maximum level, **do not start your vehicle** and contact an approved Dealer.



Before performing any action in the engine compartment, the ignition must be switched off by pressing the engine stop button (please see the information on "Starting, stopping the engine" in **➔ 58**).

ENGINE OIL LEVEL

Topping up/Filling

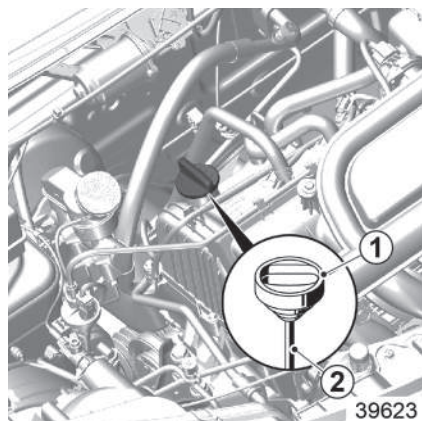

The vehicle must be parked on level ground and the engine should be cold (for instance, before the engine is started up for the first time in the day).

 Do not exceed the **max** level and do not forget to refit cap **1**.

- Unscrew cap **1**.
- top up the level (as a guide, the capacity between the minimum and maximum reading on the dipstick **2**

is approximately 0.85 litres, (depending on the engine).

- wait for approximately 20 minutes to allow the oil to flow into the engine.
- check the level using the dipstick **2** (as described above).

Once the level has been read, ensure that the "cap-type dipstick" is completely screwed in.

 In order to prevent splash-back, it is recommended that a funnel be used when topping up/filling with oil.

 Consult an approved dealer at once if you notice an abnormal or repeated drop in any of the fluid levels.

 Never run the engine in an enclosed space as exhaust gases are poisonous.



The engine may be hot during operations in close proximity. In addition, the engine cooling fan may come on at any moment.
Risk of injury.



Engine oil change : if you are changing the oil when the engine is hot, be careful not to scald yourself if the oil overflows.

5

Oil change

Service interval : refer to the Maintenance Document for your vehicle.

Oil change capacity

Please refer to the maintenance document for your vehicle, or contact an authorised dealer.

Always check the engine oil level using the dipstick, as explained previously (it should never fall below the minimum).

ENGINE OIL LEVEL

Engine oil grade

Refer to the maintenance document for your vehicle.

5



Exceeding the maximum engine oil level

The oil level should only be read with the dipstick as explained above. If the oil level exceeds the maximum level, **do not start your vehicle** and contact an approved dealer.



Filling and/or Checking the oil level :

Take care when topping up or checking the oil level. Make sure that no oil drips onto engine components. Remember to refit the cap securely, and put the dipstick back in place to avoid oil splashes onto hot engine components.

Fire hazard.

LEVELS

Brake fluid level

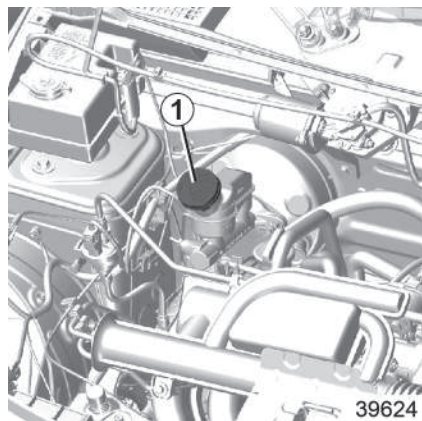

The level should be read with the engine switched off and on level ground. This should be checked frequently, and immediately if you notice even the slightest loss in braking efficiency.



If there is an abnormal or repeated drop in the fluid level, please consult an authorised dealer.

Level 7

It is normal for the level to drop as the brake shoes become worn, but it must never drop lower than the "MINI" warning line.

If you wish to check the disc and drum wear yourself, you should obtain the document explaining the checking procedure from the network or the manufacturer's web site.

Topping up

After any operation on the hydraulic circuit, a specialist must replace the brake fluid. Only use fluids approved by our Technical Department (and taken from a sealed container).

Replacement interval

Refer to the Maintenance Document for your vehicle.



For your safety, do not remove the bonnet holding straps.

Risk of the bonnet falling on the road surface.

Windscreen washer reservoir

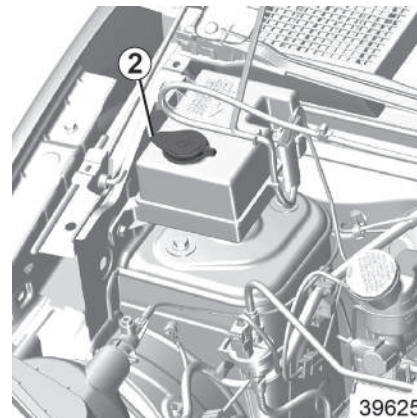

5

Topping up

Engine switched off :

- open the cap **2** ;
- pull the extending funnel upwards as far as it will go ;
- fill until you can see the fluid ;
- push the funnel by pressing on it and replace the cap.

Liquid

Only use Windscreen washer fluid containing antifreeze. We advise you to consult an authorised dealer or a qualified professional.

LEVELS

 Do not use hard water (risk of damage to the priming pump, limescale building up on the pump and the jets)

Jets:

To adjust the height of the wind-screen washer jets, please consult an authorised dealer.

5

Coolant level

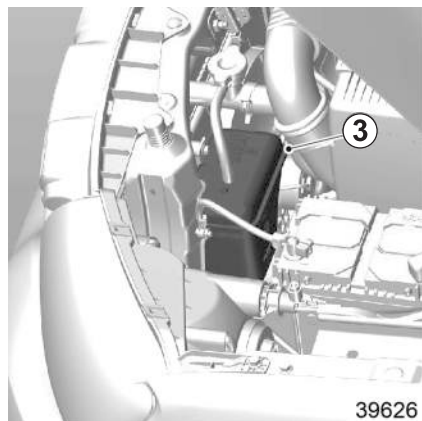

39626

Check the level on flat ground, with the engine switched off. **When cold**, the level must be between the MINI and MAXI marks on the reservoir **3**.

Top this level up when cold before it reaches the MINI mark.



No operations should be carried out on the cooling circuit when the engine is hot.

Risk of burns.

Checking intervals

Check the coolant level regularly (very severe damage is likely to be caused to the engine if it runs out of coolant).

If the level needs to be topped up, only use products approved by our Technical Department which ensure:

- protection against freezing.
- anti-corrosion protection of the cooling system.

Replacement intervals

Refer to the Maintenance Schedule for your vehicle.



When working in the engine compartment, ensure that the wind-screen wiper stalk is in the park position.

Risk of injury.



Consult an approved dealer at once if you notice an abnormal or repeated drop in any of the fluid levels.

Filters

The replacement of filter elements (air filter, cabin filter, fuel filter, etc.) is scheduled in the maintenance operations for your vehicle.

Replacement intervals for filter elements: please refer to your vehicle's maintenance schedule.

LEVELS



Before carrying out any action in the engine compartment, you must switch off the ignition.



The engine may be hot during operations in close proximity. In addition, the engine cooling fan may come on at any moment.
Risk of injury.

BATTERY

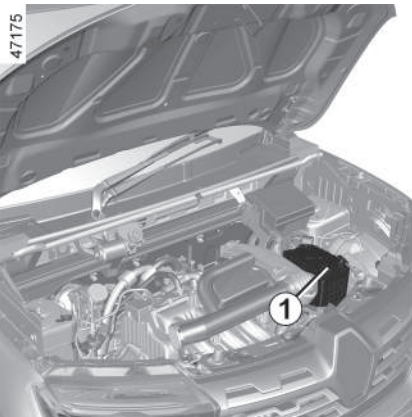

5

The battery **1** does not require any maintenance. **You must not open it or perform any added liquid.**



The engine may be hot during operations in close proximity. In addition, the engine cooling fan may start at any moment.

Risk of injury.



Handle the battery with care as it contains sulphuric acid, which must not come into contact with eyes or skin. If it does, wash the affected area with plenty of water and see a doctor if necessary. Ensure that naked flames, red hot objects and sparks do not come into contact with the battery as there is a risk of explosion.

The charge status of your battery can decrease especially if you use your vehicle :

- for short journeys.
- for driving in town.
- when the temperature drops.
- after extended use of consumers (radio etc.) with the engine switched off.

Replacing the battery

As this operation is complex, we advise you to contact an approved Dealer.

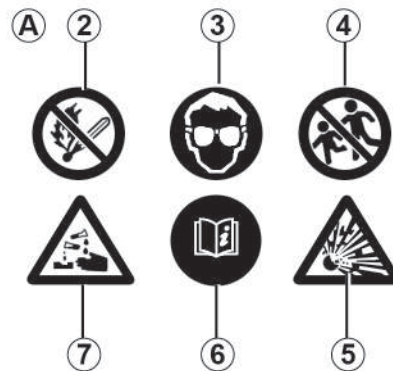

Label A

Observe the indications on the battery :

- **2** Naked flames and smoking are forbidden.
- **3** Eye protection required.
- **4** Keep away from children.
- **5** Explosive materials.
- **6** Refer to the handbook.
- **7** Corrosive materials.

TYRE PRESSURE

Adhere to the tyre pressures (including the emergency spare wheel). The tyre pressures should be checked at least once a month and additionally before any long journey.

Tyre pressures should always be checked when the tyres are cold, ignore higher pressures which may be reached in hot weather or following a fast journey.

If the tyre pressures cannot be checked when the tyres are cold, increase the pressures from 0.2 to 0.3 bar (or 3 PSI).

never deflate a hot tyre.

Refer the table for the Tyre Pressure in your vehicle.

A label of the tyre pressure details is pasted on the driver door of the vehicle.

Tyre Location	Un-Laden Condition	Laden Condition
Front	A	B
Rear	C	D
Spare Wheel	E	

A : un-laden condition for front tyre pressure.

B : laden condition for front tyre pressure.

C : un-laden condition for rear tyre pressure.

D : laden condition for front tyre pressure.

E : tyre pressure for spare wheel.

Special note concerning fully laden vehicles : the maximum speed must be limited to 100 kph.



Incorrect tyre pressures lead to abnormal tyre wear and unusually hot running. These

are factors which may affect safety and lead to poor road holding,

- risk of bursting or tread separation.
- The pressure depends on the load and the speed of use. Adjust the pressure according to the conditions of use.
- Please be aware that a poorly tightened or missing valve cap can make the tyres less airtight and lead to pressure loss.
- Always use valve caps identical to those fitted originally and tighten them fully.

BODYWORK MAINTENANCE

A well-maintained vehicle will last longer. It is therefore recommended to maintain the exterior of the vehicle regularly.

Your vehicle has been treated with very effective anti-corrosion products. It is nevertheless subject to various outside influences.

Corrosive agents in the atmosphere

- atmospheric pollution (in built-up and industrial areas);
- saline atmospheres (near the sea, particularly in hot weather);
- seasonal and damp climatic conditions (e.g. road salt in winter, water from road cleaners, etc.).

Minor impacts

Abrasive action

Dust and sand in the air, mud, road grit thrown up by other vehicles, etc. You should take a number of minor precautions in order to safeguard your vehicle against such risks.

You should do the following

Wash your car frequently, **with the engine off**, with cleaning products recommended by our Technical Department (never use abrasive products). Rinse thoroughly beforehand using a jet washer:

- spots of tree resin and industrial pollution;
- mud in the wheel arches and underneath the body which forms damp patches;
- **bird droppings, which cause a chemical reaction with the paint that rapidly discolours paintwork and may even cause the paint to peel off;**

wash the vehicle **immediately** to remove these marks since it is impossible to remove them by polishing;

- salt, particularly in the wheel arches and underneath the body after driving in areas where the roads have been gritted.

Remove the vegetable falls (resin, film etc.) from the vehicle regularly.

Observe the vehicle stopping distances when driving on gravelled surfaces to prevent paint damage.

Repair, or have repaired quickly, areas where the paint has been damaged, to prevent corrosion spreading.

Remember to visit the body shop periodically in order to maintain your anti-corrosion warranty. Refer to the Maintenance Document.

Respect local regulations about washing vehicles (e.g. do not wash your vehicle on a public highway).

When washing the vehicle with a highpressure cleaning device, please take the following precautions:

- make sure that your vehicle's paintwork, the area or the component that you want to clean is compatible with this type of washing;
- the pressure delivered by the device must be less than 100 bar;
- when washing, position the spray nozzle at least 15 cm from the vehicle and check that the water flow rate is less than 15 l/min (3.30 gal);
- do not persist in washing the same area, impacted points or the seals (risk of damage to the paint, seals becoming detached, etc.).

If mechanical components, hinges, etc. have been cleaned, they must be protected again by spraying with products approved by our Technical Department.



We have selected special products to care for your vehicle and you can obtain these from the manufacturer's accessory outlets.

BODYWORK MAINTENANCE

Do not do the following

Wash the vehicle in bright sunlight or freezing temperatures.

Do not scrape off mud or dirt without pre-wetting.

Allow dirt to accumulate on the exterior.

Allow rust to form following minor impacts.

Using solvents not approved by our Technical Department to remove stains as this could damage the paintwork.

Do not drive in snow or muddy conditions without washing the vehicle, particularly under the wheel arches and body.



Degrease or clean using high-pressure cleaning equipment or by spraying on products not approved by our Technical Department:

- mechanical components (e.g. : engine compartment);
- underbody;
- parts with hinges (e.g. : inside the doors);
- painted plastic external fittings (e.g. : bumpers).

Doing this could give rise to corrosion or operational faults.

Vehicles with a matte paint finish

This type of paint requires certain precautions.

You should do the following

Wash the vehicle by hand using plenty of water, using a soft cloth or a gentle sponge.

Do not do the following

Use wax-based products (polishing).

Rub too hard.

Wash the vehicle in a roller-type car wash.

Attach stickers to the paintwork (risk of leaving marks).



Wash the vehicle using a high-pressure cleaning device.

Using a roller type car wash

Return the wiper stalk to the park position ➔ 53. Check the mounting of external accessories, additional lights and rear view mirrors, and ensure that the wiper blades are secured with adhesive tape.

Remove the radio aerial mast if your vehicle is fitted with this equipment.

Remember to remove the tape and refit the antenna after washing.

Cleaning the headlights, sensors and cameras

Use a soft cloth or cotton wool. If this does not clean them properly, moisten the cloth with soapy water, then wipe clean with a soft damp cloth or cotton wool.

Finally, carefully dry off with a soft dry cloth.

Do not use cleaning products containing alcohol or utensils (e.g. : a scraper).

Cleaning stickers, decorative films, etc.

You should do the following

Use a soft cloth or cotton wool.

Moisten it slightly with soapy water then always wipe clean with a soft cloth or cotton wool.

Finally, carefully dry off with a soft dry cloth.

Do not do the following

Use alcohol-based cleaning products.

Use utensils (e.g. a scraper).

BODYWORK MAINTENANCE

Rub too hard.



Wash the vehicle using a high-pressure cleaning device.

5



INTERIOR TRIM MAINTENANCE

A well-maintained vehicle will last longer. It is therefore recommended to maintain the interior of the vehicle regularly.

A stain should always be dealt with swiftly.

Whatever type of stain is on the trim, use **cold (or warm) soapy water with natural soap**.

Detergents (washing-up liquid, powdered products, alcohol-based products) should not be used.

Use a soft cloth.

Rinse and soak up the excess water.

Multimedia screen

Maintenance of the screen may depend on the type of multimedia equipment. Please refer to the multimedia instructions for further information.

Glass instrument panel

temperature display, radio display, etc.)

Use a soft cloth or cotton wool.

If this does not clean them properly, use a soft cloth (or cotton wool) slightly moistened with soapy water and then wipe clean with another soft damp cloth or cotton wool.

Finally, carefully dry off with a soft dry cloth.

Do not use products containing alcohol and/or spray fluids on the area.

instrument panel

(e.g. instrument panel, clock, exterior temperature display, radio display, etc.)

Use a soft cloth (or cotton wool).

Caution :

No liquid cleaning agents and water should be used to clean the Instrument panel.

It is recommended to use only soft and dry cloth to clean the instrument panel as there is no glass screen on the same.

Cleaning products containing alcohol must not be used under any circumstances.

Seat belts

These must be kept clean.

Use products selected by our Technical Department (Approved outlets) or warm, soapy water and a sponge and wipe with a dry cloth.

Detergents or dyes must not be used under any circumstances.

Textiles (seats, door trim, etc)

Vacuum-clean the textiles **regularly**.

Liquid stain

Use soapy water.

Dab lightly (never rub) with a soft cloth, rinse and remove the excess.

Solid or semi-solid stain

Carefully remove the excess solid or pasty material **immediately** with a spatula (working from the edges to the centre to avoid spreading the stain).

In the case of a liquid stain, clean as indicated.

Special instructions for sweets or chewing gum

Put an ice cube on the stain to solidify it, then proceed as for a solid stain.



For further recommendations for maintaining the interior, and/or for any unsatisfactory results, please see an authorised dealer.

INTERIOR TRIM MAINTENANCE

Removal/replacing removable equipment originally fitted in the vehicle

If you need to remove equipment in order to clean the passenger compartment (for example, mats), always ensure that they are correctly refitted and are the right way around. (The driver's mat should be fitted on the driver's side, etc.) and fit them with the components supplied with the equipment (for example, the driver mat should always be fixed using the pre-fitted mounting components).

With the vehicle stationary, ensure that nothing will impede driving (anything obstructing the pedals, heel wedged by the mat, etc.).

Do not do the following

Position objects such as deodorants, scents etc. near air vents as this could damage your dashboard trim.



Use high-pressure cleaning equipment or sprays inside the passenger compartment:

without careful use, this equipment could impair the correct functioning of the electrical or electronic com-

ponents in the vehicle, or have other detrimental effects.

PUNCTURE, EMERGENCY SPARE WHEEL

Spare Wheel

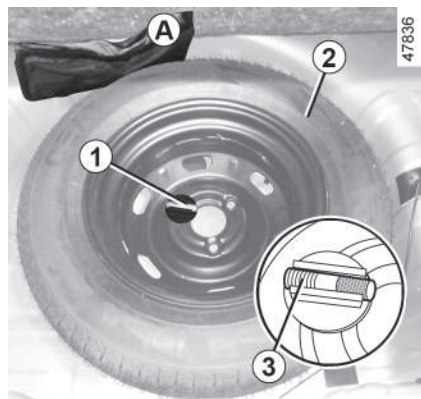

This is located in the luggage compartment.

To access it :

- Open the boot.
- depending on the vehicle, remove the carpet.
- Unscrew the sparewheel lock **1**.
- remove emergency spare wheel **2**.
- Stud **3**.
- Jack pouch **A**.

To store the wheel in the storage location :

Repeat the steps in the reverse order to fit back the spare wheel in the same location.



If spare wheel is stored for long, get it checked by Dealer to ensure that it is safe to use.

- Never fit more than one emergency spare wheel to the same vehicle.
- Replace the emergency spare wheel as soon as possible with the original one.



Note : ensure that the emergency spare wheel or punctured wheel are correctly positioned. Check that the boot carpet is correctly positioned in its bump stops to prevent it from being damaged.



If the vehicle is parked on the hard shoulder, you must warn other road users of your vehicle's presence with a warning triangle or with other devices as per the legislation applying to the country you are in.

PUNCTURE, EMERGENCY SPARE WHEEL



If the emergency spare wheel has been stored for several years, have it checked by your

Dealer to ensure that it is safe to use.

Vehicle fitted with an emergency spare wheel that differs from the other wheels :

- Never fit more than one emergency spare wheel to the same vehicle.
- The punctured wheel is wider than the emergency spare wheel, so the height of the vehicle ground clearance is reduced.
- Replace the emergency spare wheel as soon as possible with a wheel identical to the original one.
- When this is fitted to the vehicle, which must only be a temporary measure, the driving speed must not exceed the speed indicated on the label on the wheel.
- Fitting an emergency spare wheel may alter the way the vehicle usually runs.

Avoid sudden acceleration or deceleration and reduce your speed when cornering.

WHEEL TRIM, TOOLS

Central wheel trim with visible wheel bolts



(example: wheel trim 1)

Depending on the version, the bolts are directly accessible or after removing the wheel cap.

Accessing the tools



Depending on the vehicle, to access the tools:

- open the luggage compartment door;
- depending on the vehicle, lift up the movable floor and/or the luggage compartment mat → 121.



Jack 2

Jack 2 is in a jack pouch and is placed on the left side of the spare wheel in the luggage compartment. To use the jack, take it out from pouch with care.

While keeping it back, fold it up completely and replace it in the pouch.

Wheel wrench 3

This can be used to lock or unlock the wheel bolts and the towing eye 4.

This is placed along with warning triangle. Replace it in the same pouch after use.

Towing eye 4 → 144.

WHEEL TRIM, TOOLS



Do not leave the tools unsecured inside the vehicle as they may be projected during braking. After use, check that all the tools are correctly clipped into the tool kit, then position it correctly in its housing to reduce any risk of injury.

If bolts are supplied with the emergency spare wheel, you must use these bolts only for the emergency spare wheel.



For safety reasons, the use of a jack not recommended by the manufacturer is strictly forbidden.

The jack is specific to the vehicle and used to change the wheels.

Under no circumstances should it be used:

- on another vehicle;
- to carry out a repair;
- to access the underside of the vehicle.

Risk of injury.

Risk of damage to the vehicle.

CHANGING A WHEEL

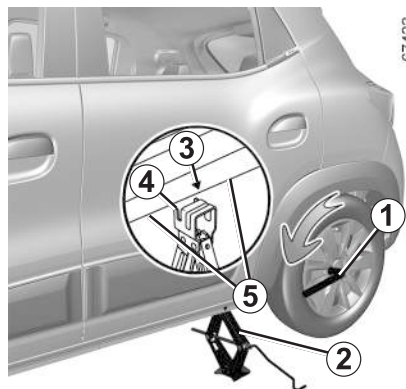

67422

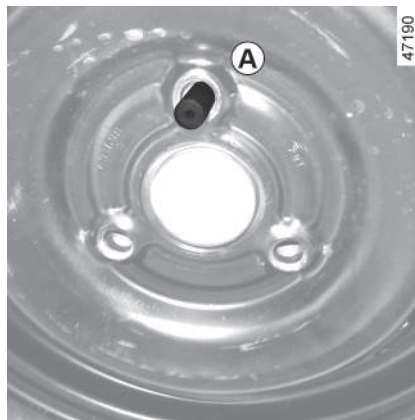

47190



Switch on the hazard warning lights. Keep the vehicle away from traffic and on a level surface where it will not slip. Apply the parking brake and engage a gear (first or reverse, or **P** for automatic transmissions). Ask the passengers to leave the vehicle and to keep away from traffic.

Vehicles equipped with a jack and wheel wrench

Unlock the wheel bolts using the wheel wrench **1**.

Remove completely one of the wheel bolts and screw-in the stud **A** (provided in spare wheel lock screw) in its place, this helps to locate wheel while refitting and retains position when all the wheel bolts are removed.

Position it so as to be able to push from above.

Position the jack **2** horizontally.

The jack head **must** be lined up with the sill closest to the wheel affected and indicated by the arrow **3**.



If the vehicle is parked on the hard shoulder, you must warn other road users of your vehicle's presence with a warning triangle or with other devices as per the legislation applying to the country you are in.

Start cranking the jack by hand, positioning the jack support plate **4** in the slightly indented groove underneath the vehicle, located between the two notches **5** and in the direction of the arrow **3**.

Continue to crank the jack so that the baseplate is correctly positioned (it should be underneath the vehicle and aligned with the jack head).

Turn it a few times to lift the wheel off the ground.

Undo the bolts and take off the wheel.

By aligning one of holes to the stud in the wheel drum/disc.

Fit the emergency spare wheel on the central hub and turn it to locate the mounting holes in the wheel and the hub.

6

CHANGING A WHEEL

Keep the wheel cover (on select variants) and wheel bolts handy, place and hold the wheel cover to align with the stud and fasten the 2 wheel bolts in the remaining locations.

Ensure the wheel is fastened sufficient enough, so that removing stud will not cause the wheel to come out off the drum/disc.

Replace the stud by bolt and put the stud back in spare wheel lock screw cap by gently pressing it in the groove.

6

Tighten the bolts, checking that the wheel is correctly positioned on its hub.

Lower the jack.

With the wheel on the ground, tighten the bolts fully and have the tightness of the bolts checked and the emergency spare wheel pressure checked as soon as possible.



If you have a puncture, replace the wheel as soon as possible.

A tyre which has been punctured should always be inspected (and repaired, where possible) by a specialist.



Do not leave the tools unsecured inside the vehicle as they may be projected during braking.

After use, check that all the tools are correctly clipped into the tool kit, then position it correctly in its housing to reduce any risk of injury.

If bolts are supplied with the emergency spare wheel, you must use these bolts only for the emergency spare wheel.



For safety reasons, the use of a jack not recommended by the manufacturer is strictly

forbidden.

The jack is specific to the vehicle and used to change the wheels.

Under no circumstances should it be used:

- on another vehicle;
- to carry out a repair;
- to access the underside of the vehicle.

Risk of injury.

Risk of damage to the vehicle.

TYRES

The tyres are the only contact between the vehicle and the road, so it is essential to keep them in good condition.

You must make sure that your tyres conform to local road traffic regulations.



For your safety, please respect the speed limit. When they need to be replaced, only tyres of the same make, size, type and profile should be used on a single axle.

They must : either have a load capacity and a speed capacity at least equal to the original tyres, or correspond to those recommended by your authorised dealer.

Failure to heed these instructions could endanger your safety and affect your vehicle's roadworthiness.

Risk of loss of control of the vehicle.

Maintaining the tyres



The tyres must be in good condition and the tread form must have sufficient depth ; tyres approved by our Technical Department have tread wear indicators **1** which are **indicators moulded into the tread at several points.**

When the tread has worn down to the wear warning strips, **these strips will become visible 2 : it is then necessary to replace your tyres because the tread rubber is now only 1.6 mm deep at most, resulting in poor road holding on wet roads.**

An overloaded vehicle, long journeys by motorway, particularly in very hot weather, or continual driving on

poorly surfaced minor roads will lead to more rapid tyre wear and affect safety.



Incidents which occur when driving, such as striking the kerb, may damage the tyres and wheel rims, and could also lead to misalignment of the front or rear axle geometry. In this case, have the condition of these checked by an approved dealer.

Tyre pressures

Adhere to the tyre pressures (including the emergency spare wheel). The tyre pressures should be checked at least once a month and additionally before any long journey (refer to the label affixed to the edge of the driver's door).

TYRES



Incorrect tyre pressures lead to abnormal tyre wear and unusually hot running. These are factors which may seriously affect safety and lead to :

- poor road holding.
- risk of bursting or tread separation.

The pressure depends on the load and the speed of use. Adjust the pressure according to the conditions of use (refer to the label affixed to the edge of the driver's door).

The pressures should be checked cold : ignore higher pressures which may be reached in hot weather or following a high speed journey.

If the tyre pressures cannot be checked when the tyres are **cold, increase the pressures from 0.2 to 0.3 bar (or 3 PSI).**

Never deflate a hot tyre.

Special note

Depending on the vehicle, there may be an adapter which needs to be positioned on the valve before air is added.



Please be aware that a poorly tightened or missing valve cap can make the tyres less airtight and lead to pressure loss. Always use valve caps identical to those fitted originally and tighten them fully.

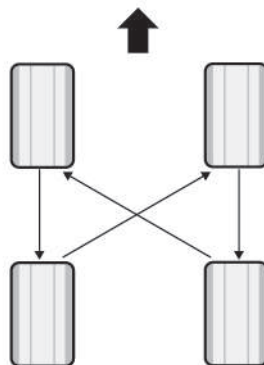

Changing wheels around

Swap the wheels as shown in above picture with every regular intervals 12 months / 10000 Kms (which ever comes earlier).

Swapping needs to be done along with wheel balancing and wheel alignment.

Emergency spare wheel

Refer to the information on "Changing a wheel" in ➔ 125.



Fitting new tyres

For safety reasons, this operation must be carried out by a specialist.

Fitting different tyres may change your vehicle as follows:

- it may mean that your vehicle no longer conforms to current regulations.
- it may change the way it handles when cornering.
- it may cause the steering to be heavy.
- It may affect the use of snow chains.

TYRES



Changing a wheel

As the tyre pressure monitor may take several minutes to correctly determine the positions of the wheels and the pressure values after driving, check the tyre pressures following any operation.



Snow chains may only be fitted to tyres of the same size as those originally fitted to **your vehicle**.

Studded tyres

This type of equipment may only be used for a limited period and as laid down by local legislation. It is necessary to observe the speed specified by current legislation.

These tyres must, at a minimum, be fitted to the two front wheels.



In all cases, we would recommend that you contact an authorised dealer who will be able to advise you on the choice of equipment which is most suitable for your vehicle.

Use in winter

Chains

For safety reasons, fitting snow chains to the rear axle is strictly forbidden.

Chains cannot be fitted to tyres which are larger than those originally fitted to the vehicle.

Snow or Winter tyres

We would recommend that these be fitted to all **four wheels** to ensure that your vehicle retains maximum adhesion.

Warning : These tyres sometimes have a specific direction of rotation and a maximum speed index which may be lower than the maximum speed of your vehicle.

HEADLIGHTS, LIGHTS: CHANGING BULBS

Exterior lighting: changing bulbs

Front headlights: changing the bulbs



Main beam headlights 1 (depending on the vehicle)



Before carrying out any action in the engine compartment, you must switch off the ignition → 57.

67436

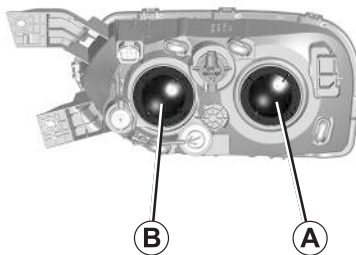

Remove the cover **A**.

67438

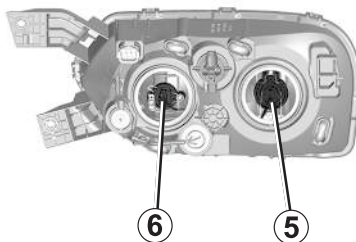

Unclip the connector **5**, remove the assembly from its housing and take out the bulb.

Bulb type : H1.

Dipped beam headlights 2

Remove the cover **B**.

Unclip the connector **6**, remove the assembly from its housing and take out the bulb.

Bulb type: H7.

Before replacing the bulb, make a careful note of its position in its housing. After changing it, check that the replacement bulb is in exactly the same position in the housing. Clip the cover in place.



The headlamps can be replaced. However, we recommend you to have them replaced with an approved dealer, if it proves difficult. To comply with legislation, or as a precaution, you can obtain an emergency kit containing a set of spare bulbs and fuses from an approved dealer.

HEADLIGHTS, LIGHTS: CHANGING BULBS



The engine may be hot during operations in close proximity. In addition, the engine cooling fan may come on at any moment.

Risk of injury.

Direction indicator lights 3

67440

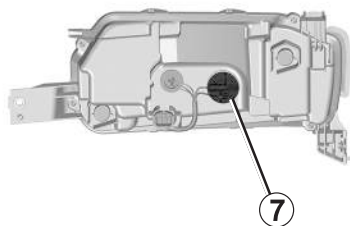

Unlock the socket **7** by rotating in anticlockwise direction.

Remove bulb from the socket.

Bulb type: PY21W.

LED Daytime running lights/side lights 4

Consult an approved dealer.



The bulbs are under pressure and can break when replaced.

Risk of injury.



Any operation on (or modification to) the electrical system must be performed by an approved Dealer since an incorrect connection might damage the electrical equipment (harness, components and in particular the alternator). In addition, your Dealer has all the parts required for fitting these units.



To comply with legislation, or as a precaution, you can obtain an emergency kit containing a set of spare bulbs and fuses from an approved dealer.

Rear lights: changing bulbs

Brake lights, direction indicator lights, reversing lights and Side lights

67431

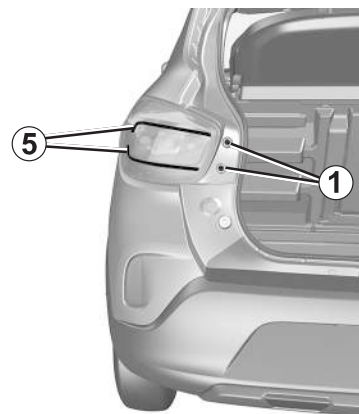

6

Open the luggage compartment and remove the screws **1**.



Do not touch the exhaust.
Risk of burns.

HEADLIGHTS, LIGHTS: CHANGING BULBS

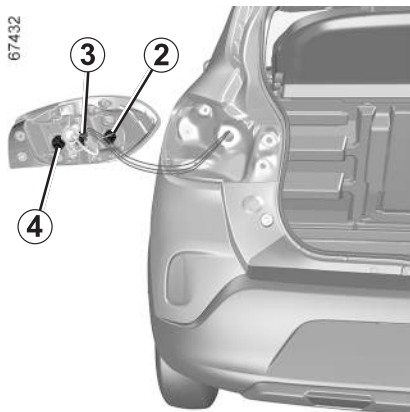

6

Release the lamp assembly by pulling the lamp outwards.

Brake light 2

Bulb type: P21W.

Direction indicator light 3

Bulb type: PY21W.

Reversing light 4

Bulb type: W16W.

LED side light 5

Consult an approved dealer.



To comply with legislation, or as a precaution, you can obtain an emergency kit containing a set of spare bulbs and fuses from an approved dealer.



The bulbs are under pressure and can break when replaced.
Risk of injury.

Refitting

To re-fit, proceed in the reverse order taking care not to damage the wiring, tighten screws **7** first.

Side lights/brake lights, direction indicator lights and reversing lights (depending on the vehicle)

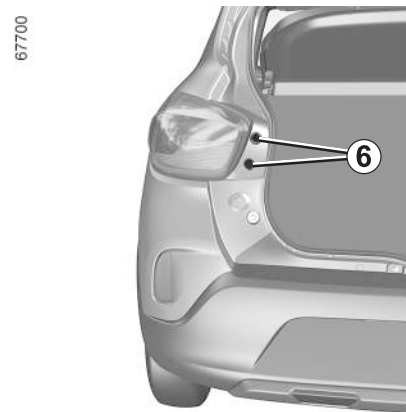

Open the luggage compartment and remove the screws **6**.

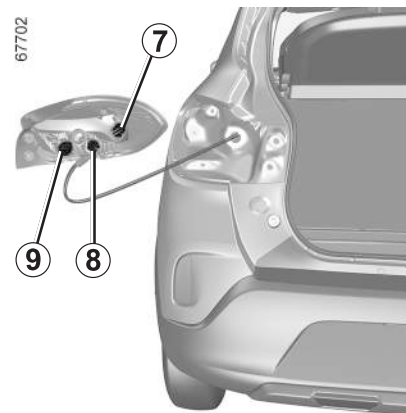

HEADLIGHTS, LIGHTS: CHANGING BULBS

Release the lamp assembly by pulling the lamp outwards.

Brake light/ side light 7

Bulb type: P21/5W.

Direction indicator light 8

Bulb type: PY21W.

Reversing light 9

Bulb type: W16W.



To comply with legislation, or as a precaution, you can obtain an emergency kit containing a set of spare bulbs and fuses from an approved dealer.



The bulbs are under pressure and can break when replaced.
Risk of injury.

Refitting

To re-fit, proceed in the reverse order taking care not to damage the wiring, tighten screws **6** first.

High level brake light



Open the luggage compartment
Slide and remove the high mounted stop lamp cover **A**.

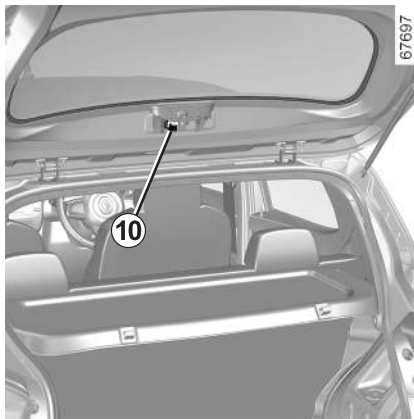

Remove wiring Connector **10**.

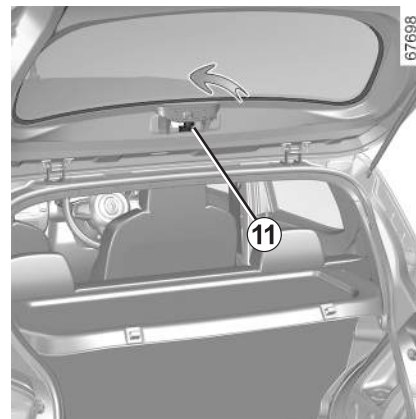

Rotate the bulb Holder **11** in anti-clockwise direction to remove the bulb.

Bulb type: W16W.

Refitting

To refit, proceed in the reverse order, taking care not to damage the wiring. Once the bulb has been replaced, check that it is properly secured.

Number plate lights 12

HEADLIGHTS, LIGHTS: CHANGING BULBS

6

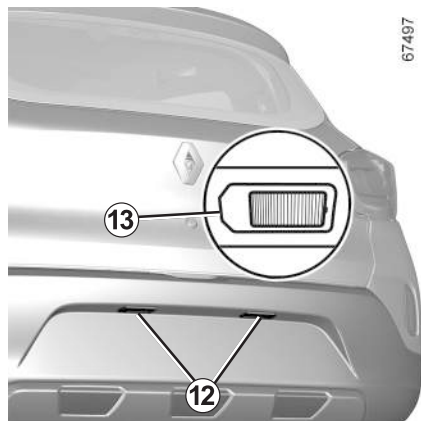

Unclip the light **12** by pressing the tab **13** using a flat-blade screwdriver or similar tool.



Do not touch the exhaust.
Risk of burns.



Unclip the connector **14** and remove the bulb socket.

Rotate the bulb in anti-clock wise direction to remove the bulb from socket.

Bulb type: W5W.

Refitting

To refit, proceed in the reverse order, taking care not to damage the wiring. Once the bulb has been replaced, check that it is properly secured.

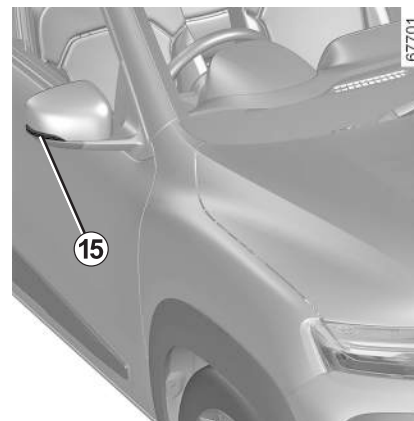

LED Side indicator lights **15**

Consult an approved dealer.

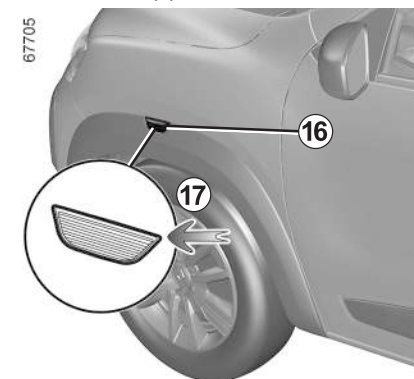

HEADLIGHTS, LIGHTS: CHANGING BULBS

Side indicator lights 16

(depending on the vehicle)

Unclip the indicator light **16** using a flat-blade screwdriver or similar tool positioned at **17** to lever the indicator light towards the outside of the vehicle.

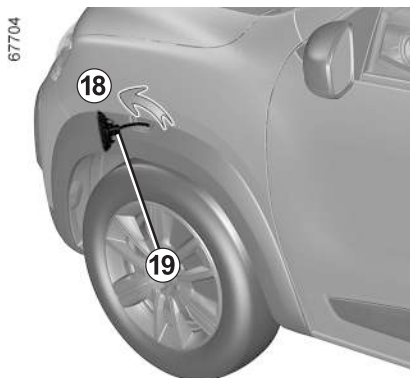

Make a quarter of a turn (movement **18**) on the bulb holder **19** and remove the bulb **20** (movement **21**).

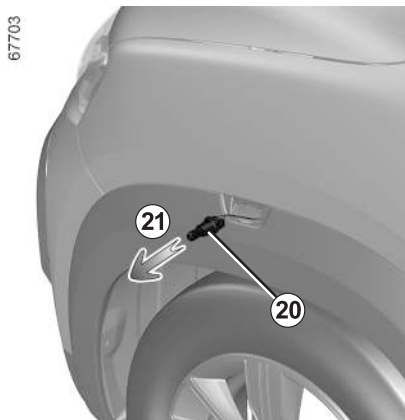

Bulb type: WY5W.

Replace the bulb and refit the indicator light.

Refitting

To refit, proceed in the reverse order, taking care not to damage the wiring. Once the bulb has been replaced, check that it is properly secured.



The bulbs are under pressure and can break when replaced.
Risk of injury.

INTERIOR LIGHTING: CHANGING BULBS

Front courtesy light 1

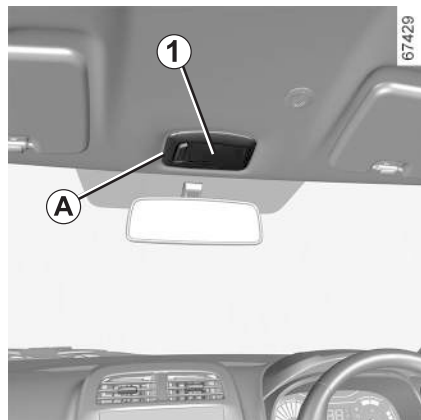

6

- Unclip the light **1** using a tool such as a flat-head screwdriver positioned at **A**;

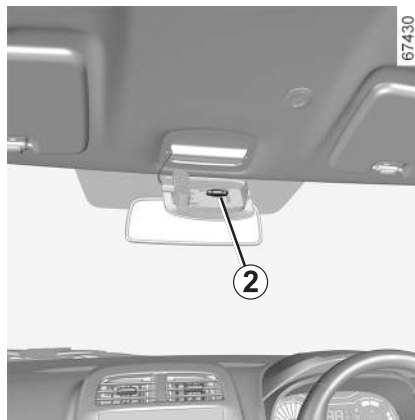

- Remove the bulb from the holder **2**;

Bulb type: Festoon tube 12V

Refitting

- Place the bulb on the holder **2**;
- clip in the courtesy light **1** until you hear the click;
- ensure that the interior lights are properly positioned and locked into place.



The bulbs are under pressure and can break when replaced.
Risk of injury.

RADIO FREQUENCY REMOTE CONTROL

Batteries

Replacing the remote control battery



39533

Insert a minus screw driver into the slit of the Decor shell and twist it to separate the Decor shell from the lower part.



Replace battery **2** according to the direction marked on the cover.

Recommended battery : Contact approved Renault Dealer for replacement of the battery.

Note : It is not advisable to touch the electronic circuit in the key cover when replacing the battery.



The batteries are available from approved Dealers, and their service life approximately two years. Check that there is no dye on the battery : risk of an incorrect electrical contact.



When refitting, ensure that the cover is correctly clipped on and the screw tightened.

26913



Do not throw away your used batteries ; give them to an organisation responsible for collecting and recycling batteries.

FUSES



6

Passenger compartment fuses **A**

If any electrical component does not work, check the condition of the fuses.

Pull the flap A from the lower edge to remove it to access the fuses.



To comply with current legislation, or as a precaution, you can obtain an emergency kit from your approved dealer containing a set of spare bulbs and fuses.

Removing the fuses

Remove the fuse, located at the back of flap **A** from its position. To remove the fuse, slide the fuse. It is not advisable to use the free fuse locations.



The engine may be hot when working in close proximity. In addition, the engine cooling fan may come on at any moment. Risk of injury.



Check the fuse in question and replace it. If a fuse is fitted where the rating is too high, it may cause the electrical circuit to overheat (risk of fire) in the event of an item of equipment using an excessive amount of current.

FUSES

Allocation of fuses

Allocation of fuses in the passenger compartment
(the presence of certain fuses DEPENDS ON THE VEHICLE EQUIPMENT LEVEL)

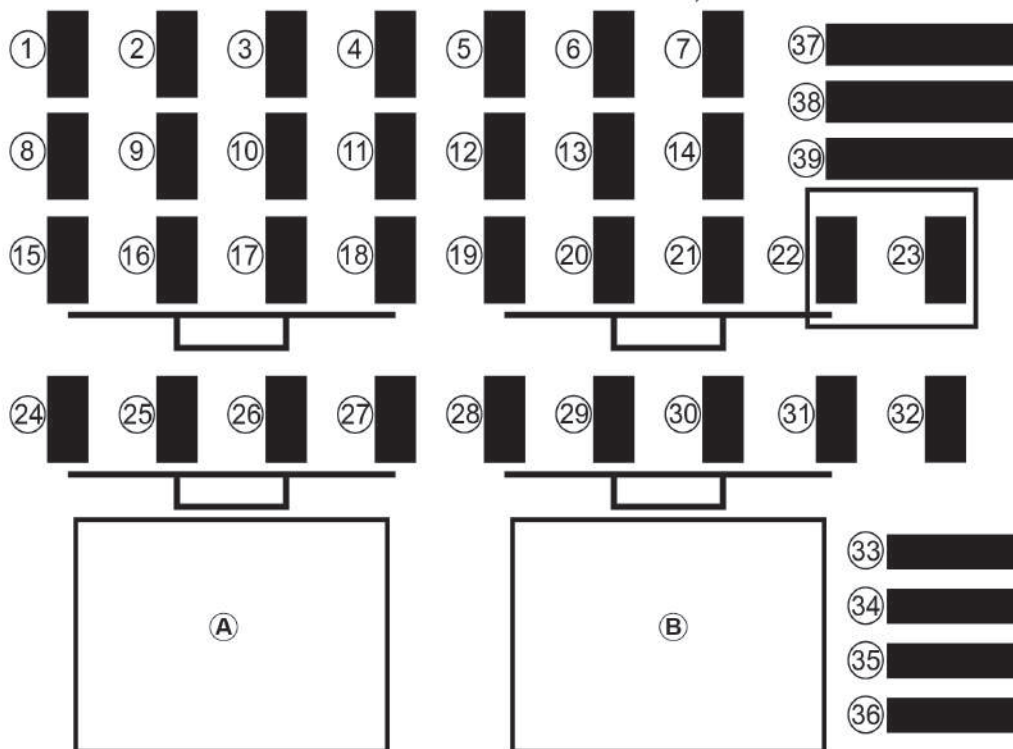

FUSES

6

Number	Allocation
A	Accessories relay
B	Reverse light relay
1	Second row Accessory socket
2	Left-hand main beam headlight
3	Right-hand main beam headlight
4	Left-hand dipped beam headlight
5	Right-hand dipped beam headlight
6	Left-hand side light
7	Cluster /Radio/ Ultra low cost/
8	First Row Accessory Socket
9	Blower Motor
10	Fuel Pump Fuse

Number	Allocation
11	Starter - Manual

	Transmission / Automated Manual transmission
12	Roof Light
13	Cluster
14	Low Beam
15	Radio/Ultra low cost/Diagnostic Socket, Roof Light/ Multimedia accessory socket
16	Empty location
17	Cluster
18	Lighting Switch
19	Electrical Door Locking
20	Electrical Door Locking
21 to 23	Empty location
24	Cluster, Fuel pump, Control Unit-Engine/ Powertrain, Starter

Number	Allocation
25	Stop Light Switch, Radio/ Ultra Low cost
26	Rear Light Switch
27	Windshield Motor

28	Front Dual Window Lift
29	Power Steering
30	Air-Bag
31	Empty location
32	ABS/Stoplight/ Transponder
33	Reverse parking
34	Day light running lamp
35	Rear power window
36	Outside rear view mirror
37 to 39	Empty location

BATTERY

Troubleshooting

To avoid all risk of sparks :

- Ensure that all electrical equipments (courtesy lights, etc.) are switched off before disconnecting or reconnecting the battery.
- when charging, stop the charger before connecting or disconnecting the battery.
- to avoid creating a short circuit between the terminals, do not place metal objects on the battery.
- always wait at least one minute after the engine has been switched off before disconnecting a battery.
- make sure that you reconnect the battery terminals after refitting.

Connecting a battery charger

The battery charger must be compatible with a battery with nominal voltage of 12 volts.

Do not disconnect the battery when the engine is running. **Follow the instructions given by the manufacturer of the battery charger you are using.**



Some batteries may have specific conditions for recharging. Consult your approved dealer. Avoid the risk of sparks, as this could cause a sudden explosion, and always charge the battery in a well-ventilated area.
Risk of serious injury.



Handle the battery with care as it contains sulphuric acid, which must not come into contact with eyes or skin. If it does, wash the affected area with plenty of cold water and consult a doctor, if necessary. Ensure that naked flames, red hot objects and sparks do not come into contact with the battery as there is a risk of explosion.
The engine may be hot when carrying out operations in close proximity. In addition, the engine cooling fan can come on at any moment.
Risk of injury.

Starting the vehicle using the battery from another vehicle

If you have to use the battery from another vehicle to start, obtain suitable jump leads (with a large cross section) from an approved dealer or, if you already have jump leads, ensure that they are in perfect condition.

BATTERY

The two batteries must have an identical nominal voltage of 12 volts.

The battery supplying the current should have a capacity (amp-hours, Ah) which is at least the same as that of the discharged battery.

Ensure that there is no risk of contact between the two vehicles (risk of short circuiting when the positive terminals are connected) and that the discharged battery is properly connected. Switch off your vehicle ignition.

Start the engine of the vehicle supplying the current and run it at an intermediate engine speed.

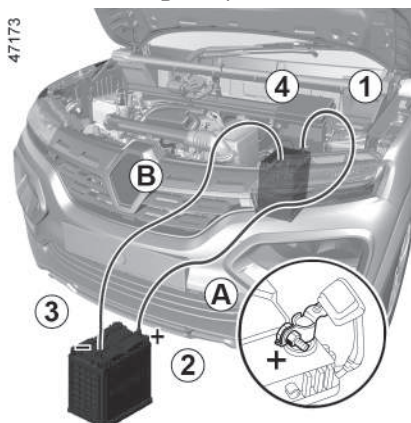

Connect the positive cable (+) **A** to the (+) terminal **1** of the discharged

battery, then to the (+) terminal **2** of the battery supplying the current.

Connect the negative cable (-) **B** to the (-) **3** terminal of the battery supplying the current and then to the (-) **4** terminal of the discharged battery.

Start the engine as normal. As soon as it starts, disconnect cables **A** and **B** in reverse order (**4-3-2-1**).



Check that there is no contact between leads **A** and **B** and that the positive lead **A** is not touching any metal parts on the vehicle supplying the current. Risk of serious injury and/or damage to the vehicle.

WINDSCREEN WIPER - TO LIFT/REPLACE WIPER BLADES

To lift the wiper arm 1

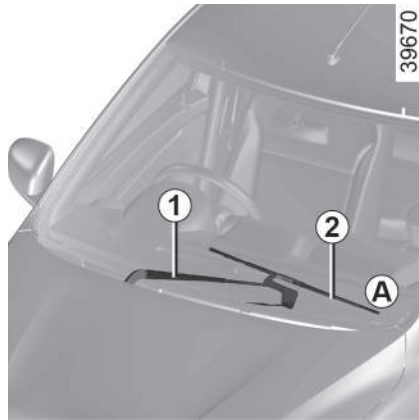

- Switch ON the ignition ;
- Move the wiper stalk from park position **A** (make sure the windscreen is wet with washer fluid while moving the wiper) to intermittent wiping/normal wiping.(Refer to instructions under Windscreen washing/wiping for wiper stalk positions in chapter 1);
- Switch OFF the ignition once the wiper reaches position **B** ;
- Lift the wiper arm **1** ;
- press **3** from inner side of the wiper arm and push the blade down along the direction **C** to remove the wiper blade **2**.

Refitting a wiper blade

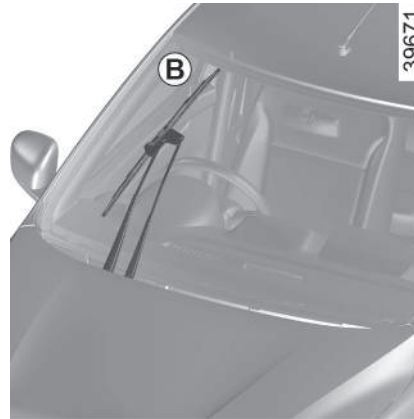

To refit the wiper blade, proceed in reverse order to removal. Make sure that the blade is correctly locked in position.

- i** Do not attempt to remove the dirt from dry windshield with the wipers or you can damage the windshield and wiper blades. Always wet the windshield with washer fluid before operating the wipers.

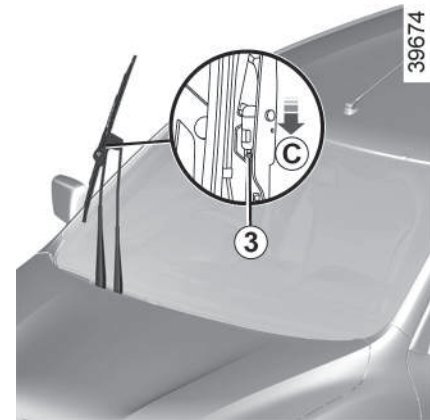

- i** Check condition of the blades. You are responsible for their correct maintenance :

- clean the blades, windscreen and rear screen regularly with soapy water ;
- do not use the wipers when the windscreen is dry ;
- lift them off the windscreen when they have not been used for a long time.

TOWING

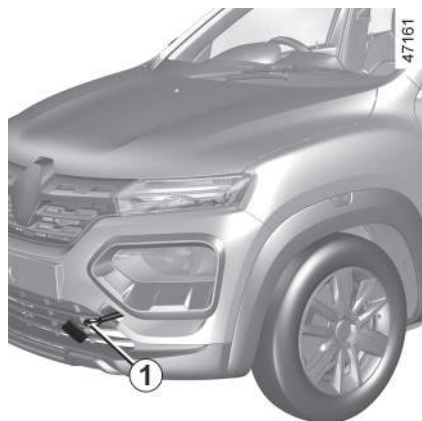

6

The steering wheel must be unlocked and the ignition key must be in ignition ON condition to provide brake lights and hazard warning lights on the towed vehicle. At night the vehicle must have its lights on.

Front towing point 7.

This towing point must only be used for towing : never use it for lifting the vehicle directly or indirectly.



It is prohibited to hang the car to lower arm or Rear Axle. To hang car there is a specific place provided.



Do not leave the tools unsecured inside the vehicle as they may come loose under braking.



Do not remove the key from the ignition when the vehicle is being towed.

When the engine is stopped, steering and braking assistance are not operational.

- Do not leave the tools unsecured inside the vehicle as they may come loose under braking.
- A vehicle must not be towed if it is not fit to be driven.
- Use a rigid towing bar. If a rope or cable is used (where the law allows this), the vehicle being towed must be able to brake.
- A vehicle must not be towed if it is not fit to be driven.

INSTALLATION AND USE OF ACCESSORIES



Electrical and electronic accessories

Before installing this type of accessory (particularly for transmitters/receivers: frequency bandwidth, power level, position of the aerial, etc.), make sure it is compatible with your vehicle. Contact an approved dealer.

Before connecting an accessory to a socket, ensure that it does not exceed the maximum power authorised for the socket → 96, → 92.

Fire hazard.

No work may be carried out on the vehicle's electrical and/or electronic circuits, except by a qualified professional. In fact, an incorrect connection and/or the installation of electrical/electronic accessories not approved by the manufacturer could lead to:

- damage to the electrical and/or electronic equipment;
- damage to the components connected to it;
- the collection and use of vehicle data;
- an invasion of privacy (modification, deletion or unwarranted access to personal data);
- cancellation of the authorisation for entry into service.

Risk of serious accidents.

Risk of invasion of privacy.

If you have electrical equipment fitted in future, make sure that you obtain information on the rating and position of this fuse.

Using the diagnostic socket

The use of electronic accessories on the diagnostic socket may cause serious disturbance to the vehicle's electronic systems. For your safety, we recommend that you only use electronic accessories approved by the manufacturer: consult an approved dealer.

Risk of serious accidents

Fitting aftermarket accessories

If you wish to install accessories on the vehicle: consult an approved dealer. Also, to ensure the correct operation of your vehicle, and to avoid any risk to your safety, we recommend that you use only accessories specifically designed for your vehicle, which are the only accessories for which the manufacturer will provide a warranty.

If you are using an anti-theft device, only attach it to the brake pedal.

INSTALLATION AND USE OF ACCESSORIES

Driver obstruction

On the driver's side, only use mats suitable for the vehicle, attached with the pre-fitted components, and check the fitting regularly. Do not lay one mat on top of another.

There is a risk of wedging the pedals.

OPERATING FAULTS

The following advice will enable you to carry out quick, temporary repairs. For safety reasons you should always contact an approved dealer as soon as possible.

The starter is activated	POSSIBLE CAUSES	WHAT TO DO
Warning lights dim or fail to come on ; the starter does not run.	Battery terminals disconnected, oxidised or incorrectly secured.	Retighten them, reconnect them or clean them if they are oxidised.
	Battery discharged or worn.	Connect another battery to the faulty battery. Refer to the information on "Battery : troubleshooting" in Section 5 or replace the battery if necessary. Do not push the vehicle if the steering column is locked.
The engine is not starting.	Starting conditions are not fulfilled.	Please refer to the information on "Starting, stopping the engine" in Section 2.
The steering column remains locked.	Steering wheel locked.	To unlock, gently move the key and the steering wheel (refer to the information on the "Ignition switch" in Section 2).
Traces of condensation in the lights.	This is not a fault. Traces of condensation are a natural phenomenon caused by variations in temperature. The traces will disappear slowly once the lights are switched on.	
On the road	POSSIBLE CAUSES	WHAT TO DO
Vibrations.	Tyres not inflated to correct pressures, incorrectly balanced or damaged.	Check the tyre pressures ; if this is not the cause, have their condition checked by an approved dealer.
Coolant boiling in the coolant reservoir.	Mechanical fault : cylinder head gasket damaged, faulty coolant pump.	Stop the engine. Contact an approved dealer.

OPERATING FAULTS

On the road	POSSIBLE CAUSES	WHAT TO DO
	Engine cooling fan not working.	Contact an approved dealer.
Smoke under the bonnet.	Short circuit or cooling system leak.	Stop, switch off the ignition, move away from the vehicle and contact an approved dealer.
The oil pressure warning light comes on : on a bend or under braking at idle speed	The engine oil level is too low. Low oil pressure.	Top up the engine oil level (refer to the information on "Engine oil level : topping up/filling" in Section 4). Go to your nearest approved dealer.
The oil pressure warning light takes a long time to go out or remains lit during acceleration.	Loss of oil pressure.	Stop the vehicle : contact an approved dealer.

6

On the road	POSSIBLE CAUSES	WHAT TO DO
The engine overheats. The coolant temperature indicator light comes on.	Engine cooling fan not working.	Stop the vehicle, switch off the engine and contact an approved dealer.
	Coolant leaks.	Stop the vehicle, switch off the engine and check the coolant reservoir : it should contain fluid. If there is no coolant, consult an approved dealer as soon as possible.
The wiper does not work.	Wiper blade stuck.	Free the blades before using the wipers.
	Faulty electrical circuit.	Consult an approved dealer.
The wiper does not stop.	Faulty electrical controls.	Consult an approved dealer.

OPERATING FAULTS

On the road	POSSIBLE CAUSES	WHAT TO DO
Direction indicators flashing more quickly.	Bulb blown.	Replace the bulb.
The direction indicators do not work.	Faulty electrical circuit.	Consult an approved dealer.
The headlights do not switch on or off.	Faulty electrical circuit or control.	Consult an approved dealer.
Abnormal white smoke from the exhaust	Mechanical fault: damaged cylinder head gasket.	Stop the engine. Contact an approved dealer.



Radiator : If there is a significant lack of coolant, remember that it must never be topped up using cold coolant while the engine is very warm. After any procedure on the vehicle which has involved even partial draining of the cooling system, it must be refilled with a new mixture prepared in the correct proportions. Reminder : only products approved by the Technical Department may be used for this purpose.

VEHICLE IDENTIFICATION PLATES

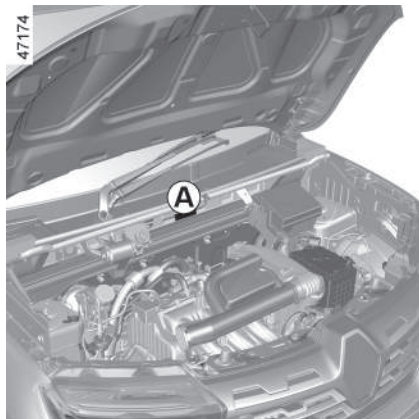

7

The information shown on the vehicle identification plate should be quoted on all correspondence or orders.

Open up the insulator to access the vehicle identification number plate.

Vehicle identification plate A:

Identification number.

ENGINE IDENTIFICATION PLATES

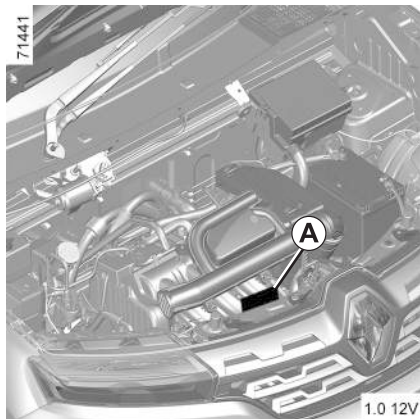

Please quote the information on the engine plate or label **A** in all correspondence or orders.

(Location varies depending on engine)

1. Engine type.
2. Engine suffix.
3. Engine number.

Engine identification plate **A**

Identification number.

33293

A

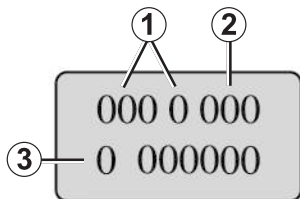

ENGINE SPECIFICATIONS

Versions	1.0 12V
Engine type (see engine plate)	BRI0DE
Cubic capacity (cc)	999
Type of fuel octane rating	Petrol. It is essential to use unleaded petrol with an octane rating 91 and higher.
Spark plugs	Only use spark plugs specified for your vehicle's engine. The type should be marked on a label stuck inside the engine compartment. If it is not, then Contact your approved Dealer for replacement of Spark Plugs. Fitting spark plugs which are not to specification may damage the engine.
Mass of vehicle (Depending on Version)	Kerb weight : 705 Kg- 755 Kg laden condition : 1165 Kg (Max)
Towing weight	NOT PERMITTED
Load on Roof	Not advisable to carry any load on roof

7

ENGINE SPECIFICATIONS

Versions	1.0 12V
Engine type (see engine plate)	BR10DE
Cubic capacity (cc)	999
Fuel types that meet Indian standards and are compatible with the engines of vehicles sold in India (in any other case, contact an Approved Dealer).	<p>E10 Unleaded petrol compliant with standard IS 2796: 2017 containing up to 10% ethanol in volume.</p> <p>E20 Unleaded petrol compliant with standard IS 17021: 2018 containing up to 20% ethanol in volume.</p>

TECHNICAL INFORMATION FOR THE EMERGENCY SERVICES

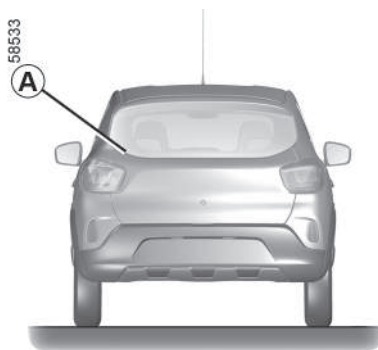
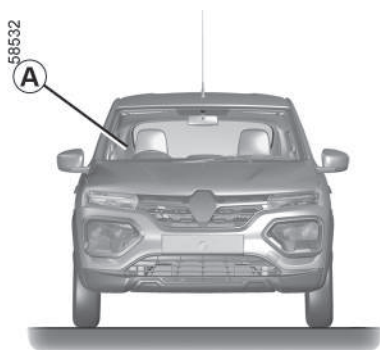

7

The QR Code on the A label allows emergency workers using a tablet or smartphone to immediately access the technical information useful for working on the vehicle in the event of an accident

Ensure that the A label is always visible and present on the windscreen as well as the rear screen

Any modification or damage would prevent access to the information

DIMENSIONS (IN METRES)

(in metres)

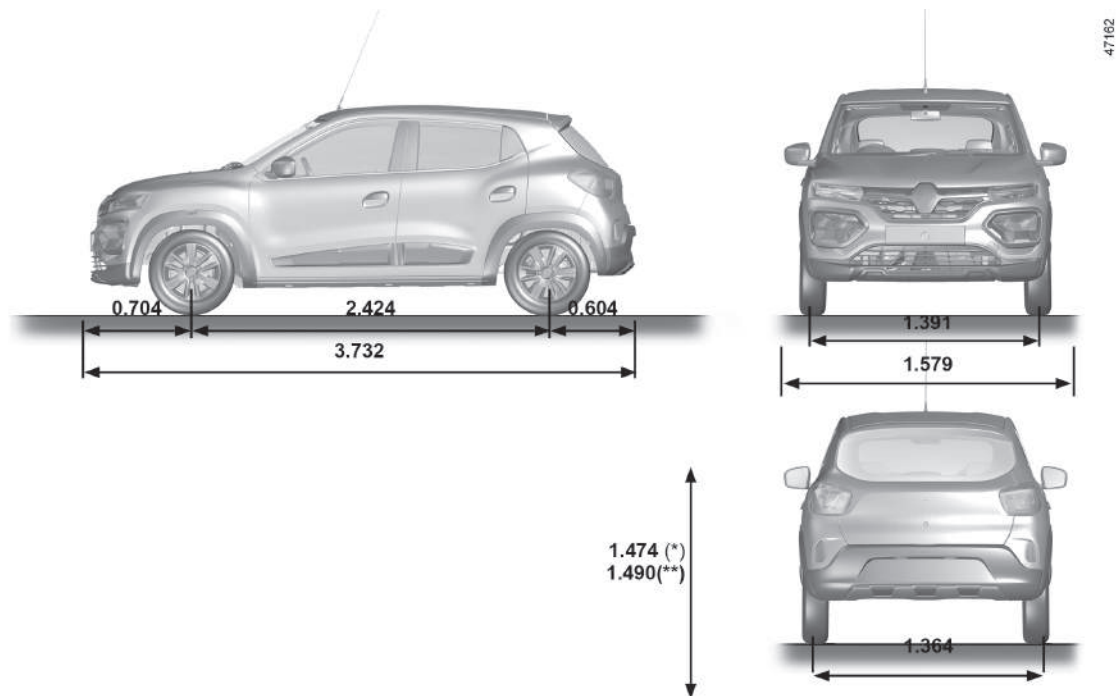

DIMENSIONS (IN METRES)

(*) unladen-without roof style bars

(**) unladen-with roof style bars

7

REPLACEMENT PARTS AND REPAIRS

Original parts are based on strict specifications and are subject to highly specialized tests. Therefore, they are of at least the same level of quality as the parts fitted originally.

If you fit genuine replacement parts always to your vehicle, it will perform well. Furthermore, repairs carried out within manufacturers network using original parts are guaranteed according to the conditions set out on the reverse of repair order.

SERVICE SHEETS

Date : Miles (Km) : Invoice number :		Comments/miscellaneous
Type of operation : Service <input type="checkbox"/> <input type="checkbox"/>	Stamp	
Anti-corrosion check : OK <input type="checkbox"/> Not OK* <input type="checkbox"/> *See specific page		
Date : Miles (Km) : Invoice number :		Comments/miscellaneous
Type of operation : Service <input type="checkbox"/> <input type="checkbox"/>	Stamp	
Anti-corrosion check : OK <input type="checkbox"/> Not OK* <input type="checkbox"/> *See specific page		
Date : Miles (Km) : Invoice number :		Comments/miscellaneous
Type of operation : Service <input type="checkbox"/> <input type="checkbox"/>	Stamp	
Anti-corrosion check : OK <input type="checkbox"/> Not OK* <input type="checkbox"/>		



SERVICE SHEETS

*See specific page	
--------------------	--

VIN :

Date : Miles (Km) : Invoice number :		Comments/miscellaneous
Type of operation : Service <input type="checkbox"/> <input type="checkbox"/>	Stamp	
Anti-corrosion check : OK <input type="checkbox"/> Not OK* <input type="checkbox"/> *See specific page		
Date : Miles (Km) : Invoice number :		Comments/miscellaneous
Type of operation : Service <input type="checkbox"/> <input type="checkbox"/>	Stamp	
Anti-corrosion check : OK <input type="checkbox"/> Not OK* <input type="checkbox"/> *See specific page		
Date : Miles (Km) : Invoice number :		Comments/miscellaneous
Type of operation : Service <input type="checkbox"/> <input type="checkbox"/>	Stamp	
Anti-corrosion check : OK <input type="checkbox"/> Not OK* <input type="checkbox"/> *See specific page		

SERVICE SHEETS

Anti-corrosion check : OK <input type="checkbox"/> Not OK* <input type="checkbox"/> *See specific page		
---	--	--

VIN :

Date : Miles (Km) : Invoice number :		Comments/miscellaneous
Type of operation : Service <input type="checkbox"/> <input type="checkbox"/>	Stamp	
Anti-corrosion check : OK <input type="checkbox"/> Not OK* <input type="checkbox"/> *See specific page		

7

Date : Miles (Km) : Invoice number :		Comments/miscellaneous
Type of operation : Service <input type="checkbox"/> <input type="checkbox"/>	Stamp	
Anti-corrosion check : OK <input type="checkbox"/> Not OK* <input type="checkbox"/> *See specific page		

Date : Miles (Km) : Invoice number :		Comments/miscellaneous
Type of operation :	Stamp	



SERVICE SHEETS

Service <input type="checkbox"/> <input type="checkbox"/>	
Anti-corrosion check : OK <input type="checkbox"/> Not OK* <input type="checkbox"/> *See specific page	

VIN :







Date : Miles (Km) : Invoice number :		Comments/miscellaneous
Type of operation : Service <input type="checkbox"/> <input type="checkbox"/>	Stamp	
Anti-corrosion check : OK <input type="checkbox"/> Not OK* <input type="checkbox"/> *See specific page		
Date : Miles (Km) : Invoice number :		Comments/miscellaneous
Type of operation : Service <input type="checkbox"/> <input type="checkbox"/>	Stamp	
Anti-corrosion check : OK <input type="checkbox"/> Not OK* <input type="checkbox"/> *See specific page		

SERVICE SHEETS

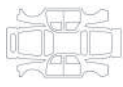



Date : Miles (Km) : Invoice number :		Comments/miscellaneous
Type of operation : Service <input type="checkbox"/> <input type="checkbox"/>	Stamp	
Anti-corrosion check : OK <input type="checkbox"/> Not OK* <input type="checkbox"/> *See specific page		

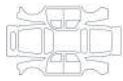
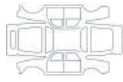
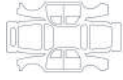

ANTICORROSION CHECK

Corrosion repair operation to be carried out :		Stamp
Date of repair :		
Repair to be carried out :		Stamp
Date of repair :		
Repair to be carried out :		Stamp
Date of repair :		
Corrosion repair operation to be carried out :		Stamp
Date of repair :		
Repair to be carried out :		Stamp
Date of repair :		
Repair to be carried out :		Stamp
Date of repair :		

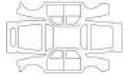
ANTICORROSION CHECK

Corrosion repair operation to be carried out :		Stamp
Date of repair :		
Repair to be carried out :		Stamp
Date of repair :		
Repair to be carried out :		Stamp
Date of repair :		
Corrosion repair operation to be carried out :		Stamp
Date of repair :		
Repair to be carried out :		Stamp
Date of repair :		
Repair to be carried out :		Stamp
Date of repair :		



RENAULT NEW VEHICLE WARRANTY

Terms & Conditions

INDIA

1. Warning:

Your RENAULT vehicle is manufactured to meet the regulations and environmental requirements of the country where such RENAULT vehicle is originally sold. In case you relocate it to another country, it may be very difficult to make modifications to comply with the regulations and environmental requirements of that country and it may be difficult to perform repair service in that country. Please note that a RENAULT vehicle relocated to another country is not covered by the warranty.

2. The RENAULT New Vehicle Warranty

2.1 Duration of Manufacturer's New Vehicle Warranty:

Vehicles in the Renault range, delivered as new from 1 January 2025 to the Customer by the authorised RENAULT DEALER, are warranted against any material, assembly or manufacturing defects by the Manufacturer New Vehicle Warranty for a duration of 3 years or 1,00,000 kilometers (whichever is earlier), as per the delivery date.

2.2 Geographical coverage:

2.2.1 This warranty covers any new vehicle sold within geographical boundaries of INDIA

2.2.2 If the vehicle is to be driven and, more importantly, registered outside the geographical area defined above, such vehicle will not be covered under the current warranty as stated herein.

3. Field of application:

3.1 The Customer is covered for:

free repair (parts, consumables and labour) of any material or assembly defect duly found in the vehicle, at their own request, as well as any repairs on damage caused by this defect to other vehicle parts. It is the authorised RENAULT Dealer's discretion to decide whether it is appropriate to repair or replace the defective part, whilst keeping the Customer informed,

3.2 **24/7 assistance** services as defined in the "Renault Assistance" section under clause 6.

3.3 Original equipment Batteries, Tyres and Audio systems are warranted directly by the respective manufacturers. However, authorised RENAULT dealers shall provide assistance for dealing with the defects to the respective manufacturer.

4. The RENAULT New Vehicle Warranty does not cover and Renault India Private Limited (RIPL) and / or RENAULT authorised workshop shall not be responsible for the following:

RENAULT NEW VEHICLE WARRANTY

4.1 Normal maintenance services other than the three free services, including without limitation, cleaning and polishing, minor adjustments, engine tuning, oil/fluid changes, filters replenishment, fastener retightening, wheel balancing, wheel alignment and tyre rotation etc.

4.2 The indirect and remote consequences of any fault (loss of operation, duration of immobilization, etc.);

4.3 Vehicle components which have undergone conversion work, and/or specification and design changes and the consequences (deterioration, premature wear and tear, alterations, etc.) of the conversion work on other vehicle parts or components, or on its specifications;

4.4 The costs incurred by the Customer for routine maintenance

4.5 Replacement of parts due to normal wear and tear resulting from use of the vehicle or from its mileage including but not limited to clutch, shock absorbers, wiper blades, Windshield, brake drum, brake disk, brake pads, brake shoe, lamp, plugs, belts, linings, bulbs, fuses, parts made of rubber, etc.

4.6 Damage or failure resulting due to the following causes:

4.6.1 Poor vehicle maintenance, in particular if the instructions for the treatment, the frequency of maintenance or care to be applied to the vehicle set out in the Owner's Manual have not been observed;

4.6.2 Due to lack of use / operation of vehicle over prolonged period[s];

4.6.3 Misuse, abuse, negligence, improper driving habits, theft etc. of the vehicle;

4.6.4 Damage from stress, like use of vehicles in races, rallies, etc.,

4.6.5 Use of parts other than Renault Genuine Parts.

4.6.6 Any device and/or accessories not supplied by RIPL.

4.6.7 Modifications, alterations, tampering or improper repair.

4.6.8 Parts used in applications of which they were not designed or not approved by RIPL.

4.6.9 Slight irregularities not recognized as affecting quality or function of the vehicle or parts, such as slight noise or vibrations, or items considered characteristic of the vehicle.

4.7 Damage caused by the following external causes:

4.7.1 Accidents, impacts, scratches, scoring, projection of gravel or solid bodies, hail, acts of vandalism;

4.7.2 Failure to observe the Manufacturer recommendations;

4.7.3 Deposits due to atmospheric pollution, plant-based deposits such as resin, animal-based deposits such as bird droppings, chemical deposits;

RENAULT NEW VEHICLE WARRANTY

4.7.4 Transportation of the vehicle

4.7.5 Using an adulterated/ incorrect fuel;

4.7.6 Fitting accessories not approved by the Manufacturer;

4.7.7 Fitting accessories approved by the Manufacturer, but installed without observing the recommendations defined by the Manufacturer;

4.7.8 Damage due to airborne fallout, industrial fall out, acid rain, hail and wind storms, or other force majeure events like lightning, fire, floods, earthquakes, war, riots, attacks etc.;

4.7.9 Damage caused due to hydro-static lock.

4.7.10 Paint scratches, dents or similar paint or body damage.

4.8 Incidental or consequential damages, including without limitation, loss of time, inconvenience, loss of use of vehicles or commercial loss

5. How does the RENAULT new vehicle warranty work?

5.1 To be eligible for the RENAULT New Vehicle Warranty, the Customer must:

5.1.1 Check that the delivery document does contain the delivery date of the vehicle - their warranty entitlement is dependent on this;

5.1.2 contact any member of the authorised RENAULT workshop – only such members have authorisation for operations of this sort;

5.1.3 show the duly completed Owner's Manual, as proof of entitlement to the warranty and that the maintenance operations recommended by the Manufacturer have been carried out;

5.1.4 have the defect covered by the RENAULT New Vehicle Warranty confirmed as soon as possible, by a Renault authorised workshop in writing. If the vehicle is un-roadworthy, the Customer must contact the nearest RENAULT authorised workshop member or **Renault Assistance**.

5.2 The RENAULT New Vehicle Warranty does not apply, and RIPL and RENAULT authorised dealer members are exempt from all liabilities, if:

5.2.1 The vehicle has been driven under conditions not in accordance with those stated in the Owner's Manual (example: vehicle overloaded or taking part in any type of sports competition, etc.);

5.2.2 The defect observed is due to the Customer having had the vehicle repaired or serviced in a workshop outside the RENAULT authorized network and not observing the manufacturer's recommendations on the subject.

RENAULT NEW VEHICLE WARRANTY

5.3 By way of consideration for the parts supplied by RIPL under the RENAULT New Vehicle Warranty, parts replaced under this warranty legally become the property of RIPL.

5.4 All operations, parts and labour, carried out under the RENAULT New Vehicle Warranty are guaranteed until the new vehicle warranty expires.

5.5 Transferring ownership of the vehicle does not alter the application conditions of the RENAULT New Vehicle Warranty.

6. RENAULT Assistance.

6.1 Renault Assistance:

Renault Assistance is a special assistance program provided by RIPL to the Customers, who have purchased Renault vehicles.

6.2 Eligible parties:

The Customer, or the authorised driver, and all passengers accompanying this driver (limited in number to the number of vehicle seats stated on the certificate of vehicle registration) will be eligible for assistance under the conditions defined below.

6.3 Intervening cause:

The vehicle is immobilized by a breakdown resulting from an unforeseen mechanical, electrical or electronic fault, covered by the Manufacturer's New Vehicle Warranty.

6.4 Assistance service provider

6.4.1 The Assistance services are exclusively provided by **Renault Assistance**.

6.4.2 RIPL and Renault authorized dealers shall not be liable to reimburse the Customer for the expenses/ cost of repair or replacement of any parts or any labour charges or any other expenses incidental or ancillary thereto, if the Customer does not avail these services of Renault Assistance as detailed herein.

6.4.3 Before calling Renault Assistance, the Customer should make a note of the following information so that the breakdown can be dealt with as efficiently as possible:

6.4.3.1 Precise location of the breakdown:

Precise location of the breakdown: road and number, motorway and milepost, visible landmarks, etc.

6.4.3.2 Vehicle identification:

identification number - refer to sticker located on rear left side door quarter glass or stated in the Owner's Manual, vehicle registration number, engine type.

RENAULT NEW VEHICLE WARRANTY

6.4.3.3 Telephone number

on which the Customer can be reached.

6.4.4 On receiving the call from the Customer, and depending on the circumstances, **Renault Assistance** shall arrange and cover the costs of the services defined below:

6.4.4.1 The Customer will not be liable to pay any costs in advance, excluding any costs for connecting journeys and, taking into account current regulations, any towing costs in the event that the vehicle is towed on a motorway or similar highway. In this case, the Customer must advise **Renault Assistance** as soon as they exit the motorway or similar highway.

6.5 WARNING:

Renault Assistance will not be liable for any costs accrued by the Customer without prior written consent from Renault.

6.6 Roadside repair:

Where possible, Renault Assistance shall repair the vehicle at the roadside as soon as possible. If the vehicle cannot be repaired at the roadside and the vehicle must be towed, the driver and their passengers, as defined in the "Eligible parties" section, will be eligible for the following services.

6.6.1 Towing:

The vehicle will be towed to the nearest RENAULT authorized workshop, or failing that, to the nearest garage where the repair can be carried out.

6.6.2 Cab Assistance:

If customer vehicle is recovered to a dealer by Renault Assistance, the driver and passengers will be provided with one free cab ride, only up to 50 Kms., from the breakdown location, to facilitate them to continue their onward journey. Cost of travel beyond 50 Kms., from the breakdown location, and for any other expenses incurred by the Customer, shall be paid by the Customer and RIPL shall not be responsible or liable for it.

6.7 Renault assistance will be available in India except the following geographical areas, Arunachal Pradesh, Meghalaya, Manipur, Mizoram, Nagaland, Sikkim, Tripura, J&K, Andaman & Nicobar Islands and Lakshadweep.

7. The RENAULT Anticorrosion Warranty

7.1 Duration of the Anticorrosion Warranty:

This warranty will apply from the delivery date for a period of 3 years or 1,00,000 kilometers (whichever is earlier), for vehicles in the Renault range.

7.2 Geographical coverage:

RENAULT NEW VEHICLE WARRANTY

The geographical coverage of the Anticorrosion Warranty is identical to that for the Renault New Vehicle Warranty

7.3 Anticorrosion warranty field of application:

7.3.1 In addition to the RENAULT New Vehicle Warranty, RENAULT guarantees the bodywork and sub frame of all RENAULT vehicles in the Schedule I from perforation from the interior, due to steel panel corrosion caused by a manufacturing, material or protective product application defect.

7.3.2 This guarantee covers the repair or replacement of components with perforated steel panel work due to a manufacturing, material or protective product application defect, acknowledged by the Manufacturer.

7.3.3 It is authorized RENAULT workshop's discretion to decide whether it is appropriate to repair or replace these components, and to inform the Customer.

7.4 The Renault Anticorrosion Warranty does not cover:

7.4.1 Any damage which is not covered by the RENAULT New Vehicle Warranty, as defined at the start of this booklet;

7.4.2 Mechanical components which are not an integral part of the bodywork or sub-frame (wheel rims, exhaust system, etc.).

7.5 Anticorrosion Warranty conditions of application

7.5.1 To obtain the Anticorrosion Warranty, the Customer must contact any member of the RENAULT authorized workshop network - only such members have authorization for operations of this sort.

7.5.2 The customer shall show the duly completed delivery documents as proof of their warranty entitlement.

7.5.3 Application of the RENAULT Anticorrosion Warranty is subject to the anticorrosion tests on the bodywork and sub-frame. Customer shall ensure that these tests are conducted at the mileage intervals stated in the Owner's Manual and at least once in every two years. Scheduled maintenance services in the RENAULT authorized workshop network incorporate these tests.

7.5.4 If the Customer requests to have the anticorrosion test conducted independently of the scheduled maintenance service, the same will be carried out at extra cost to the Customer.

7.5.5 During these tests the Customer shall make sure that the professional carrying out the operation correctly completes the bodywork and sub frame test coupon, in order to validate the continuation of the Anticorrosion Warranty.

7.5.6 Repairs on any deterioration must be made as soon as possible.

7.5.7 The application of the RENAULT Anticorrosion Warranty is also subject to bodywork and subframe repairs being carried out in accordance with RENAULT recommendations.

RENAULT NEW VEHICLE WARRANTY

7.5.8 The repair or replacement of components under the conditions described in the “field of application” (Paragraph 7.3), shall take into account the general condition of the vehicle with regard to its age, mileage and maintenance level.

7.5.9 Parts replaced under the Anticorrosion Warranty legally become the property of RENAULT.

7.5.10 Repairs and components fitted under the Anticorrosion Warranty are guaranteed until the end of the term of the original Anticorrosion Warranty.

7.5.11 Transferring ownership of the vehicle does not alter the application conditions of the Anticorrosion Warranty.

8. The RENAULT Paintwork warranty:

8.1 Duration of the Paintwork Warranty:

RENAULT guarantees the bodywork paintwork and painted parts paintwork (door mirrors, bumpers) for 3 years or 1,00,000 kilometers (whichever is earlier) from the delivery date of the new vehicle, for vehicles in the RENAULT range.

8.2 Geographical coverage:

The geographical coverage of the Paintwork Warranty is identical to that for the RENAULT New Vehicle Warranty.

8.3 Paintwork Warranty field of application:

8.3.1 This warranty covers the free repair or replacement of components with paintwork defects (deterioration of lacquer or finishing varnish, due to any material, manufacturing or application defect) acknowledged by the Manufacturer, with the RENAULT authorized workshop carrying out the operation, keeping the Customer informed.

8.3.2 This repair shall take into account the general condition of the vehicle with regard to its age, mileage and maintenance level.

8.4 The RENAULT Paintwork Warranty does not cover:

8.4.1 any damage which is not covered by The RENAULT New Vehicle Warranty, as defined at the start of this booklet;

8.4.2 damage due to force majeure events: lightning, fire, floods, earthquakes, war, riots and attacks;

8.4.3 Mechanical components which are not an integral part of the bodywork or sub-frame (wheel rims, exhaust system, etc.).

8.4.4 Damage due to action of road elements (sand, gravel, dust or road debris) which results in stone chipping of paint or glass.

8.5 Paintwork Warranty conditions of application

8.5.1 To obtain the Paintwork Warranty, the Customer must contact any member of the RENAULT authorized network - only such members have authorization for operations of this sort.

RENAULT NEW VEHICLE WARRANTY

8.5.2 The customer shall show the duly completed delivery documents as proof of their warranty entitlement.

8.5.3 By way of consideration for the parts supplied by RENAULT under the Paintwork Warranty, parts replaced under this warranty legally become the property of RENAULT.

8.5.4 Repairs and components fitted under the Paintwork Warranty are guaranteed until the end of the term of the original Paintwork Warranty.

8.5.5 Transferring ownership of the vehicle does not alter the application conditions of the Paintwork Warranty.

8.6 This warranty is the entire warranty given by RIPL and no dealer or its or his agent or employee is authorized to extend or enlarge this warranty and no dealer or its or his agent or employee is authorized to make any oral warranty on RIPL's behalf.

8.7 RIPL reserves the right to make any change in design or make any improvement on the vehicle at any time without any obligation to make the same change on vehicles previously sold.

8.8 Warranty service shall be provided only by RIPL's authorized dealers and Dealer Service Branch.

8.9 RIPL's decision is final and binding on the Owner of the vehicle in all warranty matters. RIPL reserves the right for the final decision on all warranty matters.

9. All disputes arising out of this Warranty will be subject to the jurisdiction of Courts in Chennai only.

EXTENDED WARRANTY

Renault offers "Renault Secure" Integrated Extended Warranty and Roadside Assistance Program on select models, in addition to the new vehicle warranty. Kindly Contact 1800 315 44 44 (Toll Free number) or your nearest Renault Dealer for more details.

Check for options and prices at <https://www.renault.co.in/renault-services/renault-secure.html>

MAINTENANCE APPENDIX

INFORMATION ON THE MAINTENANCE PROGRAMME

The maintenance program includes the RENAULT service and additional operations. To maintain the original quality of your RENAULT in terms of safety, comfort and performance, you must observe the maintenance program for your vehicle.

RENAULT SERVICE

The RENAULT service applies to all RENAULT vehicles and always includes oil change, oil filter replacement, checks, top-ups and a check of your vehicle's electronic system. The RENAULT service is carried out at the service intervals specified in the maintenance program for your vehicle.

In addition to the service/oil change intervals set by RENAULT, the oil level should still be checked regularly. Your RENAULT dealer is at your disposal to carry out this operation and check other levels, safety parts and for any wear.

ADDITIONAL OPERATIONS:

The additional operations are customized to your vehicle: specific parts or fluids (in addition to the RENAULT service) will need to be replaced in accordance with the service intervals specified in the maintenance program for your vehicle. RENAULT reserves the right to modify its maintenance program at any time during the vehicle's life, within the framework of its vehicle development policy.

CERTAIN CONDITIONS OF USE:

RENAULT recommends that the frequency for replacing specific parts and fluids affected by certain conditions of use should be adapted accordingly.

Hereunder, the list of certain conditions of use and related new replacement frequency (replacement frequency means "when first of the two terms is reached").

A)

- At least 50% of journeys at an average speed less than 30 km/h or with the engine running at idle speed (mainly urban use, taxis, driving school, door-to-door driving, etc),
- At least 30% of kilometers covered towing a trailer weighting more than 500 kg,
- Driving in a dusty environment (building site, more than 1000 km of trails per year,

Operations	Frequency
Change engine oil, oil filter, air filter, fuel filter, cabin filter, belts and rollers (accessory and timing) ^{(1) (2)}	Halve the kilometer frequency for recommended replacement in normal conditions of use,
For the following certain condition of use:	

MAINTENANCE APPENDIX

At least 50% of journeys with the engine running at idle speed, halve, as well, the time frequency replacement for oil and oil filter.

1. The certain condition of use "driving in a dusty environment" does not modify the replacement frequency for belts (accessories and timing) as recommended replacement in normal condition of use.
2. The damper pulleys for certain engines must be replaced during this operation. For more information, please consult your Renault representative.

B)

- Use of engine oil* (for petrol and diesel engines without particles filter), which don't correspond to RENAULT recommendations, (check maintenance pages),
- Prolonged use (+5000 km / year) in temperatures below -15°C,
- Use of fuels that don't correspond to RENAULT recommendations, (See User Manual booklet).
- **For diesel engines with Particles Filter, the use of an other engine oil than the one recommended by RENAULT may damage the Particles Filter.**

Operations	Frequency
Change engine oil, oil filter	Halve the kilometer frequency for recommended replacement in normal conditions of use,

C) Four wheels drive vehicles (4WD): Prolonged use in rough driving conditions (trails, heavy rains...), in very very humid areas or regular driving in water or mud,

Operations	Frequency
Change rear axle oil (4WD) Oil specification: TRANSELF UNIVERSAL FE 80W90	Every other engine oil change

RADIO FREQUENCY AND LOW FREQUENCY APPROVAL

Any radio frequency or low frequency equipment fitted as standard in the RENAULT range complies with the essential requirements of the R & TTE Directive.

The countries that are covered by or agree to this directive are the countries of the European Union, the French overseas departments and territories, the French Southern and Antarctic lands, the French territorial communities and:

MAINTENANCE APPENDIX

Algeria, Andorra, Azerbaijan, Belarus, Bolivia, Colombia, Costa Rica, Ivory Cost, Cuba, Ecuador, Ethiopia, Georgia, Gautemala, the Republic of Guinea-Bissau, Guyana, Honduras, the Channel Islands, the Cayman islands, the Canary Islands, the Comoros Islands, the Faroe Islands, the United States Virgin Islands, India, Ireland, Liberia, Leichtenstein, Macedonia, Mali, Monaco, Namibia, Nepal, Nicaragua, Niger, Norway, New Zealand, Uganda, Uzbekistan, Panama, Paraguay, Ceuta peninsula, the Czech Republic, Russia, Rwanda, San Marino, El Salvador, Sudan, Switzerland, Tanzania, Thailand, Turkmenistan, Turkey, Ukraine, Vatican City, Vietnam,

SERVICE AND MAINTENANCE

In order to ensure economical and safe vehicle operation and to maintain the value of your vehicle, it is of vital importance that all maintenance work is carried out at the proper intervals as specified. Confirmation of service is recorded in the Owner's Manual. The date and mileage is completed with the stamp and signature of the servicing workshop. Make sure that the Owner's Manual is completed correctly as continuous proof of service is essential.

Maintenance services and record retention are the owner's responsibility. You should retain evidence that proper maintenance has been performed on your vehicle in accordance with the scheduled maintenance services chart.

It is recommended to use engine oil with viscosity grade SAE 15W40.

Service Schedules

Product	Re- place- ment fre- quen- cy (Km)	1 Year	2 Year	3 Year	4 Year	5 Year	6 Year	7 Year	8 Year	9 Year	10 Year	11 Year	12 Year
Engine oil	10,000	R	R	R	R	R	R	R	R	R	R	R	R
Oil filter	10,000	R	R	R	R	R	R	R	R	R	R	R	R
Air filter	10,000	R	R	R	R	R	R	R	R	R	R	R	R
Cabin filter	20,000	I	R	I	R	I	R	I	R	I	R	I	R
Brake fluid	60,000			R			R			R			R
Engine Coolant	80,000			R			R			R			R

SERVICE AND MAINTENANCE

Product	Re- place- ment fre- quen- cy (Km)	1Year	2Year	3Year	4Year	5Year	6Year	7Year	8Year	9Year	10 Year	11Year	12Year
Ac- cesso- ry belts (Man- ual trans- mis- sion)	80,000				R				R				R
Ac- cesso- ry belts (Auto- mated manu- al trans- mis- sion)	30,000	I	I	R	I	I	R	I	I	R	I	I	R
Fuel filter	1,20,000												R
Spark plug	MANDATORY REPLACEMENT AT EVERY 30,000 KMS												

SERVICE CHECKS

THE FOLLOWING CHECKS MUST BE CARRIED OUT DURING EVERY SERVICE	
Sl.No.	
1	Check the wiper blades and screen washer fluid levels
2	Check the condition of the windscreen and door mirrors
3	Check the operation of the instrument panel warning lights
4	Check the exhaust pipe
5	Check the levels, condition and sealing of the hydraulic power-assisted steering circuit (if fitted)
6	Check the levels, condition and sealing of the brake/clutch circuit
7	Check the presence of the wheel valve caps
8	Check the presence of the airbag and engine compartment labels
9	Check the signalling and exterior/interior lighting
10	Check the wear of the brake discs and pads
11	Check the condition and pressure of the tyres and road wheel security
12	Check the levels, condition and sealing of the cooling circuit
13	Check the levels, condition and sealing of the sequential gearbox circuits (if fitted)
14	Anti-corrosion check
15	Check the 12 V battery with the test tool
16	Check the computers with the diagnostic tool
17	Check the condition and sealing of the gaiters/rubber mountings/ball joints/shock absorbers
18	Check and lubricate the bonnet lock
19	Clean the sunroof system (if fitted)

SERVICE CHECKS

THE FOLLOWING CHECKS MUST BE CARRIED OUT DURING EVERY SERVICE	
20	Documentation and positioning of the maintenance label
21	Drain the water from the fuel filter
22	Engine oil change alert reinitialisation

ALPHABETICAL INDEX

A

Accessories socket, 92
Advice on antipollution, 65
Air conditioning, 85, 87
Air vents, 84
Anti-corrosion protection, 116
Antipollution advice, 62, 65
Ashtrays, 92

B

Battery, 114
Battery (remote control), 137
Battery troubleshooting, 141
Bonnet, 106

C

Central door locking, 21
Changing a wheel, 121, 125
Changing gear, 60, 75
Cigar lighter, 92
Cleaning : inside the vehicle, 119
Control instruments, 48

D

Doors, 21
Driving, 58, 62, 75

E

Electrical adjustment of the dipped beam headlights, 51
Electric door locking, 21
Electric windows, 88
Emergency spare wheel, 121, 127
Engine oil, 108
Engine oil capacity, 108
Engine oil grade, 108
Environment, 74

F

Filter, 111
Fittings, 91
Front seat adjustment, 26
Front seats, 26
Front seats adjustment, 26
Fuel advice on fuel economy, 62
Fuel economy, 62
Fuel tank, 56
Fuses, 138

G

Gear lever, 60

H

Handbrake, 60
Hands-free telephone integrated control, 96
Headlight beam adjustment, 51



ALPHABETICAL INDEX

Headlights adjustment, 51
Heating and air conditioning system, 84, 85, 87
Heating system, 84, 85, 87

I

Indicators : instrument panel, 48
Instrument panel, 48
Instrument panel messages, 48
Interior trim maintenance, 119

K

Keys, 20

L

Levels, 111
Lifting the vehicle changing a wheel, 125
Lighting signals, 51
Lights: adjusting the beam height, 51
Lights: adjustment, 51
Lights: exterior, 51

M

Maintenance, 65
Maintenance : bodywork, 116
Maintenance : interior trim, 119
Maintenance : mechanical, 111
Multimedia equipment, 96

N

Navigation, 96
Navigation system, 96

P

Paintwork maintenance, 116
Puncture, 121

R

Radio, 96
Rear seat, 93
Rear view mirrors, 41
Remote control door locking batteries, 137
Remote control door locking unit, 20
Reverse gear selecting, 60, 75

S

Sequential gearbox, 75
Starting, 58
Starting the engine, 58
Storage compartment, 91
Storage compartments, 91

T

Tailgate, 94
Telephone, 96
Tool kit, 123
Trip computer and warning system, 48

ALPHABETICAL INDEX

Tyres, 127

V

Ventilation heating and air conditioning system, 85, 87

W

Warning lights, 48

Washing, 116

Wheel trim, 123

Windows, 88

Windscreen washer, 111

Wiper blades, 143

Wipers, 143

Wipers blades, 143



RENAULT S.A.S. SOCIÉTÉ PAR ACTIONS SIMPLIFIÉE / 122-122 BIS, AVENUE DU GENERAL LECLERC 92100 BOULOGNE-BILLANCOURT R.C.S. NANTERRE 780 129 987 — SIRET 780 129 987 03591 / renaultgroup.com

NU 1410-7 - 99 91 009 24V - 12/2024 - Edition anglaise



999100924V

UF